

**Description:**

Slope construction with benches spaced at regular intervals perpendicular to the slope which intercept and collect sheet flow and direct it to a stable outlet point.

**Application:**

- Unstabilized cut and fill slopes
- Large stockpiles
- Existing unstable slopes

**Installation / Application Criteria:**

- Benches should be formed as slope in constructed and graded to the outlet point
- Stabilized outlet with sediment controls should be in place prior to slope construction

**Limitations:**

- Construction slope design must accommodate benching
- Not appropriate for sandy or rocky soil
- Only effective if suitable outlet provide

**Maintenance:**

- Inspect after major storm events and at least biannually; repair damaged areas
- Remove debris blocking water flow
- Inspect outlet, repair/replace sediment controls and remove sediment build up

**Objectives**

- Housekeeping Practices
- Contain Waste
- Minimize Disturbed Areas
- Stabilize Disturbed Areas
- Protect Slopes/Channels
- Control Site Perimeter
- Control Internal Erosion

**Targeted Pollutants**

**H M L**

- Sediment
- Nutrients
- Heavy Metals
- Toxic Materials
- Oil & Grease
- Floatable Materials
- Bacteria & Viruses
- Other Waste

**Implementation Requirements**

**H M L**

- Capital Costs
- O&M Costs
- Maintenance
- Training
- Staffing
- Administrative

**H=High M=Medium L=Low**



153 North 100 East  
Lehi, UT 84043

# BMP: Brush or Rock Filter

BRF

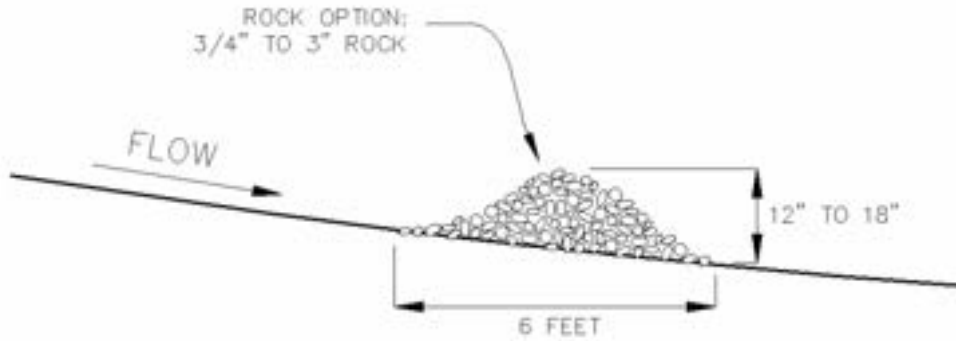

## Objectives

- Housekeeping Practices
- Contain Waste
- Minimize Disturbed Areas
- Stabilize Disturbed Areas
- Protect Slopes/Channels
- Control Site Perimeter
- Control Internal Erosion

## Targeted Pollutants

### H M L

- Sediment
- Nutrients
- Heavy Metals
- Toxic Materials
- Oil & Grease
- Floatable Materials
- Bacteria & Viruses
- Other Waste

## Implementation Requirements

### H M L

- Capital Costs
- O&M Costs
- Maintenance
- Training
- Staffing
- Administrative

H=High M=Medium L=Low



153 North 100 East  
Lehi, UT 84043

## Description:

A rock filter is made of rock 3/4" – 3" in diameter and placed along a level contour. A brush filter is composed of brush (usually obtained during the site cleaning) wrapped in filter cloth and anchored to the toe of the slope. If properly anchored brush or rock filters may be used for sediment trapping and velocity reduction.

## Application:

- As check dams across mildly sloped construction roads
- Below the toe of slopes
- Along the site perimeter
- In areas where sheet flow occurs
- Around temporary spoil areas
- At sediment traps or culvert/pipe outlets

## Installation / Application Criteria:

- If placed where concentrated flows occur, use larger rock and place in a staked, woven wire sheathing
- Install along a level contour
- Leave area behind berm where runoff can pond and sediment can settle
- Drainage areas should not exceed 5 acres

## Limitations:

- Rock berms may be difficult to remove
- Removal problems limit their usefulness in landscaped areas
- Runoff will pond upstream of the filter, possibly causing flooding if sufficient space does not exist

## Maintenance:

- Inspect after each rainfall and at a minimum of once every two weeks
- If berm is damaged, reshape and replace lost/dislodged rock
- Remove sediment when depth reaches 1/3 of berm height or 1 ft

# BMP: Catch Basin Cleaning

CBC

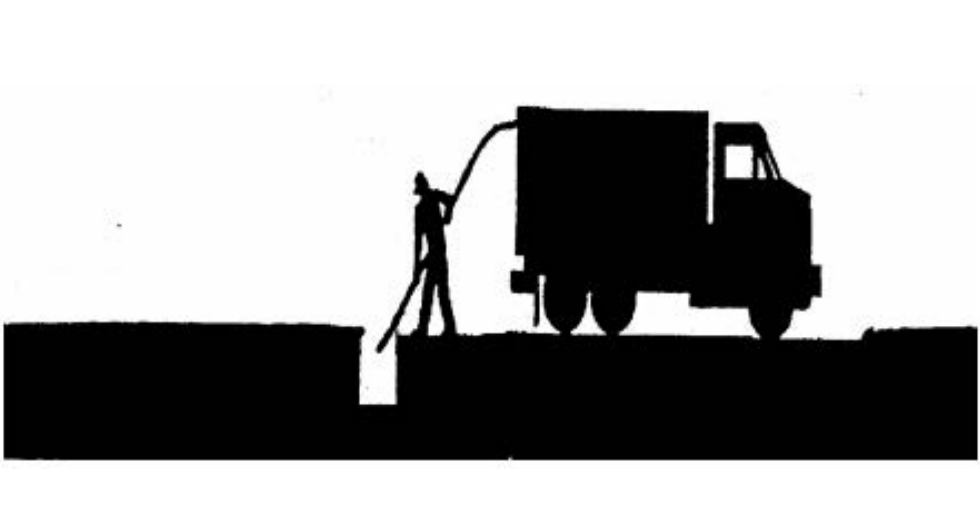

### Description:

Maintain catch basins and stormwater inlets on a regular basis to remove pollutants, reduce high pollutant concentrations during the first flush of storms, prevent clogging of the downstream conveyance system, and restore the catch basin's sediment trapping capacity. A catch basin is distinguished from a stormwater inlet by having at its base a sediment sump designed to catch and retain sediments below the overflow point. This information sheet focuses on the cleaning of accumulated sediments from catch basins.

### Approach:

Regular maintenance of catch basins and inlets is necessary to ensure their proper functioning. Clogged catch basins are not only useless but may act as a source of sediments and pollutants. In general, the keys to effective catch basins are:

- Inspect annually at a minimum
- Prioritize maintenance to clean catch basins and inlets with the highest pollutant loading most frequently
- Clean catch basins in high pollutant load areas just before the wet season to remove sediments and debris accumulated during the summer
- Keep accurate logs of the number of catch basins cleaned
- Record the amount of waste collected

### Limitations:

There are no major limitations to this best management practice.

### Maintenance:

Regular maintenance of public and private catch basins and inlets is necessary to ensure their proper functioning. Clogged catch basins are not only useless but may act as a source of sediments and pollutants. In general, they keys to effective catch basins are:

- Inspect annually at a minimum to ensure systems are properly maintained
- Keep logs of the number of catch basins cleaned
- Record the amount of waste collected

### Objectives

- Housekeeping Practices
- Contain Waste
- Minimize Disturbed Areas
- Stabilize Disturbed Areas
- Protect Slopes/Channels
- Control Site Perimeter
- Control Internal Erosion

### Targeted Pollutants

#### H M L

- Sediment
- Nutrients
- Heavy Metals
- Toxic Materials
- Oil & Grease
- Floatable Materials
- Bacteria & Viruses
- Other Waste

### Implementation Requirements

#### H M L

- Capital Costs
- O&M Costs
- Maintenance
- Training
- Staffing
- Administrative

H=High M=Medium L=Low



153 North 100 East  
Lehi, UT 84043

# BMP: Check Dams

CD

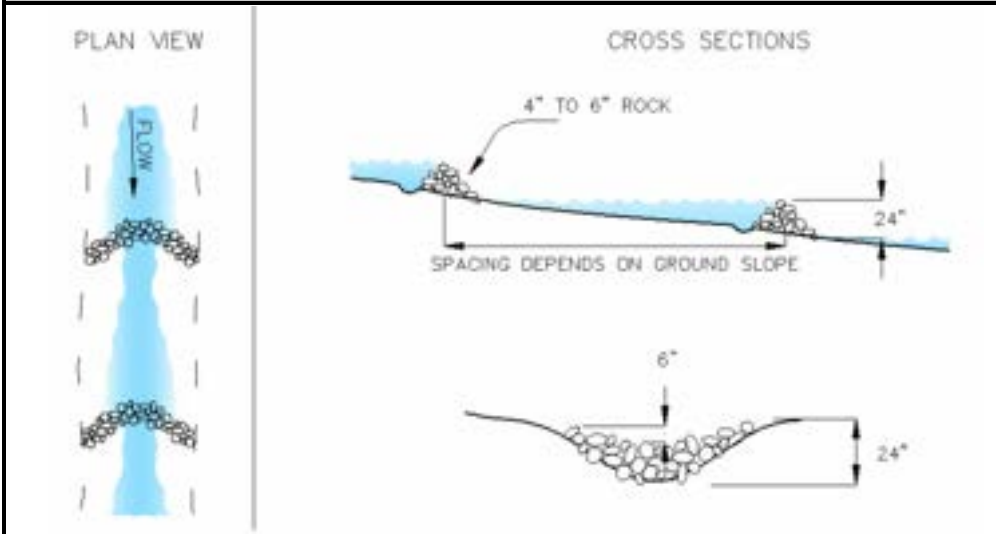

**Description:**

Small, temporary dams constructed across a drainage ditch to reduce velocity of concentrated storm water flows thereby reducing the erosion of the ditch.

**Application:**

- Temporary drainage paths
- Permanent drainage ways not yet stabilized
- Existing drainage paths receiving increased flows due to construction

**Installation / Application Criteria:**

- Prepare location of dam by removing any debris and rough grading any irregularities in channel bottom
- Place rocks by hand or with appropriate machinery; do not dump
- Space dams to make the base of the upstream dam the same elevation as the top of the next lower dam
- Construct dam with center lower to create a weir effect
- Construct 50% side slopes on dams

**Limitations:**

- Maximum recommended drainage area is 10 acres
- Maximum recommended height is 24"
- Do not use in running streams

**Maintenance:**

- Inspect dams daily during prolonged rainfall, after each major rain event, and at a minimum of once every two weeks
- Remove any large debris and repair any damage to dam, channel, or sideslopes
- Remove accumulated sediment when it reaches one half the height of the dam

**Objectives**

- Housekeeping Practices
- Contain Waste
- Minimize Disturbed Areas
- Stabilize Disturbed Areas
- Protect Slopes/Channels
- Control Site Perimeter
- Control Internal Erosion

**Targeted Pollutants**

**H M L**

- Sediment
- Nutrients
- Heavy Metals
- Toxic Materials
- Oil & Grease
- Floatable Materials
- Bacteria & Viruses
- Other Waste

**Implementation Requirements**

**H M L**

- Capital Costs
- O&M Costs
- Maintenance
- Training
- Staffing
- Administrative

H=High M=Medium L=Low



153 North 100 East  
Lehi, UT 84043

# BMP: Contaminated or Erodible Surface Areas

CESA

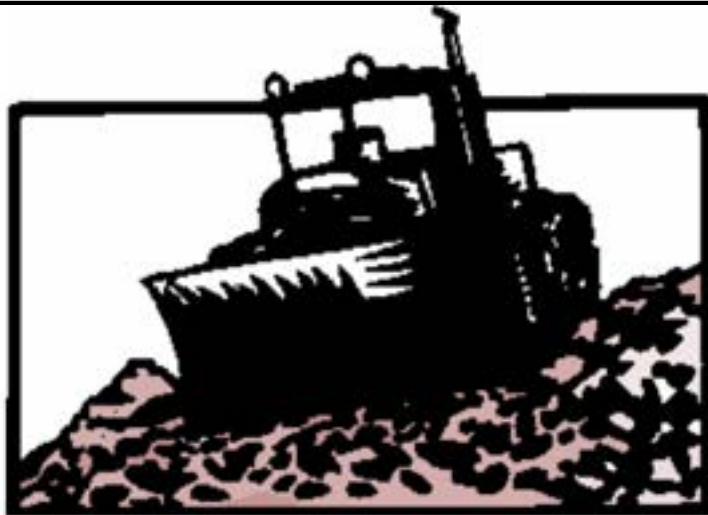

### Description:

Prevent or reduce the discharge of pollutants to storm water from contaminated or erodible surface areas by leaving as much vegetation on-site as possible, minimizing soil exposure time, stabilizing exposed soils, and preventing storm water runoff and runoff.

### Application:

This BMP addresses soils which are not so contaminated as to exceed criteria, but the soil is eroding and carrying pollutants off in the storm water.

### Installation / Application Criteria:

Contaminated or erodible surface areas can be controlled by:

- Preservation of natural vegetation, revegetation, chemical stabilization, removal of contaminated soils, or geosynthetics

### Limitations:

Disadvantages of preserving natural vegetation or re-vegetating include:

- Requires substantial planning to preserve and maintain the existing vegetation
- May not be cost-effective with high land costs
- Lack of rainfall and/or poor soils may limit the success of re-vegetated areas

Disadvantages of chemical stabilization include:

- Creation of impervious surfaces
- May cause harmful effects on water quality
- Is usually more expensive than vegetative cover

### Maintenance:

Maintenance should be minimal, except possibly if irrigation of vegetation is necessary

### Objectives

- Housekeeping Practices
- Contain Waste
- Minimize Disturbed Areas
- Stabilize Disturbed Areas
- Protect Slopes/Channels
- Control Site Perimeter
- Control Internal Erosion

### Targeted Pollutants

#### H M L

- Sediment
- Nutrients
- Heavy Metals
- Toxic Materials
- Oil & Grease
- Floatable Materials
- Bacteria & Viruses
- Other Waste

### Implementation Requirements

#### H M L

- Capital Costs
- O&M Costs
- Maintenance
- Training
- Staffing
- Administrative

H=High M=Medium L=Low



153 North 100 East  
Lehi, UT 84043

# BMP: Construction Road Stabilization

CR

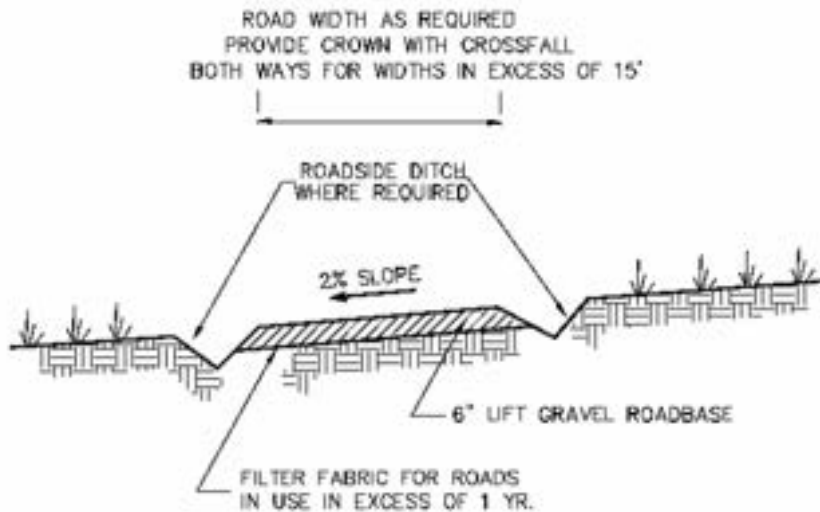

**Description:**

Temporary stabilization of on-site roadway by placement of gravel roadbase

**Application:**

- On-site roadways used daily by construction traffic (may not apply to gravelly type soils)
- Parking or staging areas susceptible to erosion due to traffic use

**Installation / Application Criteria:**

- Grade temporary access roads with 2% cross fall. For two-way width provide crown
- Provide roadside ditch and outlet controls where required
- Place 6 inches of 2-inch to 4-inch crushed rock on driving area

**Limitations:**

- May require removal of gravel roadbase at completion of activities if final cover is not impervious
- May require controls for surface storm water runoff

**Maintenance:**

- Inspect after major rainfall events and at a minimum of once every two weeks
- Place additional gravel as needed and repair any damaged areas
- Maintain any roadside drainage controls

**Objectives**

- Housekeeping Practices
- Contain Waste
- Minimize Disturbed Areas
- Stabilize Disturbed Areas
- Protect Slopes/Channels
- Control Site Perimeter
- Control Internal Erosion

**Targeted Pollutants**

**H M L**

- Sediment
- Nutrients
- Heavy Metals
- Toxic Materials
- Oil & Grease
- Floatable Materials
- Bacteria & Viruses
- Other Waste

**Implementation Requirements**

**H M L**

- Capital Costs
- O&M Costs
- Maintenance
- Training
- Staffing
- Administrative

H=High M=Medium L=Low



153 North 100 East  
Lehi, UT 84043

# BMP: Curb Sedimentation Trap

CST

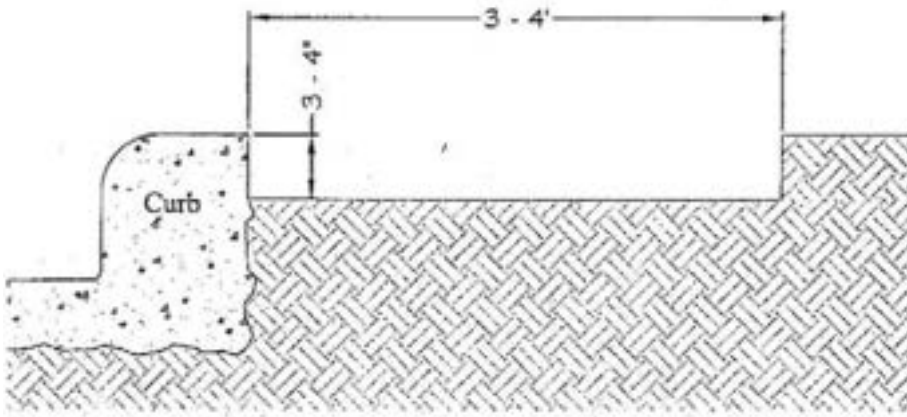

**Description:**

A temporary sediment trap formed by excavation behind the curb.

**Application:**

- Interception of runoff containing sediment from the lot during construction
- Retain sediment on the lot during construction

**Installation / Application Criteria:**

- Excavate soil behind the curb to a depth of 3-4 inches
- Extend excavation 3-4 feet behind the curb to form sediment trap

**Limitations:**

No limitations

**Maintenance:**

- Inspect after each rainfall event and at a minimum of once every two weeks
- Remove accumulated sediment as it reaches 2/3 height of available storage
- May require additional excavation if dirt from construction fills in the trap

**Objectives**

- Housekeeping Practices
- Contain Waste
- Minimize Disturbed Areas
- Stabilize Disturbed Areas
- Protect Slopes/Channels
- Control Site Perimeter
- Control Internal Erosion

**Targeted Pollutants**

**H M L**

- Sediment
- Nutrients
- Heavy Metals
- Toxic Materials
- Oil & Grease
- Floatable Materials
- Bacteria & Viruses
- Other Waste

**Implementation Requirements**

**H M L**

- Capital Costs
- O&M Costs
- Maintenance
- Training
- Staffing
- Administrative

H=High M=Medium L=Low



153 North 100 East  
Lehi, UT 84043

# BMP: Constructed Wetlands

CW

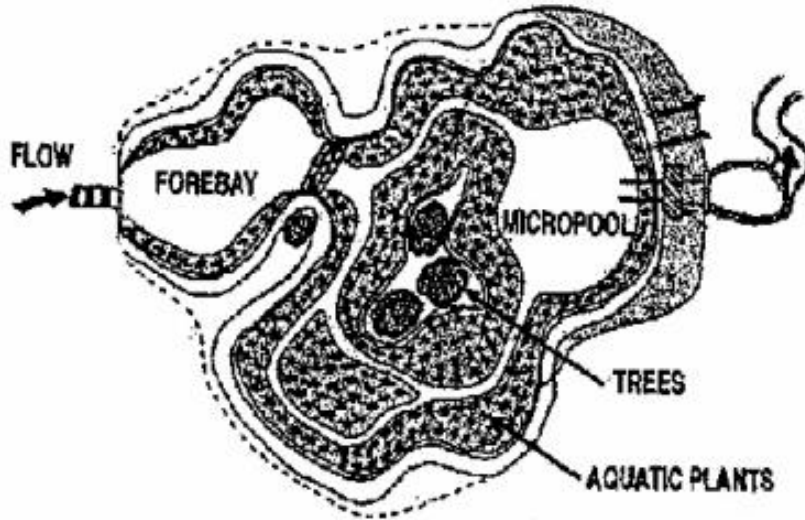

## Objectives

- Housekeeping Practices
- Contain Waste
- Minimize Disturbed Areas
- Stabilize Disturbed Areas
- Protect Slopes/Channels
- Control Site Perimeter
- Control Internal Erosion

## Targeted Pollutants

### H M L

- Sediment
- Nutrients
- Heavy Metals
- Toxic Materials
- Oil & Grease
- Floatable Materials
- Bacteria & Viruses
- Other Waste

## Implementation Requirements

### H M L

- Capital Costs
- O&M Costs
- Maintenance
- Training
- Staffing
- Administrative

H=High M=Medium L=Low



153 North 100 East  
Lehi, UT 84043

### Description:

Constructed wetlands have a significant percentage of the facility covered by wetland vegetation.

### Application:

- Use in areas that need to achieve high level of particulate and some dissolved contaminant removal
- Ideal for large, regional tributary areas
- Multiple benefits of passive recreation and wildlife

### Installation / Application Criteria:

- Suitable soils for wetland vegetation are required
- Surface area equal to at least 1% and preferable 2% of the tributary watershed.
- Involve a qualified wetland ecologist to design and install wetland vegetation
- Establishing wetland vegetation may be difficult

### Limitations:

- Concern for mosquitos
- Cannot be place on steep unstable slopes
- Need base flow to maintain water levels
- Not feasible in densely developed areas
- Nutrient release may occur during winter
- Overgrowth can lead to reduced hydraulic capacity
- Regulatory agencies may limit water quality to constructed wetlands

### Maintenance:

- Remove foreign debris and sediment build-up
- Areas of bank erosion should be repaired
- Remove nuisance species
- Control mosquitos

# BMP: Concrete Waste Management

CWM

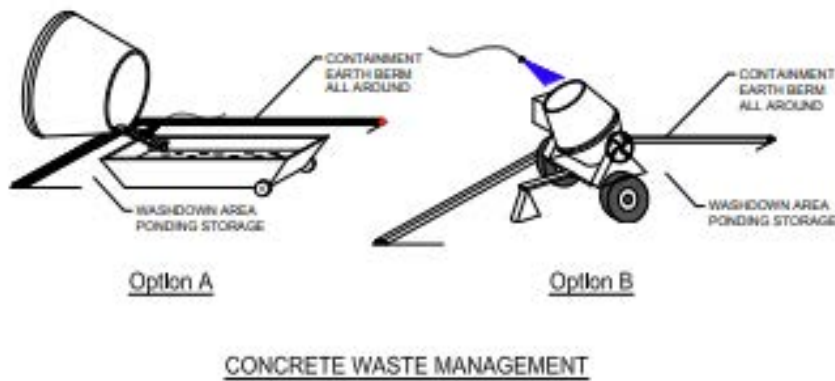

Locate 50' from nearest inlet structure

## Description:

Prevent or reduce the discharge of pollutants to storm water from concrete waste by conducting washout off-site, performing on-site washout in a designated area, and training employees and subcontractors.

## Application:

This technique is applicable to all types of sites

## Installation / Application Criteria:

- Store dry materials under cover, away from drainage areas
- Minimize excess mixing of fresh concrete, mortar or cement on site
- Perform washout of concrete trucks in designated areas located at least 50' from the nearest inlet structure
- Do not wash out concrete trucks into storm drains, open ditches, streets, or streams.
- Concrete, stucco, mortar, plaster, and grout rinse water must be contained in a rigid, leak proof container or leak proof lined pit designed so that no overflows can occur due to inadequate sizing or precipitation
- When washing concrete to remove fine particles and expose the aggregate, avoid creating runoff by draining the water within a bermed or level area (6" tall by 6" wide)
- Train employees and subcontractors in proper concrete waste management

## Maintenance:

- Inspect subcontractors to ensure that concrete wastes are being properly managed
- Concrete washout containers must be emptied or replaced when they reach 75% of capacity

## Objectives

- Housekeeping Practices
- Contain Waste
- Minimize Disturbed Areas
- Stabilize Disturbed Areas
- Protect Slopes/Channels
- Control Site Perimeter
- Control Internal Erosion

## Targeted Pollutants

### H M L

- Sediment
- Nutrients
- Heavy Metals
- Toxic Materials
- Oil & Grease
- Floatable Materials
- Bacteria & Viruses
- Other Waste

## Implementation Requirements

### H M L

- Capital Costs
- O&M Costs
- Maintenance
- Training
- Staffing
- Administrative

H=High M=Medium L=Low



153 North 100 East  
Lehi, UT 84043

**BMP: Dust Controls**

**DC**



**Description:**

Dust control measures are used to stabilize soil from wind erosion and reduce dust from construction activities.

**Application:**

Dust control is useful in any process area, loading and unloading area, material handling area, or transfer area where dust is generated.

**Installation / Application Criteria:**

- Mechanical dust collection systems are designed according to the size of dust particles and the amount of air to be processed. Manufacturer’s recommendations should be followed for installation (as well as the design of the equipment).
- Water used to control dust should be used sparingly to prevent non-storm water discharges
- Mechanical equipment should be operated according to the manufacturers’ recommendations and should be inspected regularly.

**Limitations:**

- More elaborate equipment may be impossible to maintain by plant personnel
- Is labor and equipment intensive and may not be effective for all pollutants

**Maintenance:**

If water sprayers are used, dust-contaminated waters should be collected and taken for treatment. Areas will probably need to be resprayed to keep dust from spreading.

**Objectives**

- Housekeeping Practices
- Contain Waste
- Minimize Disturbed Areas
- Stabilize Disturbed Areas
- Protect Slopes/Channels
- Control Site Perimeter
- Control Internal Erosion

**Targeted Pollutants**

**H M L**

- Sediment
- Nutrients
- Heavy Metals
- Toxic Materials
- Oil & Grease
- Floatable Materials
- Bacteria & Viruses
- Other Waste

**Implementation Requirements**

**H M L**

- Capital Costs
- O&M Costs
- Maintenance
- Training
- Staffing
- Administrative

**H=High M=Medium L=Low**



153 North 100 East  
Lehi, UT 84043

# BMP: Minimizing DCIAs

DCIA

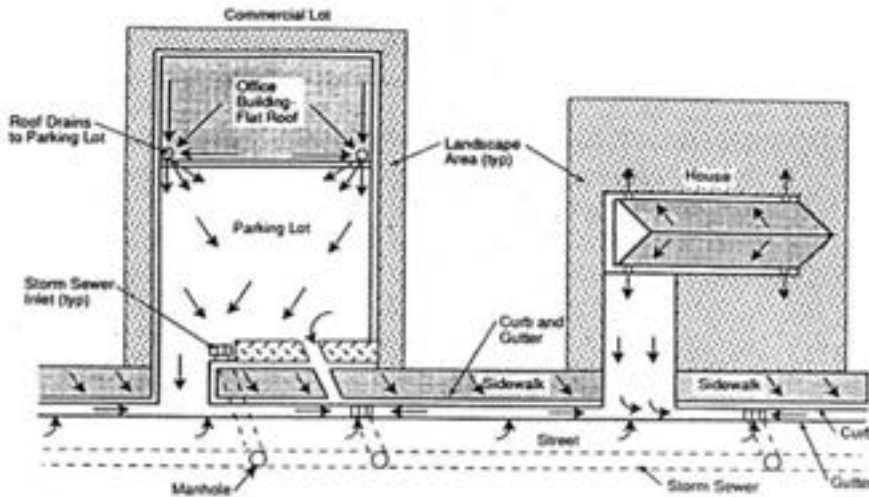

**Description:**

Minimizing directly connected impervious areas (DCIAs) is a structural BMP strategy that requires a basic change in drainage design philosophy. The basic principle is to direct stormwater runoff to landscaped areas, grass buffer strips, and vegetated swales to slow down the rate of runoff, reduce runoff volumes, attenuate peak flows, and encourage filtering and infiltration of stormwater.

**Application:**

Can be made an integral part of drainage planning for any development.

**Installation / Application Criteria:**

- Use on sites with general terrain slopes flatter than 3-4%
- Design the site drainage flowpath to maximize flow over vegetated areas before leaving a site
- Minimize ground slopes to limit erosion and slow down water flow
- Select vegetation that will not only survive, but also enhance water quality

**Limitations:**

- Potential increase in site open space requirements over the traditional development systems
- Introduction of a nonconventional development design strategy
- Infiltration of water near building foundations and parking lots is a concern
- Will likely result in increased maintenance along the swales

**Maintenance:**

- Maintain grass and other vegetation
- Pick up debris
- Conduct ongoing inspections for potential erosion problems and changes in drainage patterns
- Remove sediment buildup and replace damaged grass cover

**Objectives**

- Housekeeping Practices
- Contain Waste
- Minimize Disturbed Areas
- Stabilize Disturbed Areas
- Protect Slopes/Channels
- Control Site Perimeter
- Control Internal Erosion

**Targeted Pollutants**

**H M L**

- Sediment
- Nutrients
- Heavy Metals
- Toxic Materials
- Oil & Grease
- Floatable Materials
- Bacteria & Viruses
- Other Waste

**Implementation Requirements**

**H M L**

- Capital Costs
- O&M Costs
- Maintenance
- Training
- Staffing
- Administrative

H=High M=Medium L=Low



153 North 100 East  
Lehi, UT 84043

# BMP: Diversion Dike

DD

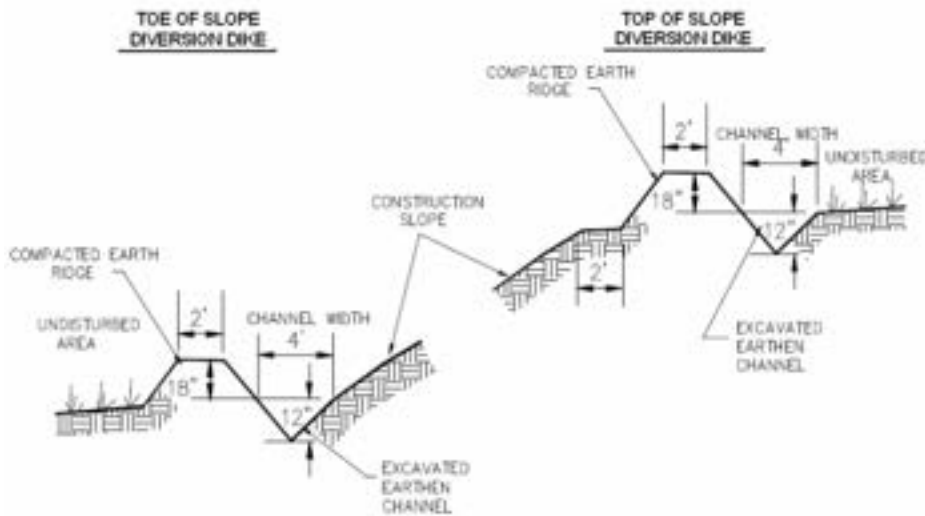

**Description:**

A temporary sediment barrier and storm runoff conveyance consisting of an excavation channel and compacted earth ridge.

**Application:**

- Construct along top of construction slope to intercept upgradient runoff and convey around construction site
- Construct along toe of construction to divert sediment laden runoff
- Construct along midpoint of construction slope to intercept runoff and channel to controlled discharge point
- Construct around base of soil stockpiles to capture sediment
- Construct around perimeter of disturbed areas to capture sediment

**Installation / Application Criteria:**

- Clear and grub area for dike construction
- Excavate channel and place soil on downgradient side
- Shape and machine compact excavated soil to form ridge
- Place erosion protection (riprap, mulch) at outlet
- Stabilize channel and ridge as required with mulch, gravel, or vegetative cover

**Limitations:**

- Recommended maximum drainage area of 5 acres
- Recommended maximum sideslopes of 2:1 (50%)
- Recommend maximum slope of 1% on channel

**Maintenance:**

- Inspect immediately after any rainfall and at least daily during prolonged rainfall
- Look for runoff breaching dike or eroding channel or sideslopes
- Check discharge point for erosion or bypassing of flows
- Repair and stabilize as necessary
- Inspect daily during vehicular activity on slope, check for and repair any traffic damage

**Objectives**

- Housekeeping Practices
- Contain Waste
- Minimize Disturbed Areas
- Stabilize Disturbed Areas
- Protect Slopes/Channels
- Control Site Perimeter
- Control Internal Erosion

**Targeted Pollutants**

**H M L**

- Sediment
- Nutrients
- Heavy Metals
- Toxic Materials
- Oil & Grease
- Floatable Materials
- Bacteria & Viruses
- Other Waste

**Implementation Requirements**

**H M L**

- Capital Costs
- O&M Costs
- Maintenance
- Training
- Staffing
- Administrative

H=High M=Medium L=Low



153 North 100 East  
Lehi, UT 84043

# BMP: Detention Infiltration Device Maintenance

DIDM

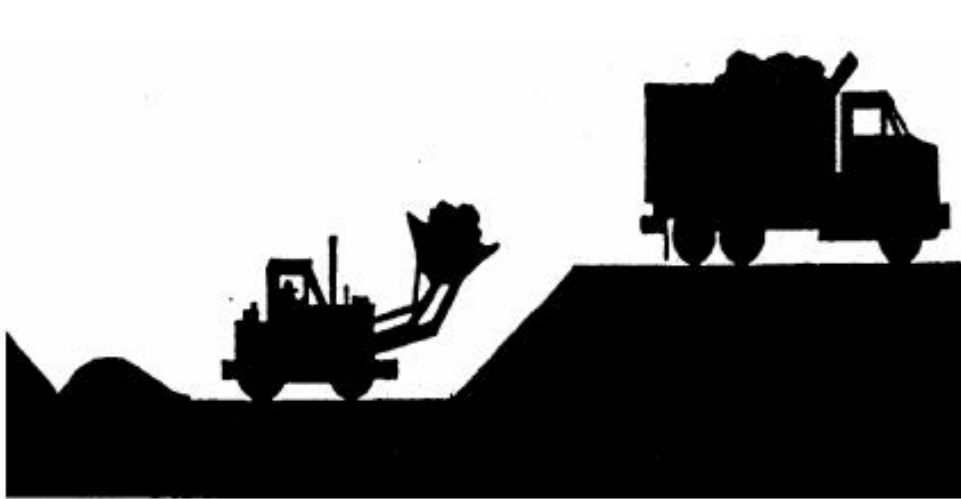

### Description:

Proper maintenance and siltation removal is required on both a routine and corrective basis to promote effective stormwater pollutant removal efficiencies for wet/dry detention pond and infiltrative devices.

### Installation / Application Criteria:

- Remove silt after sufficient accumulation
- Periodically clean accumulated sediment and silt out of pre-treatment inlets
- Infiltration device silt removal should occur when the infiltration rate drops below 1/2 inch per hour
- Removal of accumulated paper, trash, and debris should occur every six months or as needed to prevent clogging of control devices
- Vegetation growth should not be allowed to exceed 18 inches in height
- Mow the slopes periodically and check for clogging, erosion, and tree growth on the embankment
- Corrective maintenance may require more frequent attention (as required)
- Create a public education campaign to explain the function of wet/dry detention ponds/infiltration device and their operation requirements for proper effectiveness
- Encourage the public to report wet/dry detention pond/infiltration devices needing maintenance

### Limitations:

- Wet detention pond dredging can produce slurried waste that often exceeds the requirements of many landfills
- Frequent sediment removal is labor and cost intensive

### Objectives

- Housekeeping Practices
- Contain Waste
- Minimize Disturbed Areas
- Stabilize Disturbed Areas
- Protect Slopes/Channels
- Control Site Perimeter
- Control Internal Erosion

### Targeted Pollutants

#### H M L

- Sediment
- Nutrients
- Heavy Metals
- Toxic Materials
- Oil & Grease
- Floatable Materials
- Bacteria & Viruses
- Other Waste

### Implementation Requirements

#### H M L

- Capital Costs
- O&M Costs
- Maintenance
- Training
- Staffing
- Administrative

H=High M=Medium L=Low



153 North 100 East  
Lehi, UT 84043

# BMP: Earth Berm Barrier

EBB

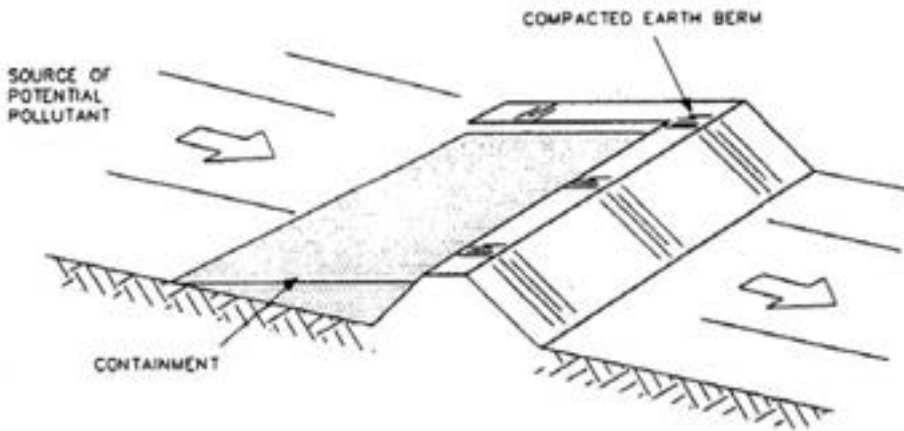

**Description:**

A temporary containment control constructed of compacted soil.

**Application:**

- Construct around waste materials storage area
- Construct around staging and maintenance areas
- Construct around vehicle parking and servicing areas

**Installation / Application Criteria:**

- Construct an earthen berm downhill of the area to be controlled. The berm should surround fueling facilities and maintenance areas on three sides to provide containment
- Berm needs to be sized for application and be compacted by compact equipment

**Limitations:**

- Not effective on steep slopes
- Limits access to controlled area
- Personnel need to quickly respond to spills with remedial actions

**Maintenance:**

- Observe daily for any non-stormwater discharge
- Look for runoff bypassing ends of berms or undercutting berms
- Repair or replace damaged areas of the berm and remove accumulated sediment
- Recompact soil around berm as necessary to prevent piping

**Objectives**

- Housekeeping Practices
- Contain Waste
- Minimize Disturbed Areas
- Stabilize Disturbed Areas
- Protect Slopes/Channels
- Control Site Perimeter
- Control Internal Erosion

**Targeted Pollutants**

**H M L**

- Sediment
- Nutrients
- Heavy Metals
- Toxic Materials
- Oil & Grease
- Floatable Materials
- Bacteria & Viruses
- Other Waste

**Implementation Requirements**

**H M L**

- Capital Costs
- O&M Costs
- Maintenance
- Training
- Staffing
- Administrative

H=High M=Medium L=Low



153 North 100 East  
Lehi, UT 84043

# BMP: Erosion Control Blankets

ECB

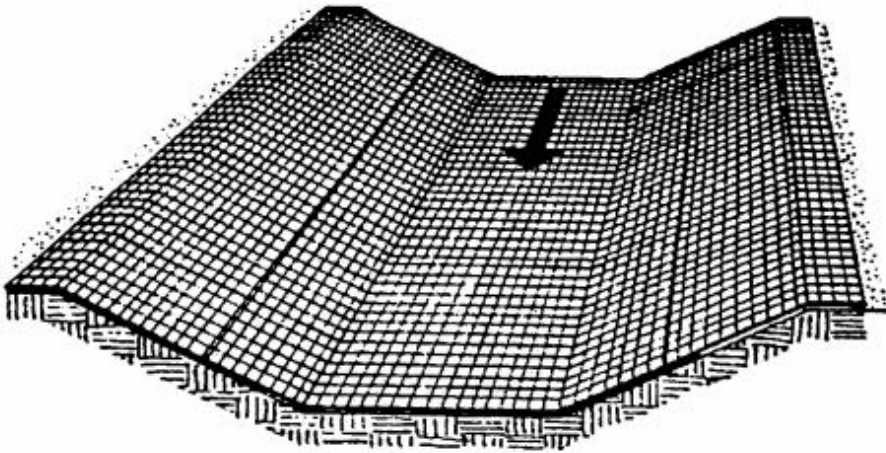

## Objectives

- Housekeeping Practices
- Contain Waste
- Minimize Disturbed Areas
- Stabilize Disturbed Areas
- Protect Slopes/Channels
- Control Site Perimeter
- Control Internal Erosion

## Targeted Pollutants

### H M L

- Sediment
- Nutrients
- Heavy Metals
- Toxic Materials
- Oil & Grease
- Floatable Materials
- Bacteria & Viruses
- Other Waste

## Implementation Requirements

### H M L

- Capital Costs
- O&M Costs
- Maintenance
- Training
- Staffing
- Administrative

H=High M=Medium L=Low



153 North 100 East  
Lehi, UT 84043

## Description:

Erosion control blankets are used on areas of high velocity runoff and/or steep grade, to aid in controlling erosion on critical areas by protecting young vegetation.

## Application:

- Where vegetation is likely to grow too slowly to provide adequate stabilization
- In areas subject to high winds where mulch would not be effective

## Installation / Application Criteria:

- Install erosion control blankets parallel to the direction of the slope
- In ditches, apply in direction of the flow
- Place erosion control blankets loosely on soil – do not stretch
- Ends of blankets should be buried no less than six inches deep
- Staple the edges of the blanket at least every three feet – per manufacturers' specifications

## Limitations:

- Not recommended in areas which are still under construction

## Maintenance:

- Check for erosion and undermining periodically, particularly after rainstorms
- Repair dislocations or failures immediately
- If washouts occur, reinstall after repairing slope damage
- Monitor until permanently stabilized

# BMP: Equipment and Vehicle Wash Down Area

EVWA

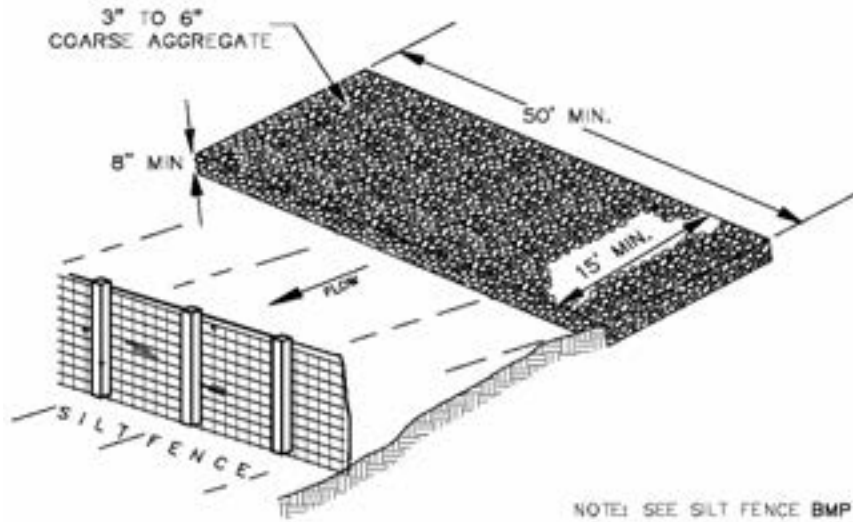

**Description:**

A stabilized pad of crushed stone for general washing of equipment and construction vehicles.

**Application:**

At any site where regular washing of vehicles and equipment will occur. May also be used as a filling point for water trucks to limit erosion caused by overflow or spillage of water.

**Installation / Application Criteria:**

- Clear and grub area and grade to provide maximum slope of 1%
- Compact subgrade and place filter fabric if desired (recommended for wash areas to remain in use for more than 3 months)
- Place coarse aggregate, 1 to 2-1/2 inches in size, to a minimum depth of 8 inches
- Install silt fence downgradient (see silt fence BMP information sheet)

**Limitations:**

Cannot be utilized for washing equipment or vehicles that may cause contamination of runoff such as fertilizer equipment or concrete equipment. Solely used to control sediment in wash water.

**Maintenance:**

- Inspect daily for loss of gravel or sediment buildup
- Inspect adjacent area for sediment deposits and install additional controls as necessary
- Repair area and replace gravel as required to maintain control in good working condition
- Expand stabilized area as required to accommodate activities
- Maintain silt fence as outlined in specific silt fence BMP information sheet

**Objectives**

- Housekeeping Practices
- Contain Waste
- Minimize Disturbed Areas
- Stabilize Disturbed Areas
- Protect Slopes/Channels
- Control Site Perimeter
- Control Internal Erosion

**Targeted Pollutants**

**H M L**

- Sediment
- Nutrients
- Heavy Metals
- Toxic Materials
- Oil & Grease
- Floatable Materials
- Bacteria & Viruses
- Other Waste

**Implementation Requirements**

**H M L**

- Capital Costs
- O&M Costs
- Maintenance
- Training
- Staffing
- Administrative

H=High M=Medium L=Low



153 North 100 East  
Lehi, UT 84043

# BMP: Fiber Rolls

FR

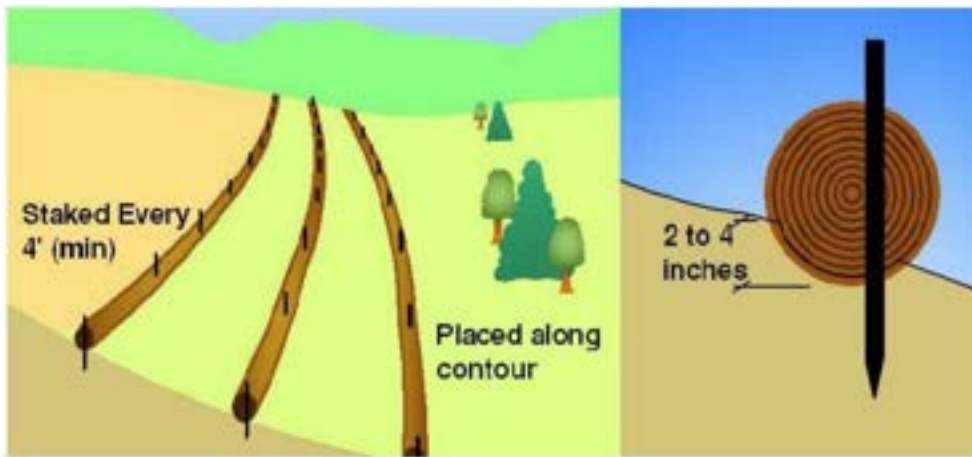

**Description:**

Commercial products can be made from various types of fibers and shavings that are rolled up and used as sediment barriers.

**Application:**

- Good for sites with long slopes, generally flatter than 10:1

**Installation / Application Criteria:**

- Must be trenched into the ground 2 to 4 inches
- Must be staked every 4 feet (maximum)
- Manufacturer's instructions must be followed for installation of product

**Limitations:**

- Not applicable for high velocity flows
- Only use for a time period within the expected lifespan of the product (Check with manufacturer)

**Maintenance:**

- Must be inspected regularly to ensure that runoff does not run under or bypass the fiber rolls
- Sediment buildup must also be checked, and excess sediment must be removed

**Objectives**

- Housekeeping Practices
- Contain Waste
- Minimize Disturbed Areas
- Stabilize Disturbed Areas
- Protect Slopes/Channels
- Control Site Perimeter
- Control Internal Erosion

**Targeted Pollutants**

**H M L**

- Sediment
- Nutrients
- Heavy Metals
- Toxic Materials
- Oil & Grease
- Floatable Materials
- Bacteria & Viruses
- Other Waste

**Implementation Requirements**

**H M L**

- Capital Costs
- O&M Costs
- Maintenance
- Training
- Staffing
- Administrative

H=High M=Medium L=Low



153 North 100 East  
Lehi, UT 84043

# BMP: Filter Strips/Grassed Swales

FS

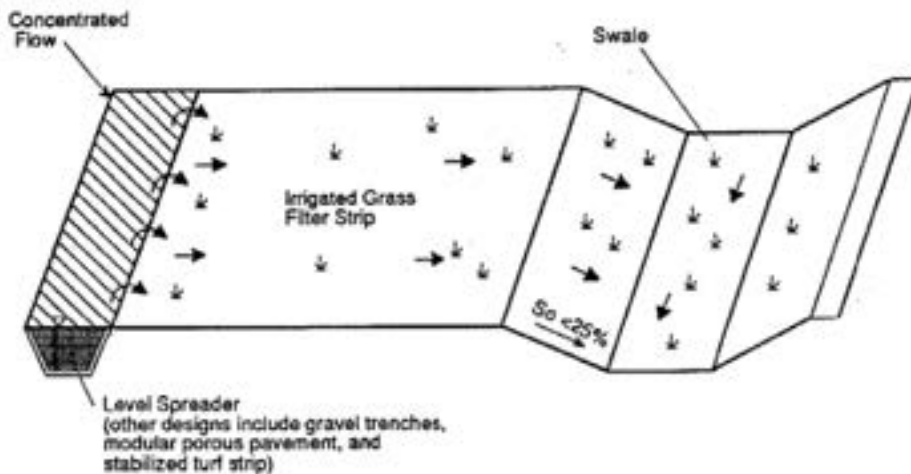

**Description:**

Filter strips are 20-foot-wide strips of natural or planted vegetation around a construction site. They are designed to cause deposition of sediments within the vegetation layer. Grassed swales are designed to treat and attenuate storm water runoff. Storm water is treated through filtering by the vegetation in the channel, filtering through a subsoil matrix, and/or infiltration into the underlying soils.

**Application:**

- Suited for areas where the soils are well drained or moderately well drained
- Areas where the bedrock and the water table are well below the surface
- Swales are well suited for treating highway or residential road runoff because they are linear
- Grassed swales should be used on sites with relatively flat slopes of less than 4 percent.

**Installation / Application Criteria:**

- Make sure the vegetative cover is dense enough to protect the underlying soil while causing sediment to settle
- Filter strip must be approximately 20 feet wide to function well
- The length should be approximately 50 to 75 feet. Where slopes become steeper the length of the strip must be increased
- Swales should have the capacity to pass a 10 year storm safely

**Limitations:**

- Only applicable in areas where vegetation is previously established or where sod is added
- Vegetated filter strips will not function well on steep slopes, in hilly areas, or in highly paved areas
- Sites with slopes of 15 percent or more may not be suitable for filtering storm water flows
- Wet swales may become a nuisance due to mosquito breeding\*

**Maintenance:**

- Check for channels and repair
- Provide rock aprons to aid in slowing flow if necessary
- Maintain vegetation at optimal height and thickness

**Objectives**

- Housekeeping Practices
- Contain Waste
- Minimize Disturbed Areas
- Stabilize Disturbed Areas
- Protect Slopes/Channels
- Control Site Perimeter
- Control Internal Erosion

**Targeted Pollutants**

**H M L**

- Sediment
- Nutrients
- Heavy Metals
- Toxic Materials
- Oil & Grease
- Floatable Materials
- Bacteria & Viruses
- Other Waste

**Implementation Requirements**

**H M L**

- Capital Costs
- O&M Costs
- Maintenance
- Training
- Staffing
- Administrative

H=High M=Medium L=Low



153 North 100 East  
Lehi, UT 84043

# BMP: Grading Practices

GP



Soils exposed from land grading activities are very vulnerable to erosion

**Description:**

Control soil erosion by minimizing the exposure of bare soil to erosive forces. This is done by:

- Limiting the amount of land disturbed at one time in preparation for construction
- Limiting the amount of time between the disturbance of soil and protection or stabilization of disturbed soils, and
- Using grading practices to protect exposed soils susceptible to storm water runoff

Related practices include construction sequencing, preservation of existing vegetation, erosion control practices and sediment control practices.

**Approach:**

- Limit the area of disturbance to those areas requiring grading. This preserves existing vegetation and reduces the vulnerability of soil to erosion
- Based on erosion potential and sediment control measures on the site, establish what areas are to be graded at one time.
- An undisturbed buffer zone containing vegetation at the lowest elevation of a construction site can reduce the transport of sediment off site.
- Initiate soil protection measures during the course of work to minimize the length of time soil is exposed to erosive forces
- Conduct work in stages so that construction or soil stabilization occurs promptly after disturbance of soil
- Establish a schedule governing the stabilization of disturbed slopes, both in terms of passage of time since commencement and completion of disturbance and in terms of planting season
- Leaving the surface of the disturbed soil graded in a roughened condition (not smooth) can reduce the quantity and velocity of storm water runoff
- Prevent storm water runoff from running onto steep slopes from above
- Avoid long, steep cut or fill slopes that allow runoff water of sufficient quantity or velocity to cut into and erode the slope.

**Limitations:**

The specific approach to grading on a particular site depends on the conditions of the site and surrounding land: engineering judgment is required to design the approach best suited for each site.

**Maintenance:**

Practices may need to vary from the approved plan if erosion problems appear when storm water runoff occurs.

**Objectives**

- Housekeeping Practices
- Contain Waste
- Minimize Disturbed Areas
- Stabilize Disturbed Areas
- Protect Slopes/Channels
- Control Site Perimeter
- Control Internal Erosion

**Targeted Pollutants**

**H M L**

- Sediment
- Nutrients
- Heavy Metals
- Toxic Materials
- Oil & Grease
- Floatable Materials
- Bacteria & Viruses
- Other Waste

**Implementation Requirements**

**H M L**

- Capital Costs
- O&M Costs
- Maintenance
- Training
- Staffing
- Administrative

H=High M=Medium L=Low



153 North 100 East  
Lehi, UT 84043

# BMP: Hydromulching

HM



### Description:

A combination of wood fiber mulch, processed grass, or hay or straw mulch and a tacking agent. It is made into a slurry, then applied to bare slopes or other bare areas to provide temporary stabilization.

### Application:

- Small roadside slopes
- Large, relatively flat areas

### Installation / Application Criteria:

- Legume seeds should be pellet inoculated with the appropriate bacteria.
- The seed should not remain in the hydromulcher tank for more than 30 minutes
- Wood fiber may be dyed to aid in uniform application
- Slurry should be uniformly applied until an adequate coverage is achieved
- The applicator should not be directed at one location for a long period of time or erosion will occur

### Limitations:

- Will lose effectiveness after 1 year
- Can only be used on physically stable slopes (at natural angle of repose, or less)

### Maintenance:

- Periodically inspect for damage caused by wind, water, or human disturbance
- Promptly repair damaged areas

### Objectives

- Housekeeping Practices
- Contain Waste
- Minimize Disturbed Areas
- Stabilize Disturbed Areas
- Protect Slopes/Channels
- Control Site Perimeter
- Control Internal Erosion

### Targeted Pollutants

#### H M L

- Sediment
- Nutrients
- Heavy Metals
- Toxic Materials
- Oil & Grease
- Floatable Materials
- Bacteria & Viruses
- Other Waste

### Implementation Requirements

#### H M L

- Capital Costs
- O&M Costs
- Maintenance
- Training
- Staffing
- Administrative

H=High M=Medium L=Low



153 North 100 East  
Lehi, UT 84043

# BMP: Hazardous Waste Materials

HWM



### Description:

Prevent or reduce the discharge of pollutants to stormwater from hazardous waste through proper material use, waste disposal, and training of employees and subcontractors.

### Application:

Many of the chemicals used on-site can be hazardous materials which become hazardous waste upon disposal. These wastes may include:

- Paints and solvents; petroleum products such as oils, fuels, and grease; herbicides and pesticides; acids for cleaning masonry; and concrete curing compounds

In addition, sites with existing structures may contain wastes which must be disposed of in accordance with Federal, State, and local regulations, including:

- Sandblasting grit mixed with lead, cadmium, or chromium-based paints; asbestos; and PCB's

### Installation / Application Criteria:

The following steps will help reduce storm water pollution from hazardous wastes:

- Use all of the product before disposing of the container
- Do not remove the original product label, it contains important safety and disposal information
- Do not over-apply herbicides and pesticides. Prepare only the amount needed. Follow the recommended usage instructions. Apply surface dressings in several smaller applications, as opposed to on large application, to allow time for infiltration and to avoid excess material being carried off-site by runoff. Do not apply these chemicals just before it rains. People applying pesticides must be certified in accordance with Federal and State regulations.

### Limitations:

Hazardous waste that cannot be reused or recycled must be disposed of by a licensed hazardous waste hauler.

### Maintenance:

- Inspect hazardous waste receptacles and area regularly
- Arrange for regular hazardous waste collection

### Objectives

- Housekeeping Practices
- Contain Waste
- Minimize Disturbed Areas
- Stabilize Disturbed Areas
- Protect Slopes/Channels
- Control Site Perimeter
- Control Internal Erosion

### Targeted Pollutants

#### H M L

- Sediment
- Nutrients
- Heavy Metals
- Toxic Materials
- Oil & Grease
- Floatable Materials
- Bacteria & Viruses
- Other Waste

### Implementation Requirements

#### H M L

- Capital Costs
- O&M Costs
- Maintenance
- Training
- Staffing
- Administrative

H=High M=Medium L=Low



153 North 100 East  
Lehi, UT 84043

# BMP: Illegal Dumping Controls

IDC



### Description:

Implement measures to detect, correct, and enforce against illegal dumping of pollutants on streets, into the storm drain system, and into creeks. Substances illegally dumped on streets, into the storm drain system, and into creeks include paints, used oil and other automotive fluids, construction debris, chemicals, fresh concrete, leaves, grass clippings, and pet wastes. All of these wastes can cause storm water and receiving water quality problems as well as clog the storm drain system.

### Approach:

One of the keys to success is increasing the general public's awareness of the problem and to at least identify the incident, if not correct it. There are a number of ways of accomplishing this:

- Train municipal staff from all departments to recognize and report incidents.
- Deputize municipal staff who may come into contact with illegal dumping with the authority to write illegal dumping tickets for offenders caught in the act.
- Educate the public.
- Provide the public with a mechanism for reporting such as a hotline

Establish system for track incidents which will identify:

- Illegal dumping "hot spots"
- Types and quantities (in some cases) of wastes,
- Patterns in time of occurrence (time of day/night, month, or year)
- Mode of dumping (abandoned containers, "midnight dumping" from moving vehicles, direct dumping of materials, accidents/spills)
- Responding parties

A tracking systems also helps manage the program by indicating trends, and identifying who, what, when, and where efforts should be concentrated.

### Limitations:

The elimination of illegal dumping is dependent on the availability, convenience, and cost of alternative means of disposal.

### Objectives

- Housekeeping Practices
- Contain Waste
- Minimize Disturbed Areas
- Stabilize Disturbed Areas
- Protect Slopes/Channels
- Control Site Perimeter
- Control Internal Erosion

### Targeted Pollutants

#### H M L

- Sediment
- Nutrients
- Heavy Metals
- Toxic Materials
- Oil & Grease
- Floatable Materials
- Bacteria & Viruses
- Other Waste

### Implementation Requirements

#### H M L

- Capital Costs
- O&M Costs
- Maintenance
- Training
- Staffing
- Administrative

H=High M=Medium L=Low



153 North 100 East  
Lehi, UT 84043

# BMP: Inlet Protection – Concrete Block

IP

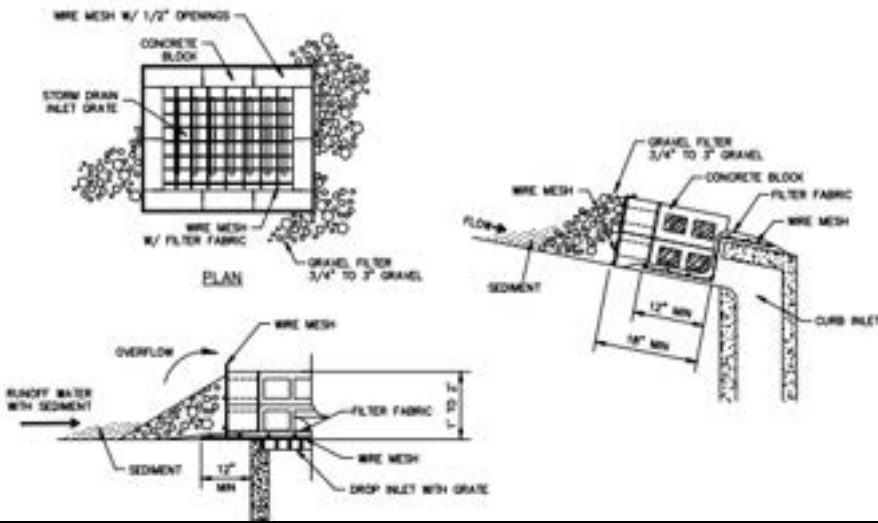

## Objectives

- Housekeeping Practices
- Contain Waste
- Minimize Disturbed Areas
- Stabilize Disturbed Areas
- Protect Slopes/Channels
- Control Site Perimeter
- Control Internal Erosion

## Targeted Pollutants

### H M L

- Sediment
- Nutrients
- Heavy Metals
- Toxic Materials
- Oil & Grease
- Floatable Materials
- Bacteria & Viruses
- Other Waste

## Implementation Requirements

### H M L

- Capital Costs
- O&M Costs
- Maintenance
- Training
- Staffing
- Administrative

H=High M=Medium L=Low



153 North 100 East  
Lehi, UT 84043

### Description:

Concrete block and gravel filter placed over inlet to storm drain system.

### Application:

Constructed at inlets in paved or unpaved areas where upgradient area is to be disturbed by construction activities.

### Installation / Application Criteria:

- Place wire mesh (with 1/2 inch openings) over the inlet grate extending one foot past the grate in all directions
- Place concrete blocks around the inlet with openings facing outward. Stack blocks to minimum height of 12-inches and maximum height of 24-inches
- Place wire mesh around outside of blocks
- Place gravel (3/4" to 3") around blocks

### Limitations:

- Recommended for maximum drainage area of one acre
- Excess flows may bypass the inlet, requiring down gradient controls
- Ponding will occur at inlet

### Maintenance:

- Inspect inlet protection after every large storm event and at a minimum of once monthly
- Remove sediment accumulated when it reaches 4-inches in depth
- Replace filter fabric and clean or replace gravel if clogging is apparent

# BMP: Inlet Protection – Combo Guard

IP-CG

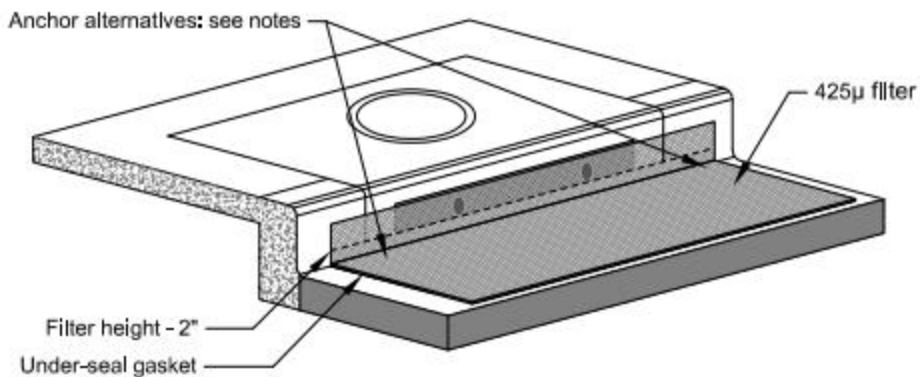

**ERTEC® Combo Guard™  
Protected drainage Inlet**

**Description:**

A temporary sediment filter made of high density polyethylene with an integrated filter. During construction, place device over the grate and curb opening of the drain inlet near disturbed soil.

**Application:**

- Recommended for use over curb & grate openings with small drainage areas.
- Drainage areas should be less than 1/3 acre and the total for inlets in series should be 1 acre or less with slopes flatter than 5 percent in the contributing drainage area.

**Installation / Application Criteria:**

Install system with the vertical section covering the curb inlet and the horizontal section covering the grate. 3 Acceptable Anchor Methods:

- Install gravel bags at each side – half on and half of the combo guard, or
- Attach with 16 gauge tie-wire at each corner. Feed wire through the combo guard, around grate bar and back up. Twist and snip excess, or
- Fasten with concrete anchors/nails at outside edges

**Limitations:**

- Cost
- Maintenance required to prevent plugging and to remain effective

**Maintenance:**

- Inspect inlet protection following storm event and at a minimum of once every 14 days
- Debris shall be removed daily and sediment shall be removed when the sediment accumulation reaches 2 inches.
- Removed sediment shall be incorporated in the project at designated locations or disposed-of outside the project or in conformance with requirements.
- Remove the device after final stabilization has been achieved.

**Objectives**

- Housekeeping Practices
- Contain Waste
- Minimize Disturbed Areas
- Stabilize Disturbed Areas
- Protect Slopes/Channels
- Control Site Perimeter
- Control Internal Erosion

**Targeted Pollutants**

**H M L**

- Sediment
- Nutrients
- Heavy Metals
- Toxic Materials
- Oil & Grease
- Floatable Materials
- Bacteria & Viruses
- Other Waste

**Implementation Requirements**

**H M L**

- Capital Costs
- O&M Costs
- Maintenance
- Training
- Staffing
- Administrative

**H=High M=Medium L=Low**



153 North 100 East  
Lehi, UT 84043

# BMP: Inlet Protection - Excavated

IP-E

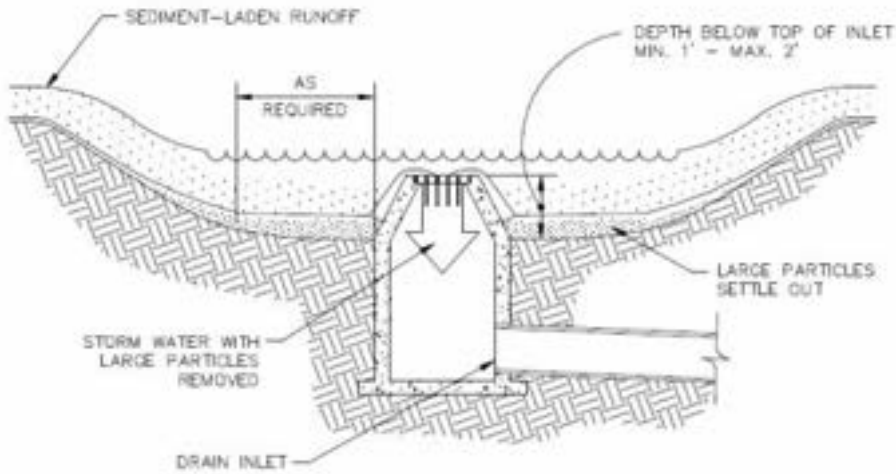

**Description:**

An area excavated around a storm drain inlet to impound water below the inlet.

**Application:**

- Construct at storm drainage inlets located downgradient of areas to be disturbed by construction (for inlets in paved areas see other information sheets for inlet protection)

**Installation / Application Criteria:**

- Provide upgradient sediment controls, such as silt fence during construction of inlet
- When construction of inlet is complete, excavate adjacent area 1 to 2 feet lower than the grate elevation. Size of excavated area should be based on soil type and contributing acreage

**Limitations:**

- Recommended maximum contributing drainage area of one acre
- Limited to inlets located in open unpaved areas
- Requires flat area adjacent to inlet

**Maintenance:**

- Inspect inlet protection following storm event and at a minimum of once monthly
- Remove accumulated sediment when it reaches one half of the excavated sump below the grate
- Repair side slopes as required

**Objectives**

- Housekeeping Practices
- Contain Waste
- Minimize Disturbed Areas
- Stabilize Disturbed Areas
- Protect Slopes/Channels
- Control Site Perimeter
- Control Internal Erosion

**Targeted Pollutants**

**H M L**

- Sediment
- Nutrients
- Heavy Metals
- Toxic Materials
- Oil & Grease
- Floatable Materials
- Bacteria & Viruses
- Other Waste

**Implementation Requirements**

**H M L**

- Capital Costs
- O&M Costs
- Maintenance
- Training
- Staffing
- Administrative

**H=High M=Medium L=Low**



153 North 100 East  
Lehi, UT 84043

# BMP: Inlet Protection - Gravel

IP

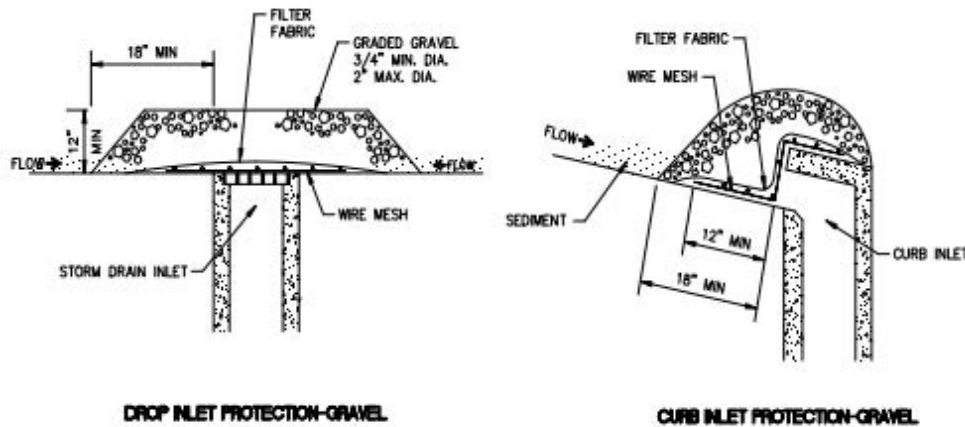

## Objectives

- Housekeeping Practices
- Contain Waste
- Minimize Disturbed Areas
- Stabilize Disturbed Areas
- Protect Slopes/Channels
- Control Site Perimeter
- Control Internal Erosion

## Targeted Pollutants

### H M L

- Sediment
- Nutrients
- Heavy Metals
- Toxic Materials
- Oil & Grease
- Floatable Materials
- Bacteria & Viruses
- Other Waste

## Implementation Requirements

### H M L

- Capital Costs
- O&M Costs
- Maintenance
- Training
- Staffing
- Administrative

H=High M=Medium L=Low

## Description:

Placement of gravel filter over inlet to storm drain to filter storm water runoff

## Application:

Construct at inlets in paved or unpaved areas where upgradient area is to be disturbed by construction activities.

## Installation / Application Criteria:

- Place wire mesh (with 1/2 inch openings) over the inlet grate extending one foot past the grate in all directions
- Place filter fabric over the mesh. Filter fabric should be selected based on soil type
- Place graded gravel, to a minimum depth of 12-inches, over the filter fabric and extending 18-inches past the grate in all directions

## Limitations:

- Recommended for maximum drainage area of one acre
- Excess flows may bypass the inlet requiring down gradient controls
- Ponding will occur at inlet

## Maintenance:

- Inspect inlet protection after every large storm even and at a minimum of once every two weeks
- Remove sediment accumulated when it reaches 4-inches in depth
- Replace filter fabric and clean or replace gravel if clogging is apparent



153 North 100 East  
Lehi, UT 84043

# BMP: Inlet Protection – Gravel Bags

IP-GB

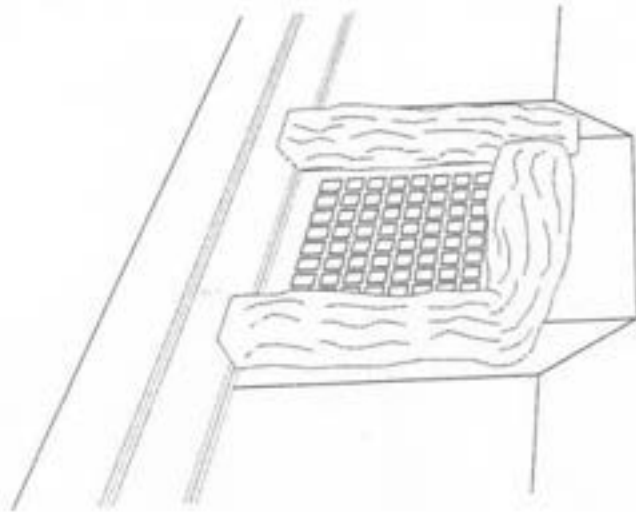

**Description:**

Sediment barrier erected around storm drain inlet.

**Application:**

Construct at storm drainage inlets located down-gradient of areas to be disturbed by construction

**Installation / Application Criteria:**

- Provide up-gradient sediment controls, such as silt fence during construction of inlet
- When construction of curb and gutter and roadway is complete, install gravel filled bags around perimeter of inlet
- Fill to recommended levels to reduce splitting of bags

**Limitations:**

- Recommended maximum contributing drainage area of one acre
- Requires shallow slopes adjacent to inlet

**Maintenance:**

- Inspect inlet protection following storm event and at a minimum of once every 14 days
- Remove accumulated sediment when it reaches half the height of the bag
- Look for bypassing or undercutting and repair or realign as needed
- Replace and clean up spilled gravel when bags split

**Objectives**

- Housekeeping Practices
- Contain Waste
- Minimize Disturbed Areas
- Stabilize Disturbed Areas
- Protect Slopes/Channels
- Control Site Perimeter
- Control Internal Erosion

**Targeted Pollutants**

**H M L**

- Sediment
- Nutrients
- Heavy Metals
- Toxic Materials
- Oil & Grease
- Floatable Materials
- Bacteria & Viruses
- Other Waste

**Implementation Requirements**

**H M L**

- Capital Costs
- O&M Costs
- Maintenance
- Training
- Staffing
- Administrative

H=High M=Medium L=Low



153 North 100 East  
Lehi, UT 84043

## BMP: Inlet Protection – Silt Bags

IP-SB

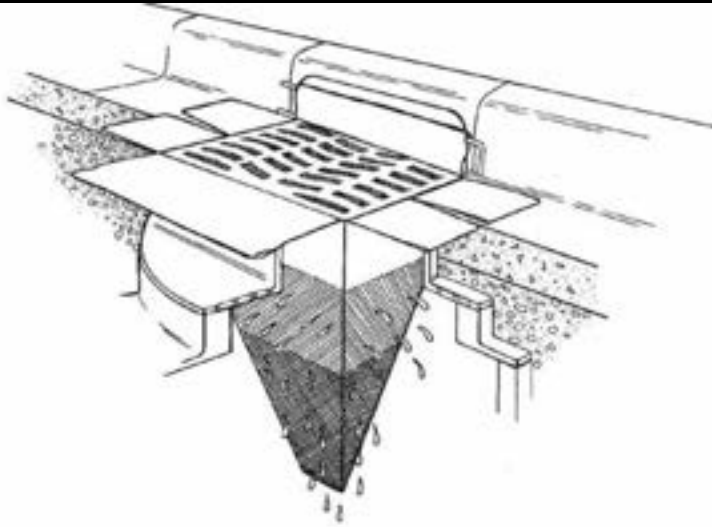

### Description:

Collect and trap sediment and debris entering catch basins from either grated or curb inlets. Insert is made of fabric and is placed in the drain inlet around the perimeter of the grate. Runoff passes through the bag before discharging into the drain outlet pipe. Overflow holes are usually provided to pass larger flows without causing a backwater at the grate. Certain manufactured products include polymers intended to increase pollutant removal effectiveness.

### Application:

- Storm drain inlet boxes

### Installation / Application Criteria:

- Regular maintenance is necessary
- Evaluation of the device chosen should be balanced with cost
- Hydraulic capacity controls effectiveness
- Most useful in small drainage areas (< 1 acre)
- Ideal in combination with other BMPs

### Limitations:

- Cost
- Maintenance required to prevent plugging and to remain effective

### Maintenance:

- Inspect inlet protection following storm event and at a minimum of once every 14 days
- Remove bag and empty accumulated sediment as necessary

### Objectives

- Housekeeping Practices
- Contain Waste
- Minimize Disturbed Areas
- Stabilize Disturbed Areas
- Protect Slopes/Channels
- Control Site Perimeter
- Control Internal Erosion

### Targeted Pollutants

#### H M L

- Sediment
- Nutrients
- Heavy Metals
- Toxic Materials
- Oil & Grease
- Floatable Materials
- Bacteria & Viruses
- Other Waste

### Implementation Requirements

#### H M L

- Capital Costs
- O&M Costs
- Maintenance
- Training
- Staffing
- Administrative

H=High M=Medium L=Low



153 North 100 East  
Lehi, UT 84043

# BMP: Inlet Protection – Silt Fence or Straw Bale

IP-SF

STRAW BALE BARRIER

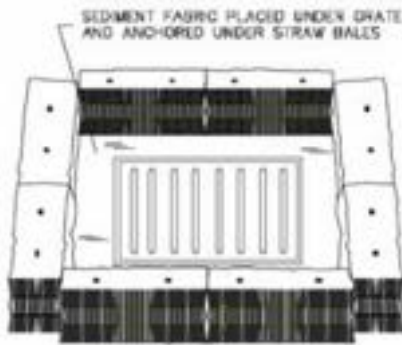

SILT FENCE

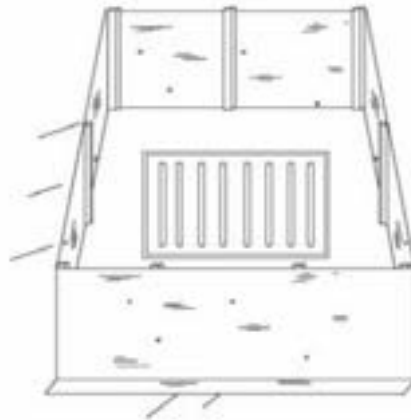

**Description:**

Sediment barrier erected around storm drain inlet.

**Application:**

Construct at storm drainage inlets located downgradient of areas to be disturbed by construction (for inlets in paved areas see other information sheets for inlet protection)

**Installation / Application Criteria:**

- Provide upgradient sediment controls, such as silt fence during construction of inlet
- When construction of inlet is complete, erect straw bale barrier or silt fence surrounding perimeter of inlet. Follow instructions and guidelines on individual BMP information sheets for straw bale barrier and silt fence construction

**Limitations:**

- Recommended maximum contributing drainage area of one acre
- Limited to inlets located in open unpaved areas
- Requires shallow slopes adjacent to inlet

**Maintenance:**

- Inspect inlet protection following storm event and at a minimum of once every 14 days
- Removed accumulated sediment when it reaches 4" in depth
- Repair or realign barrier/fence as needed
- Look for bypassing or undercutting and recompact soil around barrier/fence as required

**Objectives**

- Housekeeping Practices
- Contain Waste
- Minimize Disturbed Areas
- Stabilize Disturbed Areas
- Protect Slopes/Channels
- Control Site Perimeter
- Control Internal Erosion

**Targeted Pollutants**

**H M L**

- Sediment
- Nutrients
- Heavy Metals
- Toxic Materials
- Oil & Grease
- Floatable Materials
- Bacteria & Viruses
- Other Waste

**Implementation Requirements**

**H M L**

- Capital Costs
- O&M Costs
- Maintenance
- Training
- Staffing
- Administrative

H=High M=Medium L=Low



153 North 100 East  
Lehi, UT 84043

# BMP: Mulching

ML

## Objectives

- Housekeeping Practices
- Contain Waste
- Minimize Disturbed Areas
- Stabilize Disturbed Areas
- Protect Slopes/Channels
- Control Site Perimeter
- Control Internal Erosion

## Targeted Pollutants

### H M L

- Sediment
- Nutrients
- Heavy Metals
- Toxic Materials
- Oil & Grease
- Floatable Materials
- Bacteria & Viruses
- Other Waste

## Implementation Requirements

### H M L

- Capital Costs
- O&M Costs
- Maintenance
- Training
- Staffing
- Administrative

H=High M=Medium L=Low



153 North 100 East  
Lehi, UT 84043

Material	Application	Depth	Comments
<u>Gravel:</u> Washed 1/4" to 1-1/2"	9 cy/1000 s f	3 inches	Good for traffic areas Good for short slopes
<u>Straw:</u> Air-dried, free of seeds and coarse material	2-3 bales /1000 s f	2 inches min.	Subject to wind blowing Pack down or keep moist
<u>Wood Fiber Cellulose:</u> Free from growth inhibitors; dyed green	35 lb/1000 s f	1 inch	For critical areas, double application rate; Limit to slopes < 3% and < 150 feet

### Description:

Placement of material such as straw, grass, woodchips, wood fibers, or fabricated matting over open area.

### Application:

- Any exposed area to remain untouched longer than 14 days and that will be exposed less than 60 days (seed areas to be exposed in excess of 60 days)
- Areas that have been seeded
- Stockpiled soil material

### Installation / Application Criteria:

- Roughen area to receive mulch to create depressions that mulch material can settle into
- Apply mulch to required thickness and anchor as necessary
- Ensure material used is weed free and does not contain any constituents that will inhibit plant growth

### Limitations:

- Anchoring may be required to prevent migration of mulch material
- Downgradient control may be required to prevent mulch material being transported to storm water system

### Maintenance:

- Inspect mulched areas after every rainfall event and at a minimum of every 14 days
- Replace mulch on any bare areas and re-anchor as necessary
- Clean and replace downgradient controls as necessary

# BMP: Materials Storage

MS

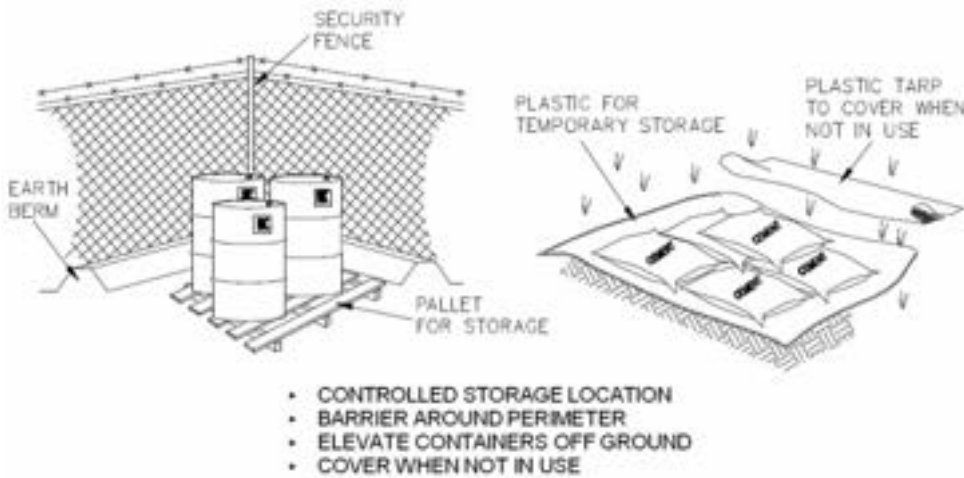

**Description:**

Controlled storage of on-site materials.

**Application:**

- Storage of hazardous, toxic, and all chemical substances
- Any construction site with outside storage of materials

**Installation / Application Criteria:**

- Designate a secured area with limited access as the storage location. Ensure no waterways or drainage paths are nearby
- Construct compacted earthen berm (see earth berm barrier information sheet), or similar perimeter containment around storage location for impoundment in the case of spills
- Ensure all on-site personnel utilize designated storage area. Do not store excessive amounts of material that will not be utilized on site
- For active use of materials away from the storage area, ensure materials are not set directly on the ground and are covered when not in use.

**Limitations:**

- Does not prevent contamination due to mishandling of products
- Spill Prevention and Response Plan still required
- Only effective if materials are actively stored in controlled location

**Maintenance:**

- Inspect daily and repair any damage to perimeter impoundment or security fencing
- Check that material are being correctly stored (i.e. standing upright, in labeled containers, tightly capped) and that no materials are being stored away from the designated location

**Objectives**

- Housekeeping Practices
- Contain Waste
- Minimize Disturbed Areas
- Stabilize Disturbed Areas
- Protect Slopes/Channels
- Control Site Perimeter
- Control Internal Erosion

**Targeted Pollutants**

**H M L**

- Sediment
- Nutrients
- Heavy Metals
- Toxic Materials
- Oil & Grease
- Floatable Materials
- Bacteria & Viruses
- Other Waste

**Implementation Requirements**

**H M L**

- Capital Costs
- O&M Costs
- Maintenance
- Training
- Staffing
- Administrative

H=High M=Medium L=Low



153 North 100 East  
 Lehi, UT 84043

# BMP: Outlet Protection

OP



**Description:**

A rock outlet protection is a physical device composed of rock or grouted riprap which is placed at the outlet of a pipe to prevent scour of the soil caused by high pipe flow velocities, and to absorb flow energy to produce nonerosive velocities.

**Application:**

- Wherever discharge velocities and energies at the outlets of culverts, conduits, or channels are sufficient to erode the next downstream reach
- Rock outlet protection is best suited for temporary use during construction because it is usually less expensive and easier to install than concrete aprons or energy dissipators
- A sediment trap below the pipe outlet is recommended if runoff is sediment laden
- Permanent rock riprap protection should be designed and sized by the engineer as part of the culvert, conduit, or channel design
- Grouted riprap should be avoided in areas of freeze and thaw because the grout will break up

**Installation / Application Criteria:**

Rock outlet protection is effective when the rock is sized and placed properly. When this is accomplished, rock outlets do much to limit erosion at pipe outlets. Rock size should be increased for high velocity flows. Best results are obtained when sound, durable, angular rock is used.

**Limitations:**

- Large storms often wash away the rock outlet protection and leave the area susceptible to erosion
- Sediment captured by the rock outlet protection may be difficult to remove without removing the rock
- Outlet protection may negatively impact the channel habitat

**Maintenance:**

- Inspect after each significant rain for erosion and/or disruption of the rock, and repair immediately
- Grouted or wire-tied rock riprap can minimize maintenance requirements

**Objectives**

- Housekeeping Practices
- Contain Waste
- Minimize Disturbed Areas
- Stabilize Disturbed Areas
- Protect Slopes/Channels
- Control Site Perimeter
- Control Internal Erosion

**Targeted Pollutants**

**H M L**

- Sediment
- Nutrients
- Heavy Metals
- Toxic Materials
- Oil & Grease
- Floatable Materials
- Bacteria & Viruses
- Other Waste

**Implementation Requirements**

**H M L**

- Capital Costs
- O&M Costs
- Maintenance
- Training
- Staffing
- Administrative

H=High M=Medium L=Low



153 North 100 East  
Lehi, UT 84043

# BMP: Oil/Water Separators and Water Quality Inlets

OWS

## Objectives

- Housekeeping Practices
- Contain Waste
- Minimize Disturbed Areas
- Stabilize Disturbed Areas
- Protect Slopes/Channels
- Control Site Perimeter
- Control Internal Erosion

## Targeted Pollutants

### H M L

- Sediment
- Nutrients
- Heavy Metals
- Toxic Materials
- Oil & Grease
- Floatable Materials
- Bacteria & Viruses
- Other Waste

## Implementation Requirements

### H M L

- Capital Costs
- O&M Costs
- Maintenance
- Training
- Staffing
- Administrative

H=High M=Medium L=Low



153 North 100 East  
Lehi, UT 84043

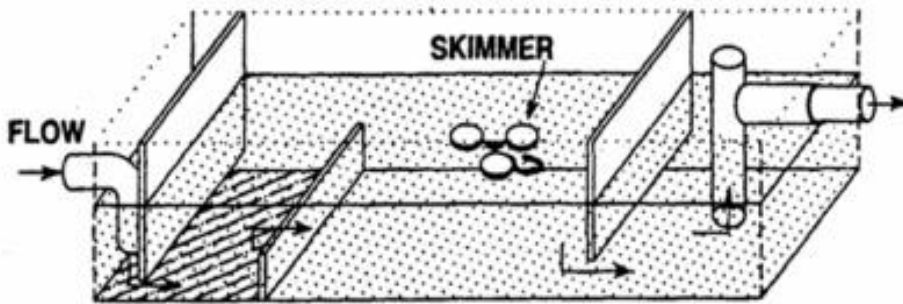

### Description:

Oil/water separators are designed to remove a specific group of contaminants: petroleum compounds and grease. However, separators will also remove floatable debris and settleable solids. Two general types of oil/water separators are used: conventional gravity separator and the coalescing plate interceptor (CPI).

### Application:

- Applicable to situations where the concentration of oil and grease related compounds is abnormally high and source control cannot provide effective control. The general types of businesses where this situation is likely are truck, car, and equipment maintenance and washing businesses, as well as businesses that perform maintenance on their own equipment and vehicles
- Public facilities where separators may be required include marine ports, airfields, fleet vehicle maintenance and washing facilities, and mass transit park-and-ride lots
- Conventional separators are capable of removing oil droplets with diameters equal to or greater than 150 microns
- A CPI separator should be used if smaller droplets must be removed

### Installation / Application Criteria:

- Sizing relates to anticipated influent oil concentration, water temperature and velocity, and the effluent goal.
- To maintain a reasonable separator size, it should be designed to bypass flows in excess of first flush.

### Limitations:

- The lack of data on oil characteristics in stormwater leads to considerable uncertainty about performance
- An air quality permit may be required

### Maintenance:

Clean accumulated oil, grease, and floating debris frequently.

# BMP: Preservation of Existing Vegetation

PEV

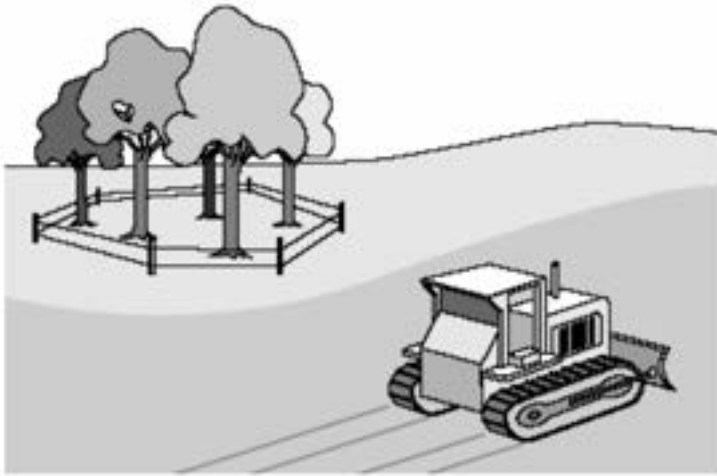

### Description:

Carefully planned preservation of existing vegetation minimizes the potential of removing or injuring existing trees, vines, shrubs, and/or grasses that serve as erosion controls.

### Application:

This technique is applicable to all types of sites. Areas where preserving vegetation can be particularly beneficial are floodplains, wetlands, stream banks, steep slopes, and other areas where erosion controls would be difficult to establish, install, or maintain.

### Installation / Application Criteria:

- Clearly mark, flag, or fence vegetation or areas where vegetation should be preserved
- Prepare landscaping plans which include as much existing vegetation as possible and state proper care during and after construction
- Define and protect a setback area from vegetation to be preserved with berms, fencing, signs, etc.
- Propose landscaping plans which do not include plant species that compete with the existing vegetation
- Do not locate construction traffic routes, spoil piles, etc. where significant adverse impact on existing vegetation may occur.

### Limitations:

- Requires forward planning by the owner/developer, contractor, and design staff
- For sites with diverse topography, it is often difficult and expensive to save existing trees while grading the site satisfactorily for the planned development
- May not be cost effective with high land costs

### Maintenance:

- Inspection and maintenance requirements for protection of vegetation are low
- Maintenance of native trees or vegetation should conform to landscape plan specifications

### Objectives

- Housekeeping Practices
- Contain Waste
- Minimize Disturbed Areas
- Stabilize Disturbed Areas
- Protect Slopes/Channels
- Control Site Perimeter
- Control Internal Erosion

### Targeted Pollutants

#### H M L

- Sediment
- Nutrients
- Heavy Metals
- Toxic Materials
- Oil & Grease
- Floatable Materials
- Bacteria & Viruses
- Other Waste

### Implementation Requirements

#### H M L

- Capital Costs
- O&M Costs
- Maintenance
- Training
- Staffing
- Administrative

H=High M=Medium L=Low



153 North 100 East  
Lehi, UT 84043

## BMP: Parking Lot Design

PLD



### Description:

Consider available design options to reduce the quantity and improve the quality of storm water runoff from parking lots. Related practices include filter strips, biofilters, grassed swales, and sediment traps.

### Considerations:

- Shared parking reduces the total number of parking spaces needed for businesses adjacent to each other. Businesses having parking demand during the day on weekdays (such as office buildings) can often share parking spaces with businesses having weekend or evening parking demands (such as restaurants or movie theaters)
- The use of landscaped islands in parking lots reduces to the total impervious area of the parking lot, reducing the quantity of storm water runoff
- Some parking lots can be designed such that storm water runoff flows across a landscaped area prior to being collected. This can both reduce the quantity of runoff and improve the quality of runoff
- Include structural practices in parking lot design to reduce storm water runoff contamination. Examples include sediment traps in inlet boxes, oil/water separators, water quality inlets, and passing storm water over vegetation
- Parking lots should not be larger than is necessary – they should provide adequate, but not excessive, parking
- Technologies are available that allow for a natural turf surface on parking lots. Such surfaces support traffic loads and can be plowed of snow in the winter. They are generally used for overflow parking but can be used for primary parking as well. Grass pavement can both reduce storm water runoff and improve storm water runoff quality

### Limitations:

- Parking lot design is specific to each development site; some considerations may not apply on some sites
- Shared parking is only viable where complimentary businesses are located adjacent to one another

### Objectives

- Housekeeping Practices
- Contain Waste
- Minimize Disturbed Areas
- Stabilize Disturbed Areas
- Protect Slopes/Channels
- Control Site Perimeter
- Control Internal Erosion

### Targeted Pollutants

#### H M L

- Sediment
- Nutrients
- Heavy Metals
- Toxic Materials
- Oil & Grease
- Floatable Materials
- Bacteria & Viruses
- Other Waste

### Implementation Requirements

#### H M L

- Capital Costs
- O&M Costs
- Maintenance
- Training
- Staffing
- Administrative

H=High M=Medium L=Low



153 North 100 East  
Lehi, UT 84043

# BMP: Portable Toilets

PT

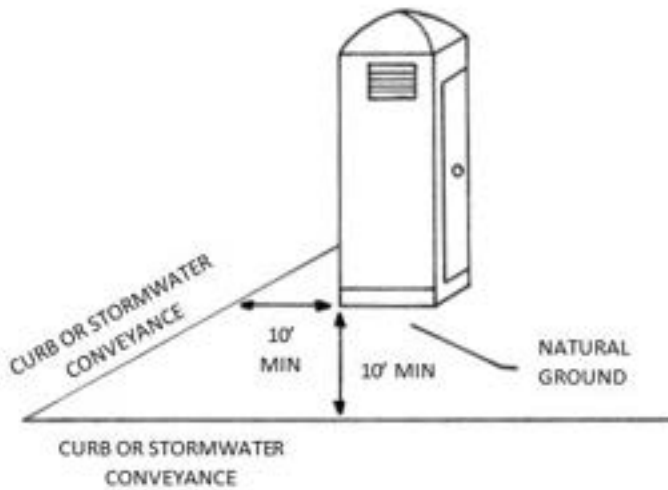

**Description:**

Temporary on-site sanitary facilities for construction personnel.

**Application:**

All sites with no permanent sanitary facilities or where permanent facility is too far from activities.

**Installation / Application Criteria:**

- Locate portable toilets at least 10 feet from any storm water conveyance, inlet, curb and gutter, or conduit to a waterway
- If it is not possible to maintain at least 10 feet of separation, additional controls such as secondary containment, additional surface preparation, or berms may be needed
- Portable toilets should be secured so they will not tip over

**Limitations:**

No limitations

**Maintenance:**

- Portable toilets should be maintained in good working order by licensed service with daily observation for leak detection
- Regular waste collection should be arranged with licensed service
- All waste should be deposited in sanitary sewer system for treatment with appropriate agency approval

**Objectives**

- Housekeeping Practices
- Contain Waste
- Minimize Disturbed Areas
- Stabilize Disturbed Areas
- Protect Slopes/Channels
- Control Site Perimeter
- Control Internal Erosion

**Targeted Pollutants**

**H M L**

- Sediment
- Nutrients
- Heavy Metals
- Toxic Materials
- Oil & Grease
- Floatable Materials
- Bacteria & Viruses
- Other Waste

**Implementation Requirements**

**H M L**

- Capital Costs
- O&M Costs
- Maintenance
- Training
- Staffing
- Administrative

H=High M=Medium L=Low



153 North 100 East  
 Lehi, UT 84043



**Description:**

Riprap is a permanent, erosion-resistant protective layer made of loose stones. It is intended to protect soil from erosion in areas of concentrated runoff. Riprap may also be used to stabilize slopes that are unstable because of seepage problems.

**Application:**

- Riprap is normally used at locations where erosive forces from water flow exceed the ability of the soil or vegetative cover to resist those forces
- Riprap can be used for pipe outlet protection, channel lining, scour protection, etc.
- Riprap is commonly used for wave protection on lakes

**Installation / Application Criteria:**

- For slopes steeper than 2:1, consider using materials other than riprap for erosion protection
- If riprap is being planned for the bottom of a permanently flowing channel, the bottom can be modified to enhance fish habitat. This can be done by construction riffles and pools which simulate natural conditions
- When working within flowing streams, measures should be taken to prevent excessive turbidity and erosion during construction. Bypassing base flows or temporarily blocking base flows are two possible methods. Work should be done during a period of low flow.

In designing riprap consider the following:

- Use durable rock, such as granite, and a variety of rock sizes
- The thickness of riprap layers should be at least 1.25 times the max stone diameter
- Filter material is usually required between riprap and the underlying soil surface

**Limitations:**

- Riprap may be unstable on very steep slopes
- The placement of a riprap in streams requires a state stream alteration permit

**Maintenance:**

- Riprap should be inspected annually and after major storms
- If riprap has been damaged, repairs should be made promptly to prevent a progressive failure
- If repairs are needed repeatedly at one location, the site should be evaluated to see if original design conditions have changed

**Objectives**

- Housekeeping Practices
- Contain Waste
- Minimize Disturbed Areas
- Stabilize Disturbed Areas
- Protect Slopes/Channels
- Control Site Perimeter
- Control Internal Erosion

**Targeted Pollutants**

**H M L**

- Sediment
- Nutrients
- Heavy Metals
- Toxic Materials
- Oil & Grease
- Floatable Materials
- Bacteria & Viruses
- Other Waste

**Implementation Requirements**

**H M L**

- Capital Costs
- O&M Costs
- Maintenance
- Training
- Staffing
- Administrative

**H=High M=Medium L=Low**



153 North 100 East  
Lehi, UT 84043

# BMP: Sediment Basin

SB

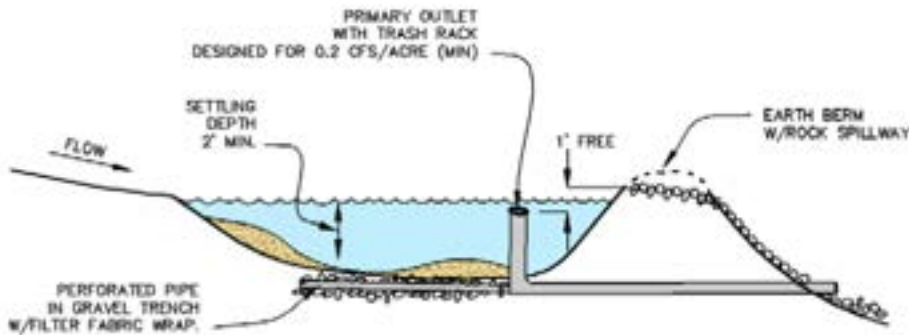

**Description:**

A pond created by excavation or construction of an embankment designed to retain or detain runoff sufficiently to allow excessive sediment to settle.

**Application:**

- At the outlet of all disturbed watersheds 10 acres or larger
- At the outlet of smaller disturbed watersheds, as necessary
- Where post construction detention basins will be located

**Installation / Application Criteria:**

- Design basin for site specific location, maintain effective flow length 2 times width
- Excavate basin or construct compacted berm containment; ensure no downgradient hazard if failure should occur. (Provide minimum of 67 cy. per acre of drainage area)

**Limitations:**

- Should be sized based on anticipated runoff, sediment loading and drainage area size
- May require silt fence at outlet for entrapment of very fine silts and clays
- May require safety fencing to prevent public access
- Height restrictions for embankments is regulated by Utah Division of Dam Safety

**Maintenance:**

- Inspect after each rainfall event and at a minimum of once every two weeks
- Repair any damage to berm, spillway or sidewalls
- Remove accumulated sediment as it reaches 2/3 height of available storage
- Check outlet for sedimentation/erosion of downgradient area and remediate as necessary. Install silt fence if sedimentation is apparent

**Objectives**

- Housekeeping Practices
- Contain Waste
- Minimize Disturbed Areas
- Stabilize Disturbed Areas
- Protect Slopes/Channels
- Control Site Perimeter
- Control Internal Erosion

**Targeted Pollutants**

**H M L**

- Sediment
- Nutrients
- Heavy Metals
- Toxic Materials
- Oil & Grease
- Floatable Materials
- Bacteria & Viruses
- Other Waste

**Implementation Requirements**

**H M L**

- Capital Costs
- O&M Costs
- Maintenance
- Training
- Staffing
- Administrative

H=High M=Medium L=Low



153 North 100 East  
Lehi, UT 84043

## BMP: Sand Bag Barrier

SBB

### Objectives

- Housekeeping Practices
- Contain Waste
- Minimize Disturbed Areas
- Stabilize Disturbed Areas
- Protect Slopes/Channels
- Control Site Perimeter
- Control Internal Erosion

### Targeted Pollutants

#### H M L

- Sediment
- Nutrients
- Heavy Metals
- Toxic Materials
- Oil & Grease
- Floatable Materials
- Bacteria & Viruses
- Other Waste

### Implementation Requirements

#### H M L

- Capital Costs
- O&M Costs
- Maintenance
- Training
- Staffing
- Administrative

H=High M=Medium L=Low



153 North 100 East  
Lehi, UT 84043

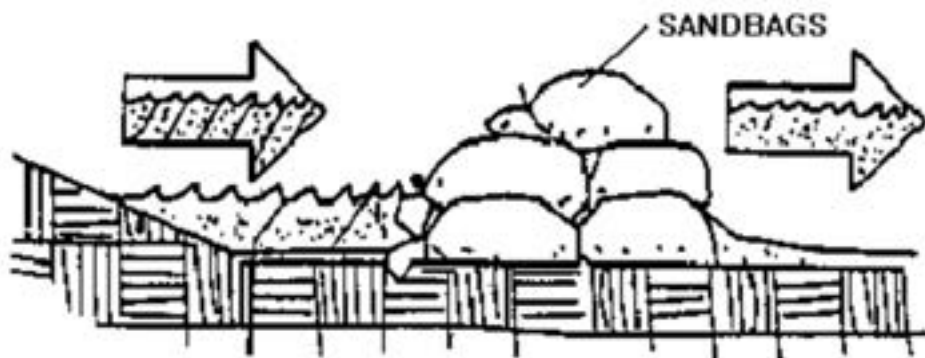

### Description:

Stacking sand bags along a level contour creates a barrier which detains sediment-laden water, ponding water upstream of the barrier and promoting sedimentation.

### Application:

- Along the perimeter of the site
- May be used in drainage areas up to 5 acres
- Along streams and channels
- Across swales with small catchments
- Around temporary spoil areas
- Below the toe of a cleared slope

### Installation / Application Criteria:

- Install along a level contour
- Base of sand bag barrier should be at least 48" wide
- Height of sand bag barrier should be at least 18" high
- 4" PVC pipe may be installed between the top layer of sand bags to drain large flood flows
- Provide area behind barrier for runoff to pond and sediment to settle
- Place below to toe of a slope
- UV resistant bags should be used

### Limitations:

- Sand bags are more expensive than other barriers, but also more durable
- Burlap should not be used

### Maintenance:

- Inspect after each rain event and a minimum of once every two weeks
- Reshape or replace damaged sand bags immediately
- Remove buildup of sediment

# BMP: Straw Bale Barrier

SBB

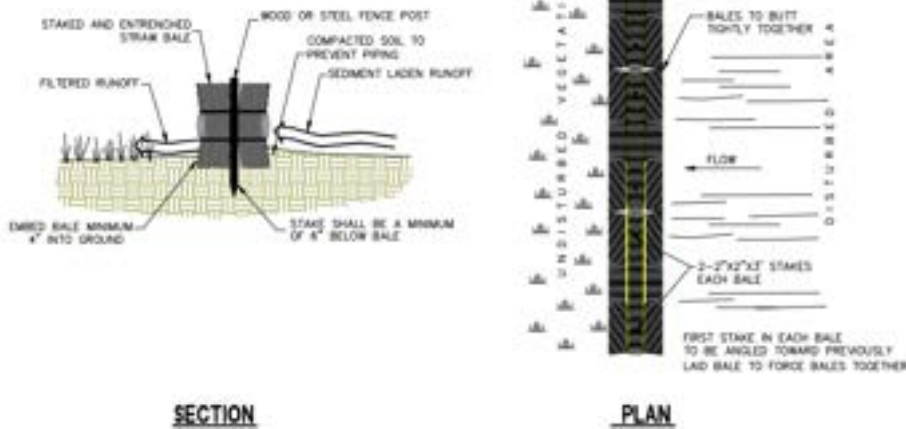

**Description:**

Temporary sediment barrier consisting of a row of entrenched and anchored straw bales.

**Application:**

- Perimeter Control: place barrier at downgradient limits of disturbance
- Sediment Barrier: place barrier at toe of slope or soil stockpile
- Protection of Existing Waterways: place barrier at top of stream bank
- Inlet Protection

**Installation / Application Criteria:**

- Excavate a 4" minimum deep trench along contour line, i.e., parallel to slope, removing all grass and other material that may allow underflow
- Place bales in trench with ends tightly abutting; fill any gaps by wedging loose straw into openings
- Anchor each bale and compact to prevent piping; backing on uphill side to be built up 4" above ground at the barrier

**Limitations:**

- Recommended maximum area of 0.5 acre per 100' of barrier
- Recommended maximum upgradient slope length of 150 feet
- Recommended maximum uphill grade of 2:1 (50%)
- Maximum duration of use is 6 months

**Maintenance:**

- Inspect immediately after any rainfall event and at least daily during prolonged rainfall
- Look for runoff bypassing ends of barriers or undercutting barriers
- Repair or replace damaged areas of the barrier and remove accumulated sediment
- Realign bales as necessary to provide continuous barrier and fill gaps
- Recompact soil around barrier as necessary to prevent piping

**Objectives**

- Housekeeping Practices
- Contain Waste
- Minimize Disturbed Areas
- Stabilize Disturbed Areas
- Protect Slopes/Channels
- Control Site Perimeter
- Control Internal Erosion

**Targeted Pollutants**

**H M L**

- Sediment
- Nutrients
- Heavy Metals
- Toxic Materials
- Oil & Grease
- Floatable Materials
- Bacteria & Viruses
- Other Waste

**Implementation Requirements**

**H M L**

- Capital Costs
- O&M Costs
- Maintenance
- Training
- Staffing
- Administrative

H=High M=Medium L=Low



153 North 100 East  
Lehi, UT 84043

# BMP: Street Cleaning

SC



**Description:**

Prevent sediment from entering storm water by sweeping the streets near construction activities.

**Application:**

- Useful for any paved streets near construction sites where sediment is blown, tracked, or spilled onto the streets

**Installation / Application Criteria:**

- The equipment used should be appropriate for the conditions. Vacuum sweepers work more effectively when the area is dry. Brush sweepers work better when the sediment is wet or stuck to the surface
- Mechanical equipment should be operated and maintained according to the manufacturer's recommendations

**Limitations:**

- Is labor and equipment intensive
- May cause dust

**Maintenance:**

The street should be checked daily for any sediment deposits. Street sweeping should be implemented whenever sediment from construction activity is found on the streets.

**Objectives**

- Housekeeping Practices
- Contain Waste
- Minimize Disturbed Areas
- Stabilize Disturbed Areas
- Protect Slopes/Channels
- Control Site Perimeter
- Control Internal Erosion

**Targeted Pollutants**

**H M L**

- Sediment
- Nutrients
- Heavy Metals
- Toxic Materials
- Oil & Grease
- Floatable Materials
- Bacteria & Viruses
- Other Waste

**Implementation Requirements**

**H M L**

- Capital Costs
- O&M Costs
- Maintenance
- Training
- Staffing
- Administrative

H=High M=Medium L=Low



153 North 100 East  
Lehi, UT 84043

# BMP: Stabilized Construction Entrance

SCE

## Objectives

- Housekeeping Practices
- Contain Waste
- Minimize Disturbed Areas
- Stabilize Disturbed Areas
- Protect Slopes/Channels
- Control Site Perimeter
- Control Internal Erosion

## Targeted Pollutants

### H M L

- Sediment
- Nutrients
- Heavy Metals
- Toxic Materials
- Oil & Grease
- Floatable Materials
- Bacteria & Viruses
- Other Waste

## Implementation Requirements

### H M L

- Capital Costs
- O&M Costs
- Maintenance
- Training
- Staffing
- Administrative

H=High M=Medium L=Low



153 North 100 East  
Lehi, UT 84043

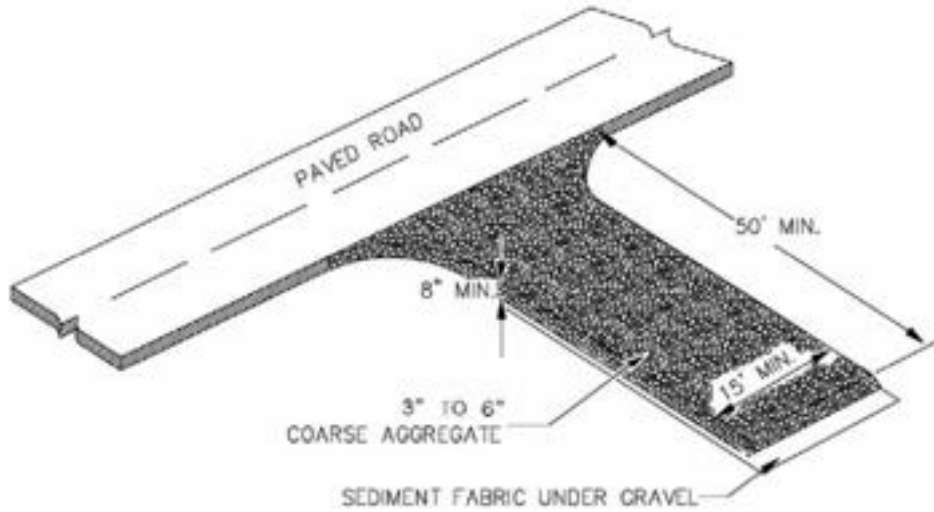

### Description:

A stabilized pad of crushed stone located where construction traffic enters or leaves the site from or to paved surfaces.

### Application:

At any point of ingress and egress at a construction site where adjacent traveled way is paved. Generally applies to sites over 2 acres unless special conditions exist.

### Installation / Application Criteria:

- Clear and grub area and grade to provide maximum slope of 2%
- Compact subgrade and place filter fabric if desired (recommended for entrances to remain for more than 3 months)
- Place coarse aggregate, 3-6 inches in size, to a minimum depth of 8 inches

### Limitations:

- Requires periodic top dressing with additional stones
- Should be used in conjunction with street sweeping on adjacent public right-of-way

### Maintenance:

- Inspect daily for loss of gravel or sediment buildup
- Inspect adjacent roadway for sediment deposit and clean by sweeping or shoveling
- Repair entrance and replace gravel as required to maintain control in good working condition
- Expand stabilized area as required to accommodate traffic and prevent erosion at driveways

# BMP: Spill Clean-Up

SCU

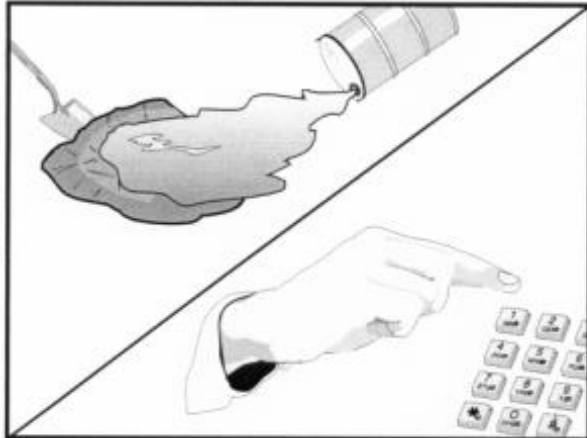

Standard Symbol

- BMP Objectives**
- Soil Stabilization
  - Sediment Control
  - Tracking Control
  - Wind Erosion Control
  - Non-Storm Water Management
  - Materials and Waste Management

## Objectives

- Housekeeping Practices
- Contain Waste
- Minimize Disturbed Areas
- Stabilize Disturbed Areas
- Protect Slopes/Channels
- Control Site Perimeter
- Control Internal Erosion

## Targeted Pollutants

### H M L

- Sediment
- Nutrients
- Heavy Metals
- Toxic Materials
- Oil & Grease
- Floatable Materials
- Bacteria & Viruses
- Other Waste

## Implementation Requirements

### H M L

- Capital Costs
- O&M Costs
- Maintenance
- Training
- Staffing
- Administrative

H=High M=Medium L=Low



153 North 100 East  
Lehi, UT 84043

### Description:

Practices to clean-up leakage/spillage of on-site materials that may be harmful to receiving waters.

### Application:

All sites

### General:

- Store controlled materials within a storage area
- Educate personnel on prevention and clean-up
- Designate an Emergency Coordinator responsible for providing spill response
- Maintain a supply of clean-up equipment on-site as well as a list of response agencies with phone numbers

### Methods:

- Clean-up spills/leaks immediately and remediate cause
- Use as little water as possible. NEVER HOSE DOWN OR BURY SPILL CONTAMINATED MATERIAL
- Use rags or absorbent material for clean-up. Excavate contaminated soils. Dispose of clean-up material and soil as hazardous waste
- Document all spills with date, location, substance, volume, actions taken, and other pertinent data
- Contact local fire department and state division of environmental response and remediation for any spill of reportable quantity

# BMP: Slope Drain

SD

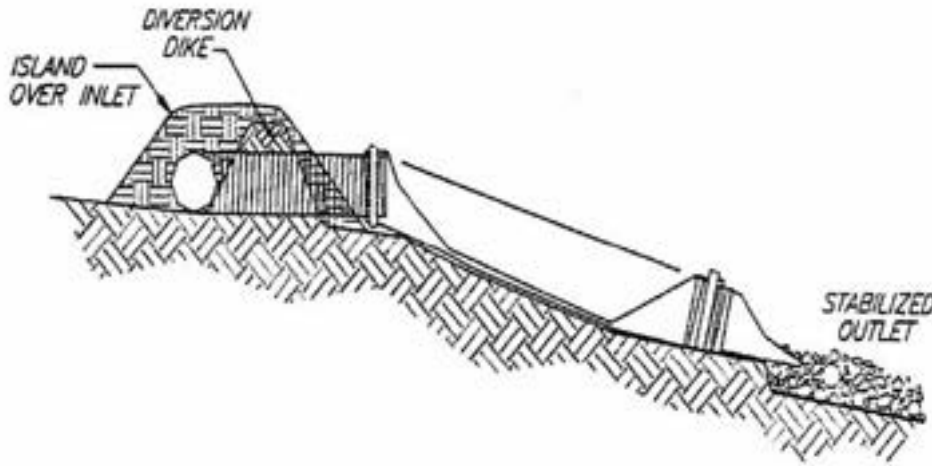

### Description:

A temporary pipe or lined channel that drains the top of a slope to a stable discharge point at the bottom of a slope without causing erosion.

### Application:

- Where concentrated flow or surface runoff must be conveyed down a slope in order to prevent erosion
- Emergency spillway for a sediment basin

### Installation / Application Criteria:

- Secure inlet and surround with dikes to prevent gully erosion, and anchor pipe to slope
- Size to convey at least the peak of a 10-year storm event
- Stabilize outlet (See Outlet Protection BMP)

### Limitations:

- Maximum drainage area per slope drain is 5 acres
- Clogged slope drains will force water around the pipe and cause slope erosion
- Dissipation of high flow velocities at the pipe outlet is required to avoid downstream erosion
- Failure can result in flooding and severe erosion

### Maintenance:

- Structure must be inspected weekly and after storms
- Inlet must be protected from undercutting and no water should circumvent the entry
- Outlet should not produce erosion; velocity dissipators must be maintained
- Pipe anchors must be checked to ensure that the pipe remains anchored to the slope

### Objectives

- Housekeeping Practices
- Contain Waste
- Minimize Disturbed Areas
- Stabilize Disturbed Areas
- Protect Slopes/Channels
- Control Site Perimeter
- Control Internal Erosion

### Targeted Pollutants

#### H M L

- Sediment
- Nutrients
- Heavy Metals
- Toxic Materials
- Oil & Grease
- Floatable Materials
- Bacteria & Viruses
- Other Waste

### Implementation Requirements

#### H M L

- Capital Costs
- O&M Costs
- Maintenance
- Training
- Staffing
- Administrative

H=High M=Medium L=Low



153 North 100 East  
Lehi, UT 84043

# BMP: Storm Drain Flushing

SDF



**Description:**

A storm drain is “flushed” with water to suspend and remove deposited materials. Flushing is particularly beneficial for storm drain pipes with grades too flat to be self-scouring. Flushing helps ensure pipes convey design flows and remove pollutants from the storm drain system.

**Approach:**

- Locate reaches of storm drain with deposit problems and develop a flushing schedule that keeps the pipe clear of excessive buildup
- Whenever possible, flushed effluent should be collected, decanted, evaporated, and disposed of in a landfill

**Limitations:**

- Most effective in small diameter pipes (36-inch diameter pipe or less, depending on water supply and sediment collection capacity)
- Water source must be available
- May have difficulty finding downstream area to collect sediments
- Requires liquid/sediment disposal

**Objectives**

- Housekeeping Practices
- Contain Waste
- Minimize Disturbed Areas
- Stabilize Disturbed Areas
- Protect Slopes/Channels
- Control Site Perimeter
- Control Internal Erosion

**Targeted Pollutants**

**H M L**

- Sediment
- Nutrients
- Heavy Metals
- Toxic Materials
- Oil & Grease
- Floatable Materials
- Bacteria & Viruses
- Other Waste

**Implementation Requirements**

**H M L**

- Capital Costs
- O&M Costs
- Maintenance
- Training
- Staffing
- Administrative

**H=High M=Medium L=Low**



153 North 100 East  
Lehi, UT 84043

# BMP: Storm Drain System Signs

SDSS

## Objectives

- Housekeeping Practices
- Contain Waste
- Minimize Disturbed Areas
- Stabilize Disturbed Areas
- Protect Slopes/Channels
- Control Site Perimeter
- Control Internal Erosion

## Targeted Pollutants

### H M L

- Sediment
- Nutrients
- Heavy Metals
- Toxic Materials
- Oil & Grease
- Floatable Materials
- Bacteria & Viruses
- Other Waste

## Implementation Requirements

### H M L

- Capital Costs
- O&M Costs
- Maintenance
- Training
- Staffing
- Administrative

H=High M=Medium L=Low



153 North 100 East  
Lehi, UT 84043



### Description:

Stenciling of the storm drain system (inlets, catch basins, channels, and creeks) with prohibitive language/graphic icons discourages the illegal dumping of unwanted materials.

### Approach:

- Create a volunteer work force to stencil storm drain inlets
- An important aspect of a stenciling program is the distribution of informational flyers that educate the neighborhood (business and residential) about stormwater pollution, the storm drain system, and the watershed. The flyers should also provide information on alternatives such as recycling, household hazardous waste disposal, and safer products
- Because a stenciling program primarily involves volunteer services, liability release forms and volunteer identification notices should also be administered
- Readability of stencils is critical to their effectiveness. Wherever possible, stencils should be painted on a smooth surface such as cement, as opposed to asphalt
- Use municipal staff to erect signs near drainage channels and creeks
- An effectively implemented stenciling program encourages change in personal behavior and helps minimize non-point source pollutants from entering the storm drain system. An additional benefit is that waste and catch basin maintenance is minimized through the reduction of disposed materials into storm drain inlets. Finally, a well implemented stenciling program encourages the use of household hazardous waste collection and used oil recycling programs

### Limitations:

- Private property access limits stenciling to publicly owned areas
- Program is highly dependent on volunteer response
- Storm drain inlets that are physically blocked will be missed or require follow-up
- High traffic/commercial/industrial zones are the responsibility of city staff
- Ongoing maintenance is needed to maintain readable signs

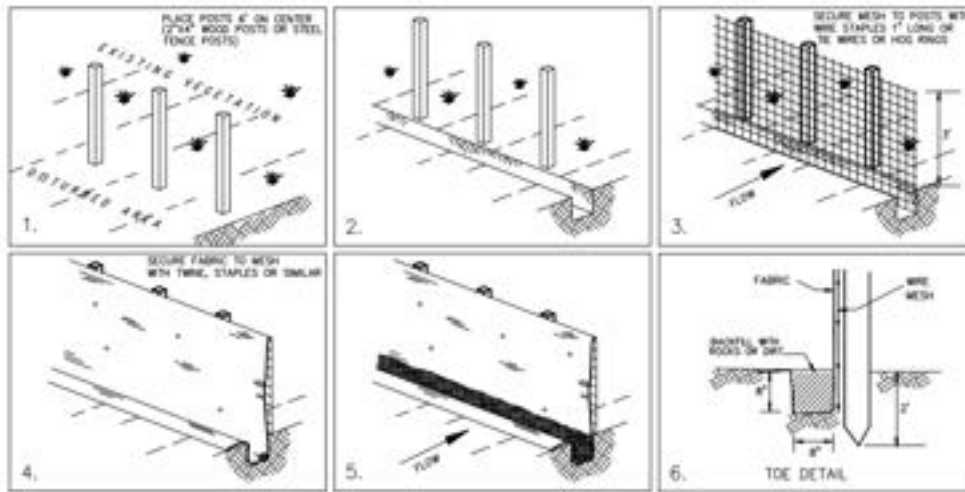

**Description:**

A temporary sediment barrier consisting of entrenched filter fabric stretched across and secured to supporting posts.

**Application:**

- Perimeter control: place barrier at downgradient limits of disturbance
- Sediment barrier: place barrier at toe of slope or soil stockpile
- Protection of existing waterways: place barrier at top of stream bank
- Inlet protection: place fence surrounding catch basins

**Installation / Application Criteria:**

- Place posts 6' apart on center along contour (or use preassembled unit) and drive 2' minimum into ground. Excavate an anchor trench immediately up gradient of posts
- Cut fabric to required width, unroll along length of barrier and drape over barrier. Secure fabric to mesh with twine, staples, or similar, with trailing edge extending into anchor trench
- Backfill trench over fabric to anchor
- Fabric must have 85% minimum sediment removal efficiency

**Limitations:**

- Recommended maximum drainage area of 0.5 acres per 100 feet
- Recommended maximum upgradient slope length of 150'
- Recommended maximum uphill grade of 2:1 (50%)
- Recommended maximum flow rate of 0.5 cfs
- Ponding should not be allowed behind fence

**Maintenance:**

- Inspect immediately after any rainfall and at least daily during prolonged rainfall
- Look for runoff bypassing ends of barriers or undercutting barriers
- Repair or replace damaged areas of the barrier and remove accumulated sediment
- Re-anchor fence as necessary to prevent shortcutting
- Remove accumulated sediment when it reaches 1/2 the height of the fence

**Objectives**

- Housekeeping Practices
- Contain Waste
- Minimize Disturbed Areas
- Stabilize Disturbed Areas
- Protect Slopes/Channels
- Control Site Perimeter
- Control Internal Erosion

**Targeted Pollutants**

**H M L**

- Sediment
- Nutrients
- Heavy Metals
- Toxic Materials
- Oil & Grease
- Floatable Materials
- Bacteria & Viruses
- Other Waste

**Implementation Requirements**

**H M L**

- Capital Costs
- O&M Costs
- Maintenance
- Training
- Staffing
- Administrative

**H=High M=Medium L=Low**



153 North 100 East  
Lehi, UT 84043

# BMP: Stockpile Management

SM

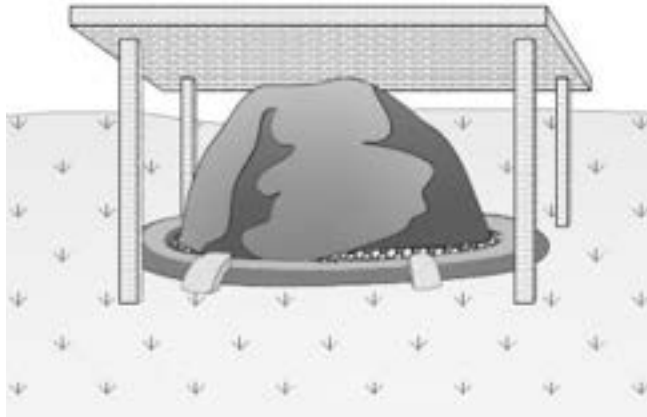

### Description:

Proper storage and management practices for stockpiles will reduce the potential for these materials to discharge into waterways.

### Application:

Construction sites with stockpiles material.

### Installation / Application Criteria:

- Locate stockpiles a least 100 feet from any storm water conveyance
- Follow CGP and air quality permit requirements for managing material stockpiles and minimizing dust generation
- Locate stockpiles on permeable surfaces where possible
- Do not stockpile materials in areas subject to ponding or standing water
- Use perimeter controls such as berms, fiber rolls, gravel bags, etc. to protect stockpiles from stormwater run-on and to minimize potential sediment discharges
- Water soluble materials (e.g., salt or lime) must not be stockpiled uncovered. Soluble chemicals must be stored indoors, or at a minimum fully covered with plastic sheeting, tarps, or other suitable protection at all times to prevent contact with precipitation and stormwater runoff
- Treated wood stockpiles shall be stored off the ground surface and covered to minimize exposure to precipitation and stormwater runoff
- Do not hose down or sweep waste stockpile materials into any waterway or stormwater conveyance
- Limit quantities of materials stockpiled onsite at any given time. Material should be staged and ordered in quantities that minimize the amount stored onsite

### Maintenance:

- Inspect stockpile protection following material use, following a rain event, and at least biweekly
- Monitor the weather forecast to determine the need to cover stockpiles materials
- Maintain or replace stockpile covers and controls as needed

### Objectives

- Housekeeping Practices
- Contain Waste
- Minimize Disturbed Areas
- Stabilize Disturbed Areas
- Protect Slopes/Channels
- Control Site Perimeter
- Control Internal Erosion

### Targeted Pollutants

#### H M L

- Sediment
- Nutrients
- Heavy Metals
- Toxic Materials
- Oil & Grease
- Floatable Materials
- Bacteria & Viruses
- Other Waste

### Implementation Requirements

#### H M L

- Capital Costs
- O&M Costs
- Maintenance
- Training
- Staffing
- Administrative

H=High M=Medium L=Low



153 North 100 East  
Lehi, UT 84043

# BMP: Seeding and Planting

SP

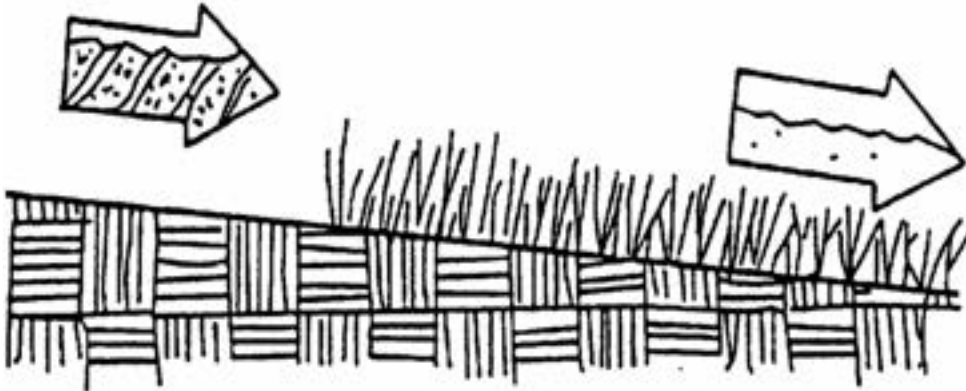

**Description:**

Seeding of grass and plantings of trees, shrubs, vines, and ground covers provide long-term stabilization of soil. In some areas, with suitable climates, grasses can be planted for temporary stabilization.

**Application:**

- Appropriate for site stabilization both during construction and post-construction
- Any graded/cleared areas where construction activities have ceased
- Open space cut and fill areas
- Steep slopes, spoil piles, vegetated swales, landscape corridors, stream banks. Use in conjunction with matting, mulch, or blanketing where appropriate.

**Installation / Application Criteria:**

Types of vegetation, site and seedbed preparation, planting time, fertilization and water requirement should be considered for each application.

**Grasses:**

- Ground preparations: fertilize and mechanically stabilize the soil
- Tolerant of short-term temperature extremes and waterlogged soil composition
- Appropriate soil conditions: shallow soil base, good drainage, slope 2:1 or flatter
- Mowing, irrigating, and fertilizing are vital for promoting vigorous grass growth

**Trees and Shrubs:**

- Selection criteria: vigor, species, size, shape, and wildlife food source
- Soil conditions: select species appropriate for soil, drainage, and acidity
- Other factors: wind/exposure, temperature extremes, and irrigation needs

**Vines and Ground Covers:**

- Ground preparation: lime and fertilizer preparation
- Use proper seeding rates
- Appropriate soil conditions: drainage, acidity, and slopes
- Generally avoid species requiring irrigation

**Objectives**

- Housekeeping Practices
- Contain Waste
- Minimize Disturbed Areas
- Stabilize Disturbed Areas
- Protect Slopes/Channels
- Control Site Perimeter
- Control Internal Erosion

**Targeted Pollutants**

**H M L**

- Sediment
- Nutrients
- Heavy Metals
- Toxic Materials
- Oil & Grease
- Floatable Materials
- Bacteria & Viruses
- Other Waste

**Implementation Requirements**

**H M L**

- Capital Costs
- O&M Costs
- Maintenance
- Training
- Staffing
- Administrative

H=High M=Medium L=Low



153 North 100 East  
Lehi, UT 84043

# BMP: Surface Roughening

SR

## Objectives

- Housekeeping Practices
- Contain Waste
- Minimize Disturbed Areas
- Stabilize Disturbed Areas
- Protect Slopes/Channels
- Control Site Perimeter
- Control Internal Erosion

## Targeted Pollutants

### H M L

- Sediment
- Nutrients
- Heavy Metals
- Toxic Materials
- Oil & Grease
- Floatable Materials
- Bacteria & Viruses
- Other Waste

## Implementation Requirements

### H M L

- Capital Costs
- O&M Costs
- Maintenance
- Training
- Staffing
- Administrative

H=High M=Medium L=Low



153 North 100 East  
Lehi, UT 84043

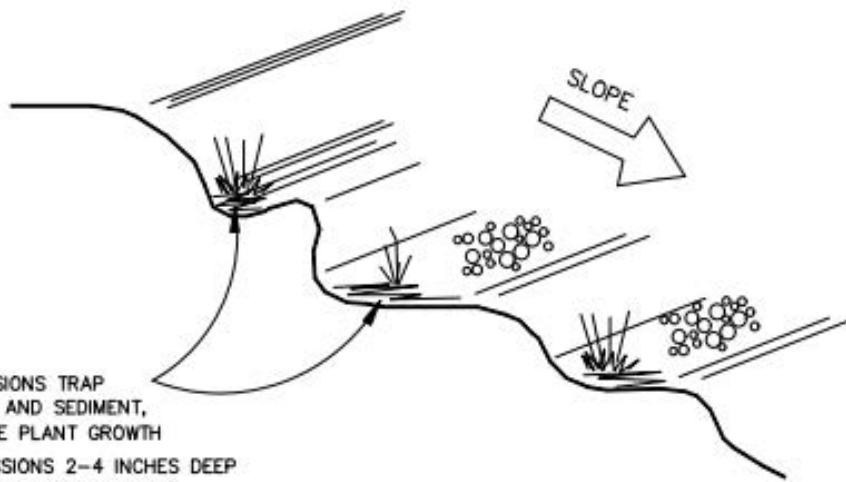

DEPRESSIONS TRAP  
RUNOFF AND SEDIMENT,  
PROMOTE PLANT GROWTH  
(DEPRESSIONS 2-4 INCHES DEEP  
AND 4-6 INCHES APART)

### Description:

Rough preparation of working areas leaving depressions and uneven surfaces. Depressions should be done parallel to contours.

### Application:

Surface roughening is appropriate for all construction that will not be receiving impervious cover within 14 days and that will be exposed less than 60 days (seed areas to be open in excess of 60 days).

### Installation / Application Criteria:

- Surface should be left in rough condition during initial earthwork activity
- Surfaces that have become smoothed or compacted due to equipment traffic should be roughened by use of disks, spring harrows, teeth on front end of loader, or similar, operating along the contours of the slope. Tracking (by crawler tractor driving along slope) may also be used to provide depressions parallel to contours
- Avoid compaction of soils during roughening as this inhibits plant growth and promotes storm water runoff. Limit tracked machinery to sandy soil
- Seed or much areas to be exposed in excess of 60 days
- Employ dust controls (see Dust Control Detail Sheet if appropriate)

### Limitations:

- Will not withstand heavy rainfall
- Slopes steeper than 2:1 (50%) should be benched (see Benching Detail Sheet)

### Maintenance:

- Inspect following any storm event and at a minimum of weekly
- If erosion in the form of rills (small waterways formed by runoff) is evident, perform machine roughening of area
- For vegetated slopes, reseed areas that are bare or have been reworked

# BMP: Sediment Trap

ST

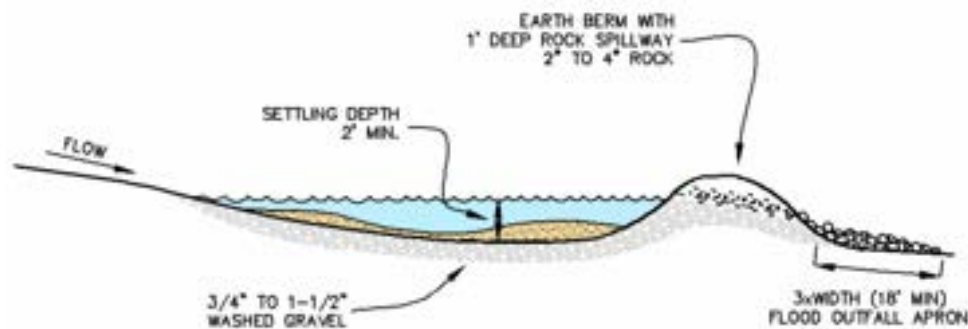

**Description:**

A sediment trap is a small excavated or bermed area where runoff from small drainage areas is detained and sediment can settle.

**Application:**

- Temporary control for runoff from disturbed areas of less than 3 acres
- Temporary control for discharge from diversion dike, surface benching, or other temporary drainage measures

**Installation / Application Criteria:**

- Design basin for site specific location
- Excavate basin or construct compacted berm containment
- Construct outfall spillway with apron
- Provide downstream silt fence if necessary

**Limitations:**

- Should be sized based on anticipated runoff, sediment loading, and drainage area size
- May require silt fence at outlet for entrapment of very fine silts and clays

**Maintenance:**

- Inspect after each rainfall event and at a minimum of once every two weeks
- Repair any damage to berm, spillway, or sidewalls
- Remove accumulated sediment as it reaches 2/3 height of available storage
- Check outlet for sedimentation/erosion of downgradient area and remediate as necessary. Install silt fence if sedimentation is apparent

**Objectives**

- Housekeeping Practices
- Contain Waste
- Minimize Disturbed Areas
- Stabilize Disturbed Areas
- Protect Slopes/Channels
- Control Site Perimeter
- Control Internal Erosion

**Targeted Pollutants**

**H M L**

- Sediment
- Nutrients
- Heavy Metals
- Toxic Materials
- Oil & Grease
- Floatable Materials
- Bacteria & Viruses
- Other Waste

**Implementation Requirements**

**H M L**

- Capital Costs
- O&M Costs
- Maintenance
- Training
- Staffing
- Administrative

H=High M=Medium L=Low



153 North 100 East  
Lehi, UT 84043

# BMP: Temporary Drains and Swales

TDS

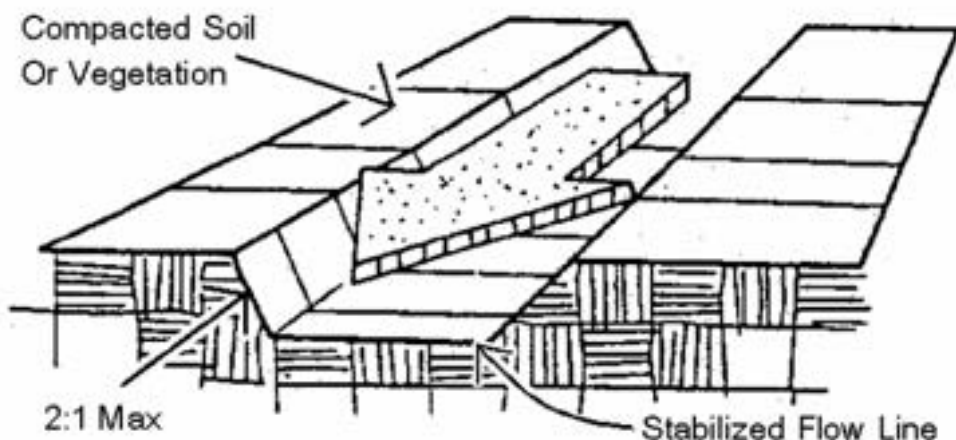

**Description:**

Temporary drains and swales are used to divert off-site runoff around the construction site or divert runoff from stabilized areas around disturbed areas.

**Application:**

- Temporary drains and swales are appropriate for diverting upslope runoff around unstabilized or disturbed areas of the construction site
- Prevent slope failures, prevent damage to adjacent property, prevent erosion and transport of sediments into water ways, increases the potential for infiltration, or divert sediment-laden runoff into sediment basins or traps

**Installation / Application Criteria:**

- Temporary drainage swales will effectively convey runoff and avoid erosion if built properly
- Size temporary drainage swales using local drainage design criteria. A permanent drainage channel must be designed by a professional engineer (see the local drainage design criteria for proper design)
- At a minimum, the drain/swale should conform to predevelopment drainage patterns and capacities
- Construct the drain/swale with an uninterrupted positive grade to a stabilized outlet. Provide erosion protection or energy dissipation measures if the flow out of the drain or swale can reach an erosive velocity

**Limitations:**

- Temporary drains and swales or any other diversion of runoff should not adversely impact upstream or downstream properties
- Temporary drains and swales must conform to local floodplain management requirements

**Maintenance:**

- Inspect weekly and after each rainfall event
- Repair any erosion immediately
- Remove any sediment that builds up in the swale and restricts its flow capacity

**Objectives**

- Housekeeping Practices
- Contain Waste
- Minimize Disturbed Areas
- Stabilize Disturbed Areas
- Protect Slopes/Channels
- Control Site Perimeter
- Control Internal Erosion

**Targeted Pollutants**

**H M L**

- Sediment
- Nutrients
- Heavy Metals
- Toxic Materials
- Oil & Grease
- Floatable Materials
- Bacteria & Viruses
- Other Waste

**Implementation Requirements**

**H M L**

- Capital Costs
- O&M Costs
- Maintenance
- Training
- Staffing
- Administrative

H=High M=Medium L=Low



153 North 100 East  
Lehi, UT 84043

# BMP: Temporary and Permanent Seeding

TPS

## Objectives

- Housekeeping Practices
- Contain Waste
- Minimize Disturbed Areas
- Stabilize Disturbed Areas
- Protect Slopes/Channels
- Control Site Perimeter
- Control Internal Erosion

## Targeted Pollutants

### H M L

- Sediment
- Nutrients
- Heavy Metals
- Toxic Materials
- Oil & Grease
- Floatable Materials
- Bacteria & Viruses
- Other Waste

## Implementation Requirements

### H M L

- Capital Costs
- O&M Costs
- Maintenance
- Training
- Staffing
- Administrative

H=High M=Medium L=Low



153 North 100 East  
Lehi, UT 84043



### Description:

Temporary seeding/establishment of short-term cover by application of rapidly germinating seed mix (alternatively hydroseeding may be utilized). Permanent seeding/establishment of final term cover by application of perennial seed mix (alternatively sod may be utilized).

### Application:

Disturbed areas that are at final grade and which will not be disturbed by continuing activities on site. Alo areas that are not at final grade, but which will be left untouched in excess of one year.

### Recommended Seed Mix:

The recommended seed mix will be dependent on site specific information such as elevation, exposure, soils, water available and topography. Check with the County Extension Service for recommended mixes for site specific conditions:

Utah State University Extension Service  
28 E. State Street (Room 20D)  
Farmington, Utah 84025  
Phone: (801) 451-3412

### Limitations:

- Limited to areas that will not be subject to traffic or high usage
- May require irrigation and fertilizer which creates potential for impacting runoff quality
- May only be applied during appropriate planting season, temporary cover is required until that time

### Installation:

- Roughen soil to a depth of 2 inches. Add fertilizer, manure, or topsoil as necessary
- Evenly distribute seed using a commonly accepted method such as; breast seeding, drilling, hydroseeding
- Use a seed mix appropriate for soil and location that will provide rapid germination and growth. Check with County for recommended mix and application rate.
- Cover area with mulch if required due to steep slopes or unsuitable weather conditions

### Maintenance:

- Provide irrigation as required to establish growth and to maintain plant cover through duration of project
- Reseed as necessary to provide 75% coverage
- Remediate any areas damaged by erosion or traffic
- When 75% coverage is achieved, inspect monthly for damage and remediate as necessary

# BMP: Temporary Stream Crossing

TSC

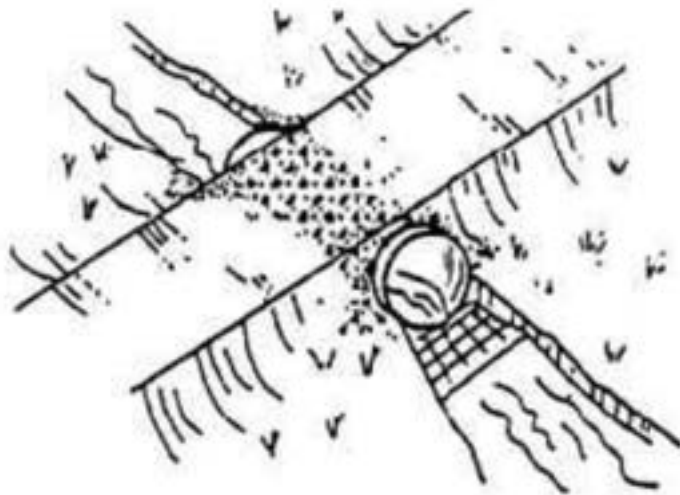

**Description:**

A temporary access stream crossing is a temporary culvert, ford, or bridge placed across a waterway to provide access for construction purposes for a period of less than one year. Temporary access crossings are not intended to be used to maintain traffic for the general public.

**Application:**

Temporary stream crossings should be installed at all designated crossings of perennial and intermittent streams on the construction site, as well as for dry channels which may be significantly eroded by construction traffic.

**Installation / Application Criteria:**

Requires knowledge of stream flows and soil strength and should be designed under the direction of a Utah registered engineer with knowledge of both hydraulics and construction loading requirements for structures.

**Limitations:**

- May be expensive for a temporary improvement
- Requires other BMPs to minimize soil disturbance during installation and removal
- Fords should only be used in dry weather
- A stream alteration permit may be required, contact the Utah Division of Water Rights before implementation

**Maintenance:**

- Inspect weekly and after each significant rainfall, including assessment of foundations
- Periodically remove silt from crossings
- Replace lost aggregate from inlets and outlets of culverts

**Objectives**

- Housekeeping Practices
- Contain Waste
- Minimize Disturbed Areas
- Stabilize Disturbed Areas
- Protect Slopes/Channels
- Control Site Perimeter
- Control Internal Erosion

**Targeted Pollutants**

**H M L**

- Sediment
- Nutrients
- Heavy Metals
- Toxic Materials
- Oil & Grease
- Floatable Materials
- Bacteria & Viruses
- Other Waste

**Implementation Requirements**

**H M L**

- Capital Costs
- O&M Costs
- Maintenance
- Training
- Staffing
- Administrative

H=High M=Medium L=Low



153 North 100 East  
Lehi, UT 84043

# BMP: Vehicle and Equipment Cleaning

VEC



## Objectives

- Housekeeping Practices
- Contain Waste
- Minimize Disturbed Areas
- Stabilize Disturbed Areas
- Protect Slopes/Channels
- Control Site Perimeter
- Control Internal Erosion

## Targeted Pollutants

### H M L

- Sediment
- Nutrients
- Heavy Metals
- Toxic Materials
- Oil & Grease
- Floatable Materials
- Bacteria & Viruses
- Other Waste

## Implementation Requirements

### H M L

- Capital Costs
- O&M Costs
- Maintenance
- Training
- Staffing
- Administrative

H=High M=Medium L=Low



153 North 100 East  
Lehi, UT 84043

## Description:

Prevent or reduce the discharge of pollutants to storm water from vehicle and equipment cleaning by using off-site facilities, washing in designated and contained areas only, eliminating discharges to the storm drain by infiltrating or recycling the wash water, and/or training employees and subcontractors.

## Installation / Application Criteria:

- Use off-site commercial washing businesses as much as possible. Washing vehicles and equipment outdoors or in areas where wash water flows onto paved surfaces or into drainage pathways can pollute storm water. If you wash large numbers of vehicles or pieces of equipment, consider conducting this work at an off-site commercial business. These businesses are better equipped to handle and dispose of the wash waters properly. Performing this work off-site can also be economical by eliminating the need for a separate washing operation at your site.
- If washing must occur on-site, use designated, bermed wash areas to prevent wash water contact with storm water, creeks, rivers, and other water bodies. The wash area can be sloped for wash water collection and subsequent infiltration into the ground.
- Use as little water as possible to avoid having to install erosion and sediment controls for the wash area. Use phosphate-free biodegradable soaps. Educate employees and subcontractors on pollution prevention measures. Do not permit steam cleaning on-site. Steam cleaning can generate significant pollutant concentrations.

## Limitations:

- Even phosphate-free, biodegradable soaps have been shown to be toxic to fish before the soap degrades
- Sending vehicles/equipment off-site should be done in conjunction with Stabilized Construction Entrance

## Maintenance:

- Minimal, some berm repair may be necessary

# BMP: Vehicle and Equipment Fueling

VEF

## Objectives

- Housekeeping Practices
- Contain Waste
- Minimize Disturbed Areas
- Stabilize Disturbed Areas
- Protect Slopes/Channels
- Control Site Perimeter
- Control Internal Erosion

## Targeted Pollutants

### H M L

- Sediment
- Nutrients
- Heavy Metals
- Toxic Materials
- Oil & Grease
- Floatable Materials
- Bacteria & Viruses
- Other Waste

## Implementation Requirements

### H M L

- Capital Costs
- O&M Costs
- Maintenance
- Training
- Staffing
- Administrative

H=High M=Medium L=Low



153 North 100 East  
Lehi, UT 84043

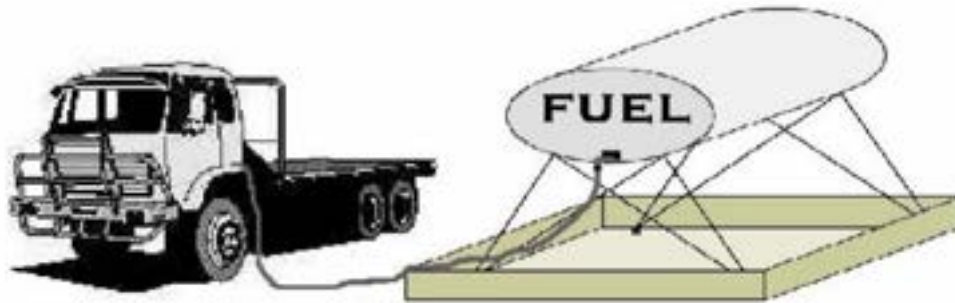

### Description:

Prevent fuel spills and leaks and reduce their impacts to storm water by using offsite facilities, fueling in designated areas only, enclosing or covering stored fuel, implementing spill controls, and training employees and subcontractors.

### Installation / Application Criteria:

- Use off-site fueling stations as much as possible. Fueling vehicles and equipment outdoors or in areas where fuel may spill/leak onto paved surfaces or into drainage pathways can pollute storm water. If you fuel a large number of vehicles or pieces of equipment, consider using an off-site fueling station. These businesses are better equipped to handle fuel and spills properly. Performing this work off-site can also be economical by eliminating the need for a separate fueling area at your site.
- If fueling must occur on-site, use designated areas, located away from drainage courses, to prevent the run on of storm water and the runoff of spills. Discourage "topping-off" of fuel tanks.
- Always use secondary containment, such as a drain pan or drop cloth, when fueling to catch spills/leaks. Place a stockpile of spill cleanup materials where it will be readily accessible. Use adsorbent materials on small spills rather than hosing down or burying the spill. Remove the adsorbent materials promptly and dispose of properly.
- Carry out all Federal and State requirements regarding stationary above ground storage tanks. (40 CF Sub. J) Avoid mobile fueling of mobile construction equipment around the site; rather, transport the equipment to designated fueling area. With the exception of tracked equipment such as bulldozers and perhaps forklifts, most vehicles should be able to travel to a designated area with little lost time. Train employees and subcontractors in proper fueling and cleanup procedures.

### Limitations:

Sending vehicles/equipment off-site should be done in conjunction with Stabilized Construction Entrance.

### Maintenance:

- Keep ample supplies of spill cleanup materials on-site
- Inspect fueling areas and storage tanks on a regular schedule

# BMP: Waste Disposal

WD

## Objectives

- Housekeeping Practices
- Contain Waste
- Minimize Disturbed Areas
- Stabilize Disturbed Areas
- Protect Slopes/Channels
- Control Site Perimeter
- Control Internal Erosion

## Targeted Pollutants

### H M L

- Sediment
- Nutrients
- Heavy Metals
- Toxic Materials
- Oil & Grease
- Floatable Materials
- Bacteria & Viruses
- Other Waste

## Implementation Requirements

### H M L

- Capital Costs
- O&M Costs
- Maintenance
- Training
- Staffing
- Administrative

H=High M=Medium L=Low



153 North 100 East  
Lehi, UT 84043

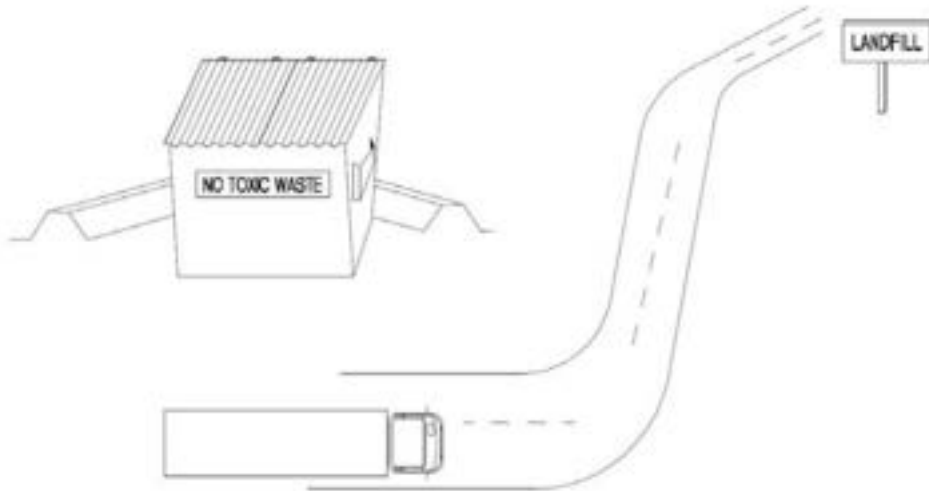

### Description:

Controlled storage and disposal of solid waste generated by construction activities.

### Application:

All construction sites.

### Installation / Application Criteria:

- Designate one or several waste collection areas with easy access for construction vehicles and personnel. Ensure no waterways or storm drainage inlets are located near the waste collection areas
- Construct compacted earthen berm (See Earth Berm Barrier Information Sheet), or similar perimeter containment around collection area for impoundment in the case of spills
- Ensure all on site personnel are aware of and utilize designated waste collection area properly and for intended use only (e.g. all toxic, hazardous, or recyclable materials shall be properly disposed of separately from general construction waste)
- Arrange for periodic pickup, transfer and disposal of collected waste at an authorized disposal location. Include regular portable toilet service is water management activities.

### Limitations:

On-site personnel are responsible for correct disposal of waste.

### Maintenance:

- Discuss waste management procedures at progress meetings
- Collect site trash daily and deposit in containers at designated collection areas
- Randomly check disposed materials for any unauthorized waste (e.g., toxic materials).