

LEHI CITY STANDARD DETAIL	
<b>STREET INTERSECTION &amp; UTILITY LOCATION</b>	
<b>RD-01</b>	DATE: JANUARY 2022

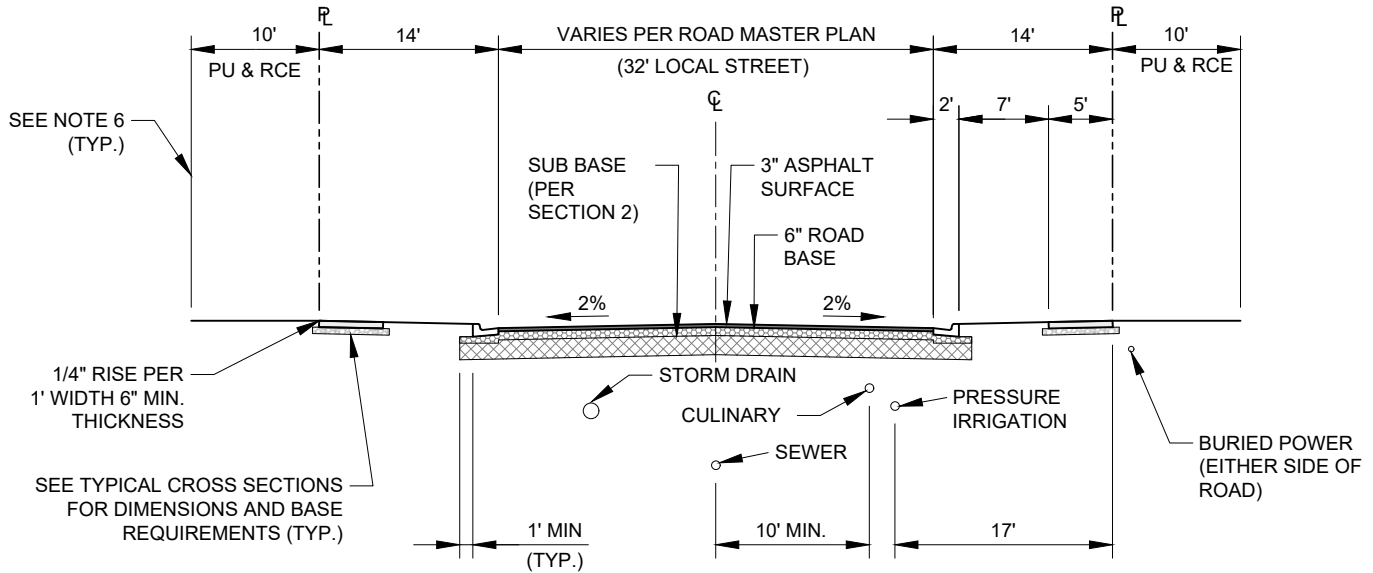

### STANDARD STREET SECTION

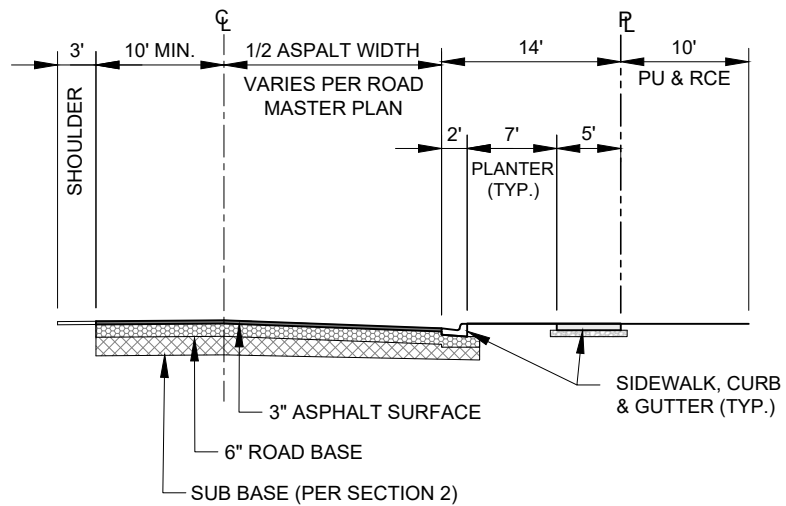

### HALF WIDTH STREET SECTION

**NOTES:**

1. VARIANCES TO THE UTILITY LOCATIONS OR CROSS SECTION SHOWN MUST BE APPROVED BY LEHI CITY.
2. SLOPE EASEMENTS REQUIRED FOR CUT OR FILL SLOPES WHICH EXTEND OUTSIDE RIGHT-OF-WAY.
3. SELECT GRAVEL SUBBASE AS REQUIRED BY SECTION 2.
4. FIRE HYDRANTS, BLOWOFFS, MAIL BOXES, ETC. MUST BE PLACED IN PLANTER STRIP OR FOR ROADWAYS WITHOUT PLANTERS, THESE ITEMS MUST BE PLACED BEHIND BACK OF SIDEWALK AS PER APPROPRIATE STANDARD DETAILS.
5. CURB AND SIDEWALK SHALL REMAIN UNOBSTRUCTED.
6. PUBLIC UTILITY AND ROADWAY CONSTRUCTION EASEMENT (PU & RCE).
7. REQUIREMENTS FOR SIDEWALK MAY BE WAIVED FOR DEVELOPMENTS WITHIN LIGHT INDUSTRIAL OR INDUSTRIAL ZONING DISTRICTS OR WITHIN NON-RESENTIAL P.U.D.'S AS DEEMED APPROPRIATE BY THE DEVELOPMENT REVIEW COMMITTEE AND PLANNING COMMISSION.



LEHI CITY STANDARD DETAIL

### STANDARD STREET CROSS SECTION & UTILITY LOCATIONS

**RD-02**

DATE: MAY 2024

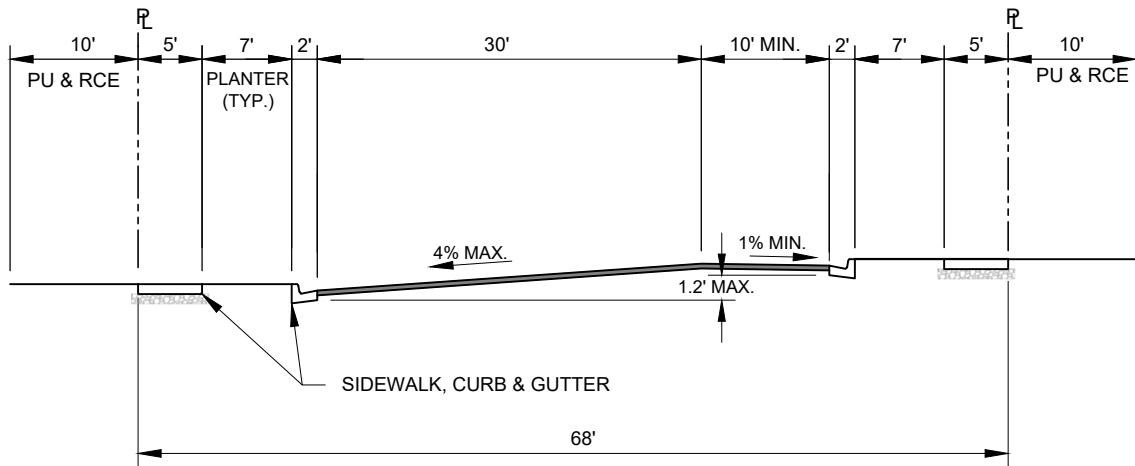

**COLLECTOR ROAD**

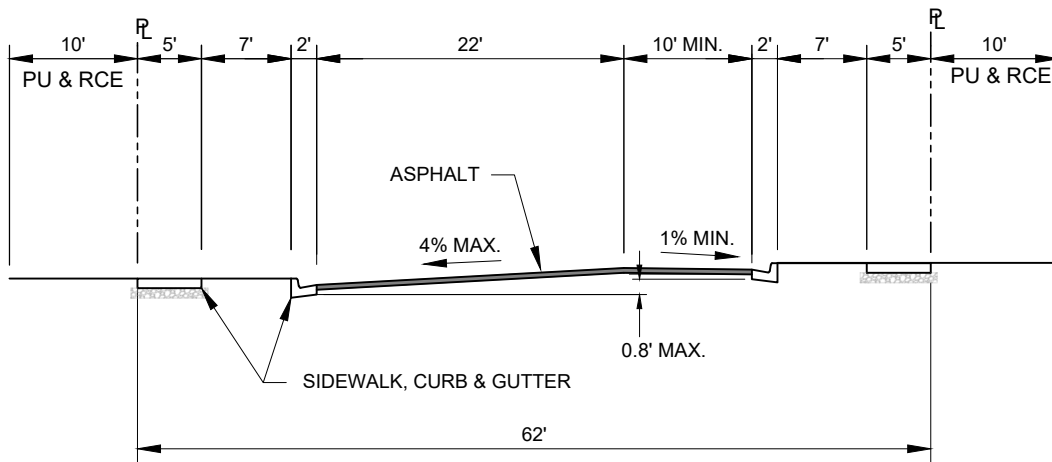

**MINOR STREET**



LEHI CITY STANDARD DETAIL

**CURBS AT UNEQUAL ELEVATIONS**

**RD-03**

DATE:  
MAY 2024

NOTES:

1. THE USE OF THESE CROSS SECTIONS IS SUBJECT TO THE APPROVAL OF THE CITY ENGINEER.
2. PUBLIC UTILITY AND ROADWAY CONSTRUCTION EASEMENT (PU & RCE).

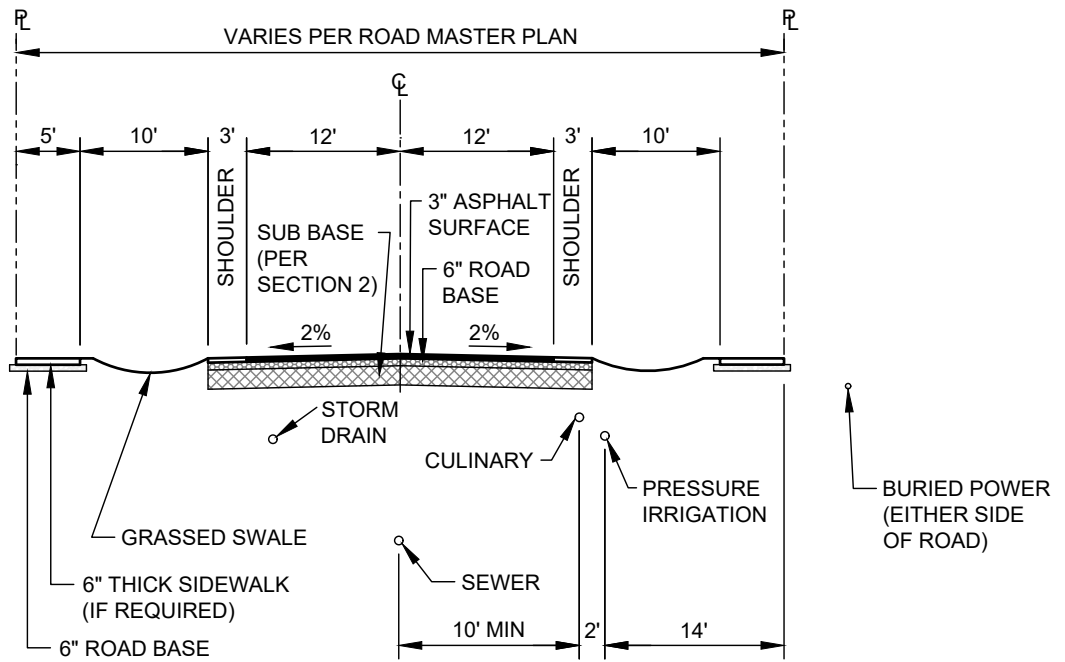

**RURAL STREET SECTION**



LEHI CITY STANDARD DETAIL

**RURAL STREET CROSS SECTION AND UTILITY LOCATIONS**

**RD-04**

DATE:  
JANUARY 2022

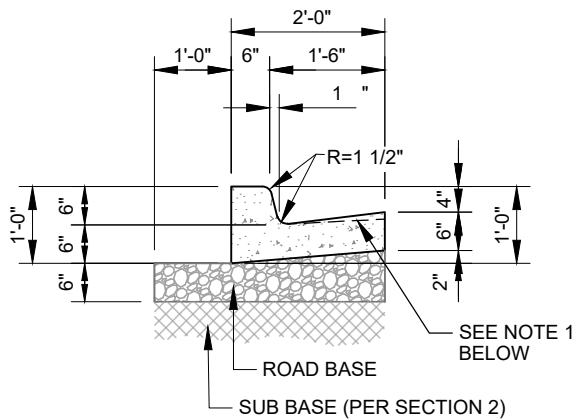

- NOTES:
1. PAN OF GUTTER SHALL BE FLATTENED TO A 5% MAX. GRADE WITHIN "CLEAR SPACE" OF ADA RAMPS

### HIGH BACK CURB & GUTTER

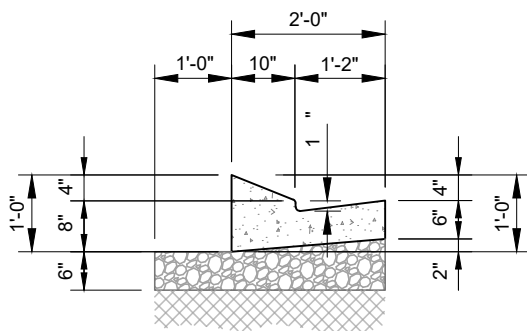

- NOTES:
1. THIS CROSS SECTION IS ONLY FOR COMMERCIAL, INDUSTRIAL ZONES AND TEMPORARY TURNAROUNDS.
  2. THE USE OF THIS CROSS SECTION IS SUBJECT TO APPROVAL OF THE CITY ENGINEER

### MODIFIED CURB & GUTTER (MOUNTABLE TYPE)

- NOTES:
1. PLACE EXPANSION JOINTS (JOINT FILLER MATERIAL) EVERY 50' ALONG CURB, GUTTER & SIDEWALK SECTIONS. JOINTS TO BE PLACED THE FULL DEPTH OF CONCRETE PLUS 1", FLUSH WITH TOP OF CONCRETE.
  2. CONTRACTION JOINTS ALONG CURB & GUTTER SECTIONS SHOULD BE PLACED AT INTERVALS NOT TO EXCEED 10'.
  3. CONTRACTION JOINTS ALONG SIDEWALK SECTIONS SHOULD BE PLACED AT INTERVALS MATCHING THE SIDEWALK WIDTH, EXCEPT WITH VERY WIDE CONCRETE SECTIONS WHERE CONTRACTION JOINT SPACING SHALL NOT EXCEED 2 TIMES THE SLAB THICKNESS IN FEET. FOR EXAMPLE THE MAXIMUM JOINT SPACING FOR A 4" THICK CONCRETE SLAB WOULD BE 8 FEET.
  4. WHEN CURB, GUTTER OR SIDEWALK MUST BE REMOVED & REPLACED, FOLLOW WRITTEN GUIDELINES IN SECTION 5.

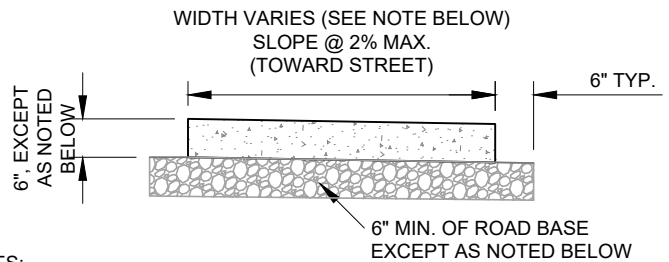

- NOTES:
1. 5' SIDEWALK WIDTH WHEN USED IN CONJUNCTION WITH PLANTER.  
5' SIDEWALK WIDTH AGAINST CURB & GUTTER.  
6' SIDEWALK WIDTH WHEN USED AGAINST A CURB & GUTTER WITHIN A PARKING LOT.
  2. SIDEWALK THICKNESS MAY BE 5" AND ROAD BASE THICKNESS 4" OUTSIDE OF SUBDIVISIONS IN AREA WITH NO ACCESSES AS APPROVED BY THE REVIEWING DEPARTMENTS.

### SIDEWALK

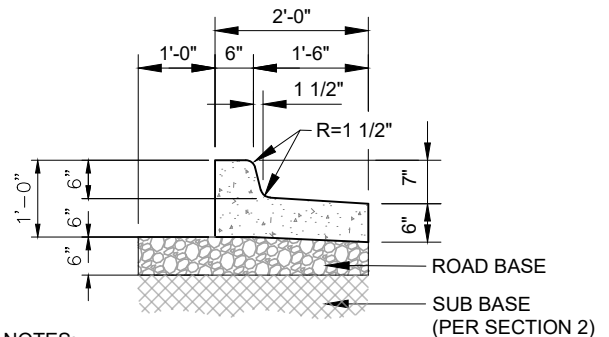

- NOTES:
1. THE USE OF THIS CROSS SECTION IS SUBJECT TO APPROVAL OF THE CITY ENGINEER

### REVERSE SLOPE CURB & GUTTER

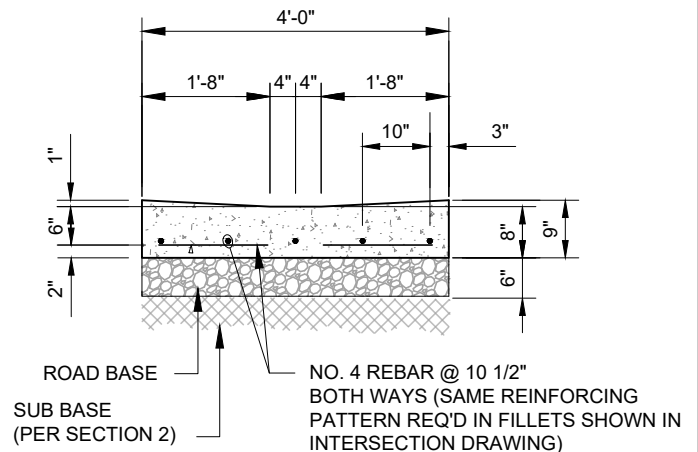

### 4' DRAIN GUTTER



LEHI CITY STANDARD DETAIL

### CURB, GUTTER AND SIDEWALK

RD-05

DATE:  
JUNE 2024

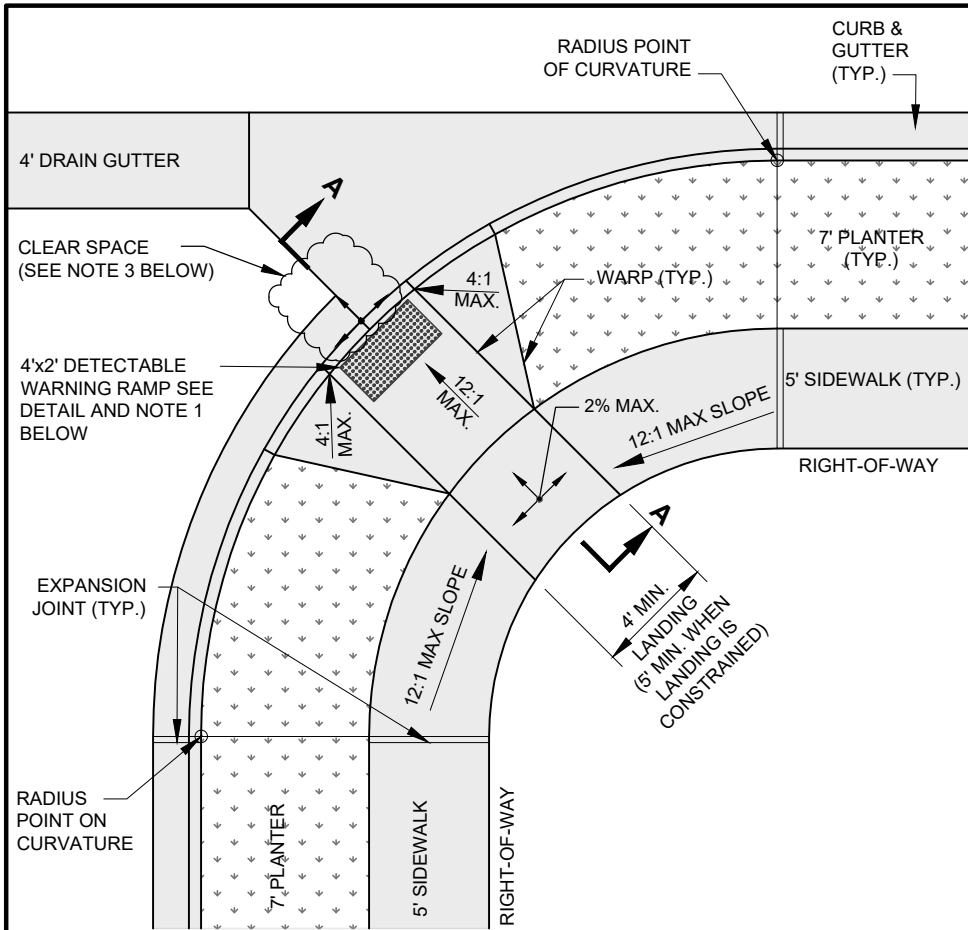

**PLAN VIEW**

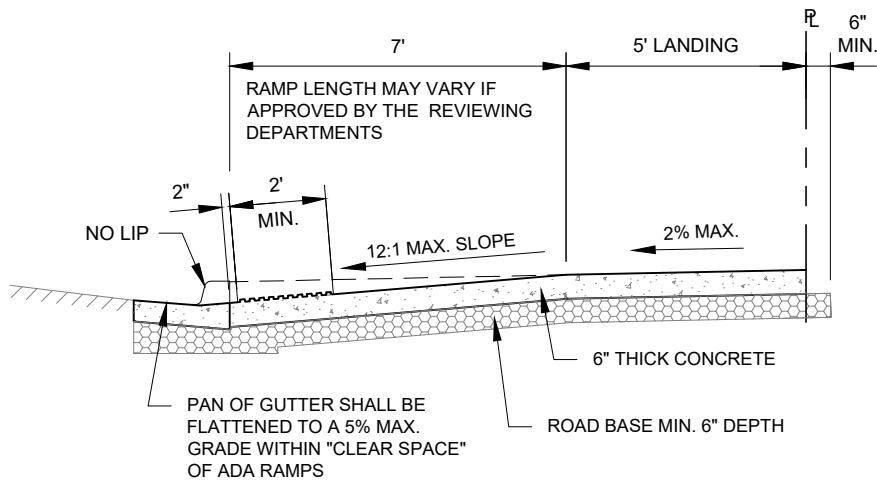

**SECTION A-A**

**GENERAL NOTES:**

1. ROAD/FIELD GRADES MAY REQUIRE ADJUSTMENT AS PER APPROVAL BY PUBLIC WORKS DEPARTMENT
2. DETECTABLE WARNING SURFACES SHALL EXTEND (24 IN) MINIMUM IN THE DIRECTION OF TRAVEL AND THE FULL WIDTH OF THE CURB RAMP (EXCLUSIVE OF FLARES), THE LANDING, OR THE BLENDED TRANSITION.
3. 4'x4' MIN. CLEAR SPACE REQUIRED.
  - a. MAX. 5% GRADE ALONG RUNNING SLOPE.
  - b. CROSS SLOPE WITHIN CLEAR SPACE
    - i. MAX. 2% GRADE WHEN EITHER LEG OF INTERSECTION IS STOP CONTROLLED
    - ii. MAX. 5% GRADE WHEN INTERSECTION IS UNCONTROLLED OR SIGNAL CONTROLLED
4. PEDESTRIAN BUTTON (OR RELATED APPURTENANCES) SHALL BE 40" - 44" ABOVE LANDING AND A MAXIMUM OF 10" FROM THE LANDING.

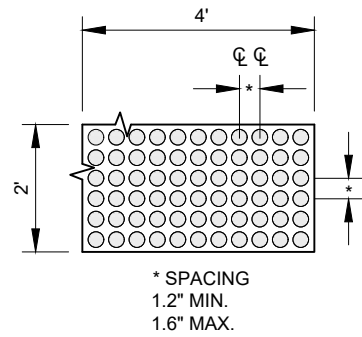

**DETECTABLE RAMP DETAIL**

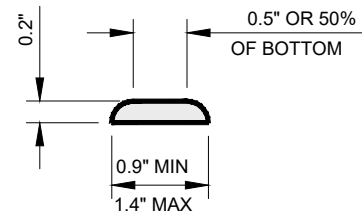

**RAISED TRUNCATED DOME DETAIL**

PUBLIC WORKS DEPARTMENT MUST APPROVE TYPES AND COLOR OF DETECTABLE WARNING DEVICES USED.

**DETECTABLE WARNING DETAILS**

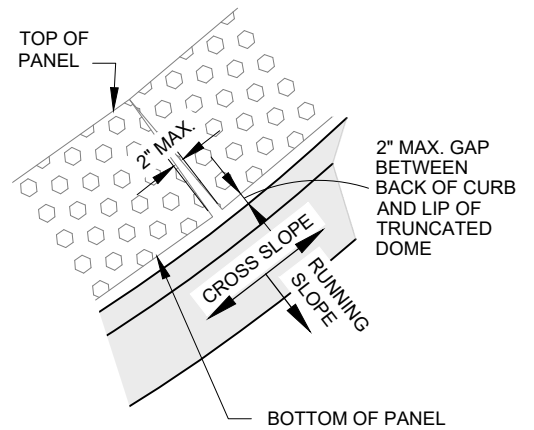

**DETECTABLE WARNING SURFACE PANEL GAP DETAIL**



LEHI CITY STANDARD DETAIL

**ADA RAMP  
PLANTER STRIP  
(AT INTERSECTION)**

**RD-06**

DATE:  
JUNE 2024

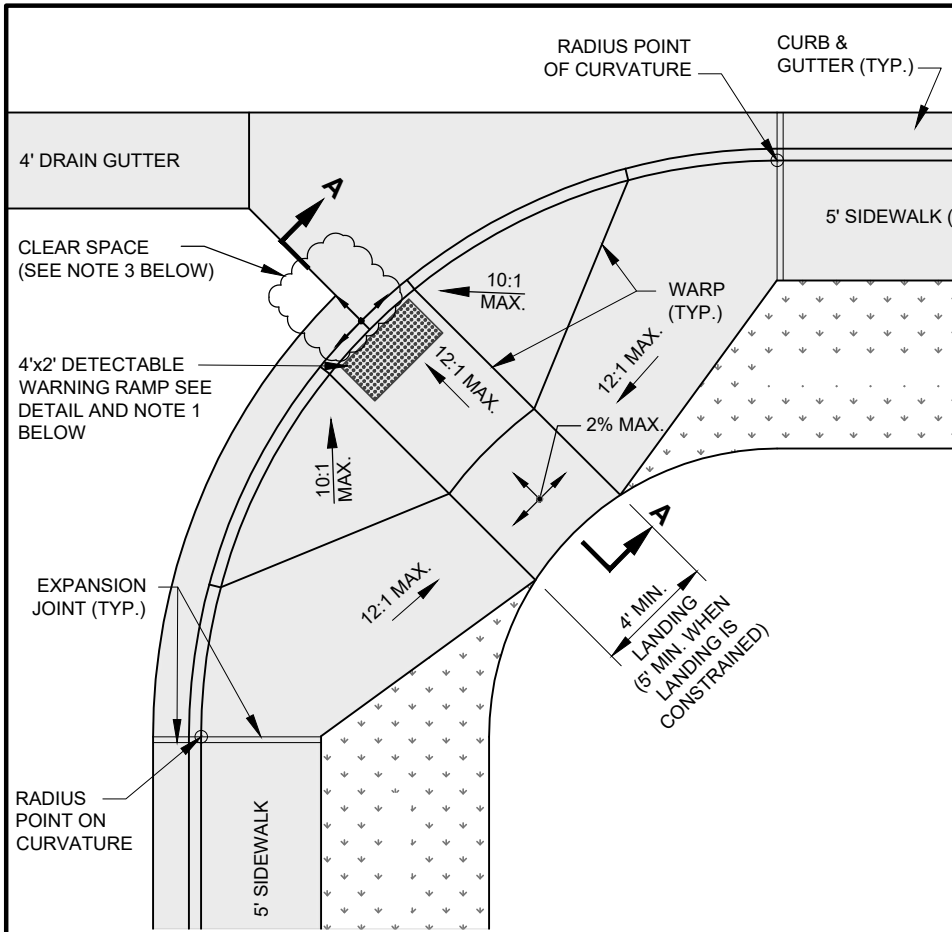

**PLAN VIEW**

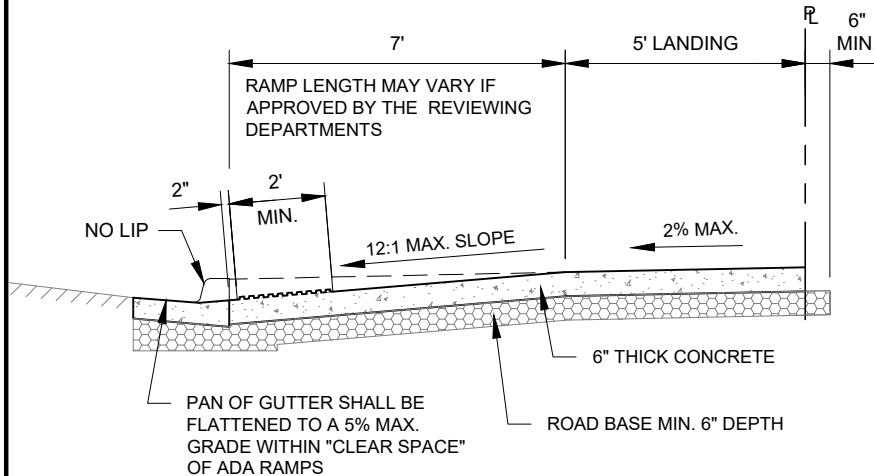

**SECTION A-A**

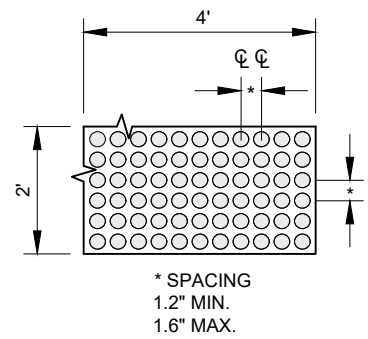

**DETECTABLE RAMP DETAIL**

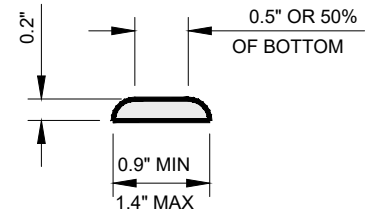

**RAISED TRUNCATED DOME DETAIL**

PUBLIC WORKS DEPARTMENT MUST APPROVE TYPES AND COLOR OF DETECTABLE WARNING DEVICES USED.

**DETECTABLE WARNING DETAILS**

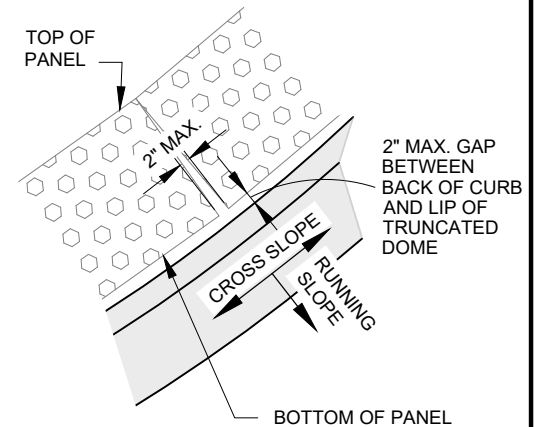

**DETECTABLE WARNING SURFACE PANEL GAP DETAIL**

**GENERAL NOTES:**

1. ROAD/FIELD GRADES MAY REQUIRE ADJUSTMENT AS PER APPROVAL BY PUBLIC WORKS DEPARTMENT
2. DETECTABLE WARNING SURFACES SHALL EXTEND (24 IN) MINIMUM IN THE DIRECTION OF TRAVEL AND THE FULL WIDTH OF THE CURB RAMP (EXCLUSIVE OF FLARES), THE LANDING, OR THE BLENDED TRANSITION.
3. 4'x4' MIN. CLEAR SPACE REQUIRED.
  - a. MAX. 5% GRADE ALONG RUNNING SLOPE.
  - b. CROSS SLOPE WITHIN CLEAR SPACE
    - i. MAX. 2% GRADE WHEN EITHER LEG OF INTERSECTION IS STOP CONTROLLED
    - ii. MAX. 5% GRADE WHEN INTERSECTION IS UNCONTROLLED OR SIGNAL CONTROLLED
4. PEDESTRIAN BUTTON (OR RELATED APPURTENANCES) SHALL BE 40" - 44" ABOVE LANDING AND A MAXIMUM OF 10" FROM THE LANDING.



LEHI CITY STANDARD DETAIL

**ADA RAMP COMBINATION CURB, GUTTER & SIDEWALK (AT INTERSECTION)**

**RD-07**

DATE: JUNE 2024

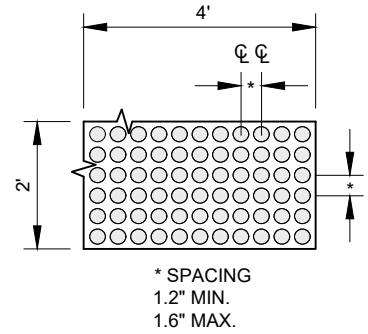
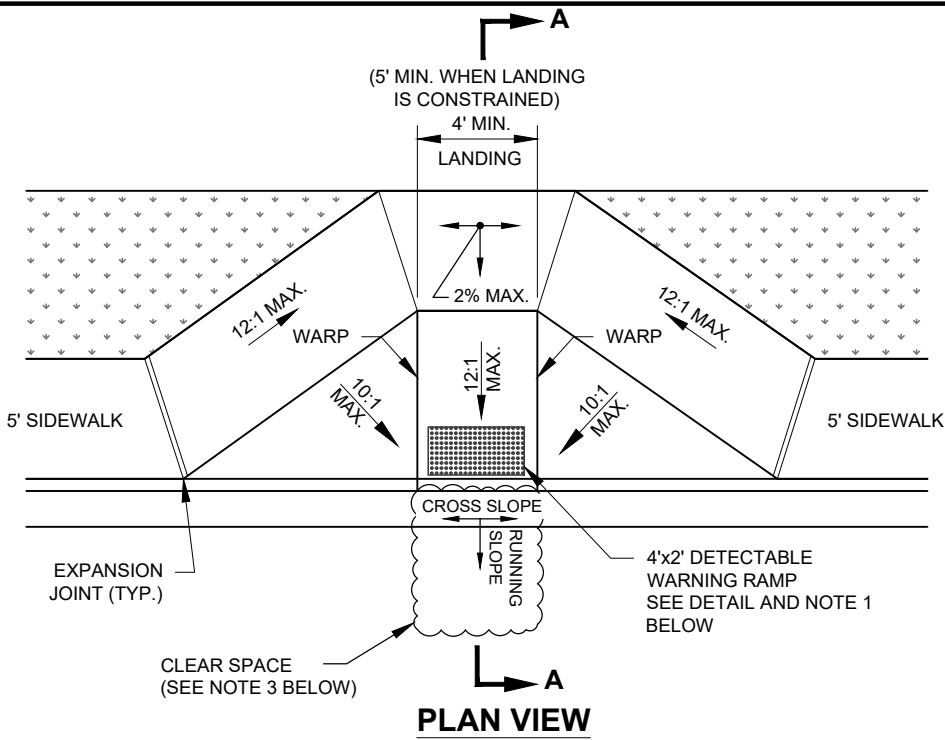

**DETECTABLE RAMP DETAIL**

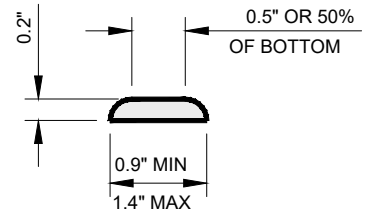

PUBLIC WORKS DEPARTMENT MUST APPROVE TYPES AND COLOR OF DETECTABLE WARNING DEVICES USED.

**DETECTABLE WARNING DETAILS**

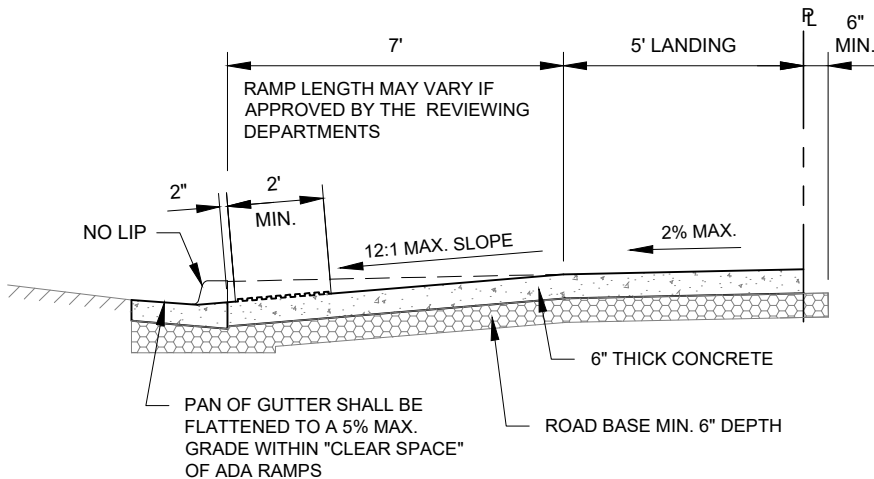

**SECTION A-A**

**GENERAL NOTES:**

1. ROAD/FIELD GRADES MAY REQUIRE ADJUSTMENT AS PER APPROVAL BY PUBLIC WORKS DEPARTMENT
2. DETECTABLE WARNING SURFACES SHALL EXTEND (24 IN) MINIMUM IN THE DIRECTION OF TRAVEL AND THE FULL WIDTH OF THE CURB RAMP (EXCLUSIVE OF FLARES), THE LANDING, OR THE BLENDED TRANSITION.
3. 4'x4' MIN. CLEAR SPACE REQUIRED.
  - a. MAX. 5% GRADE ALONG RUNNING SLOPE.
  - b. CROSS SLOPE WITHIN CLEAR SPACE
    - i. MAX. 2% GRADE WHEN EITHER LEG OF INTERSECTION IS STOP CONTROLLED
    - ii. MAX. 5% GRADE WHEN INTERSECTION IS UNCONTROLLED OR SIGNAL CONTROLLED
4. PEDESTRIAN BUTTON (OR RELATED APPURTENANCES) SHALL BE 40" - 44" ABOVE LANDING AND A MAXIMUM OF 10" FROM THE LANDING.



LEHI CITY STANDARD DETAIL

**ADA RAMP COMBINATION  
CURB, GUTTER & SIDEWALK  
(MID BLOCK)**

**RD-08**

DATE:  
JUNE 2024

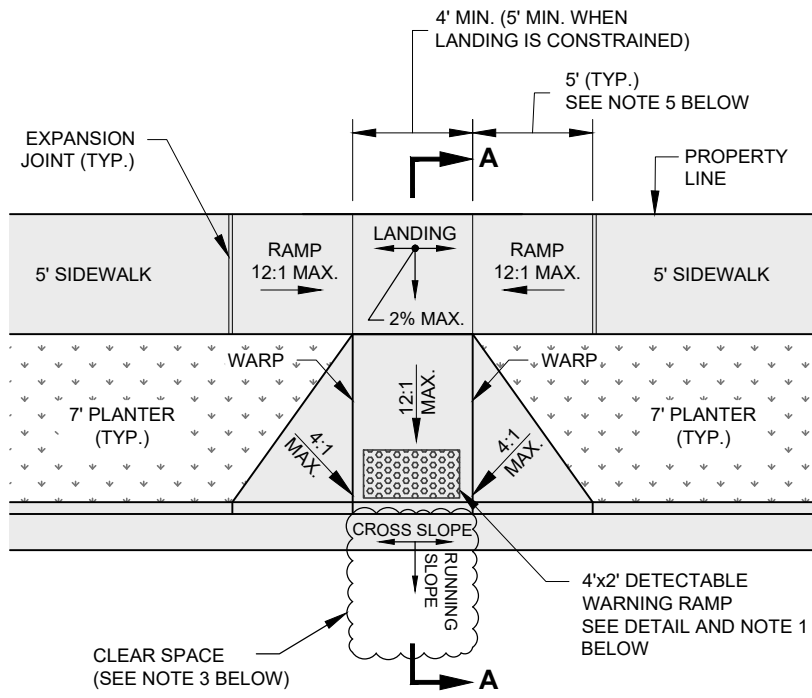

**PLAN VIEW**

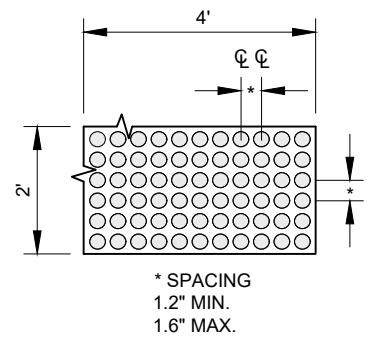

**DETECTABLE RAMP DETAIL**

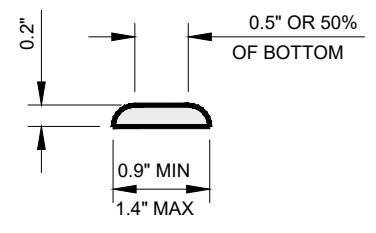

PUBLIC WORKS DEPARTMENT MUST APPROVE TYPES AND COLOR OF DETECTABLE WARNING DEVICES USED.

**DETECTABLE WARNING DETAILS**

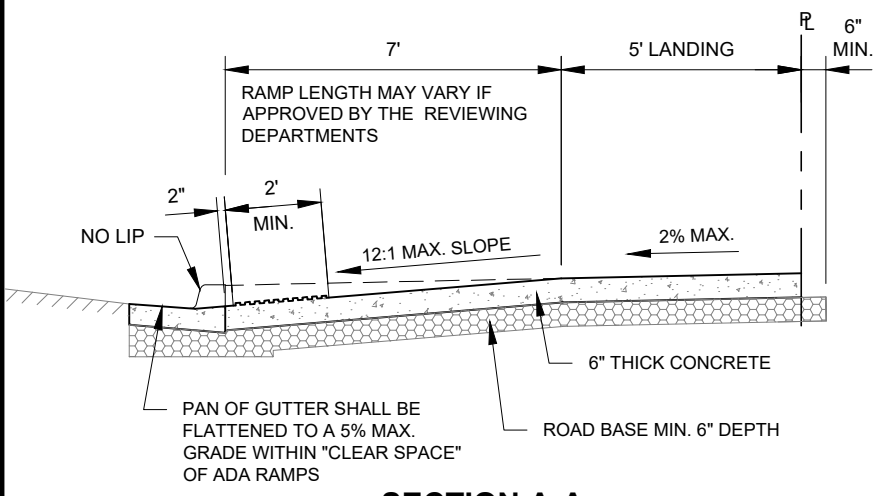

**SECTION A-A**

**GENERAL NOTES:**

1. ROAD/FIELD GRADES MAY REQUIRE ADJUSTMENT AS PER APPROVAL BY PUBLIC WORKS DEPARTMENT
2. DETECTABLE WARNING SURFACES SHALL EXTEND (24 IN) MINIMUM IN THE DIRECTION OF TRAVEL AND THE FULL WIDTH OF THE CURB RAMP (EXCLUSIVE OF FLARES), THE LANDING, OR THE BLENDED TRANSITION.
3. 4'x4' MIN. CLEAR SPACE REQUIRED.
  - a. MAX. 5% GRADE ALONG RUNNING SLOPE.
  - b. CROSS SLOPE WITHIN CLEAR SPACE
    - i. MAX. 2% GRADE WHEN EITHER LEG OF INTERSECTION IS STOP CONTROLLED
    - ii. MAX. 5% GRADE WHEN INTERSECTION IS UNCONTROLLED OR SIGNAL CONTROLLED
4. PEDESTRIAN BUTTON (OR RELATED APPURTENANCES) SHALL BE 40" - 44" ABOVE LANDING AND A MAXIMUM OF 10" FROM THE LANDING.
5. WHEN SIDEWALK GRADE EXCEEDS 12:1 (8.33%), SIDEWALK RAMP LENGTH SHALL BE 15' MIN.



LEHI CITY STANDARD DETAIL	
<b>ADA RAMP PLANTER STRIP (MID BLOCK)</b>	
<b>RD-09</b>	DATE: JUNE 2024

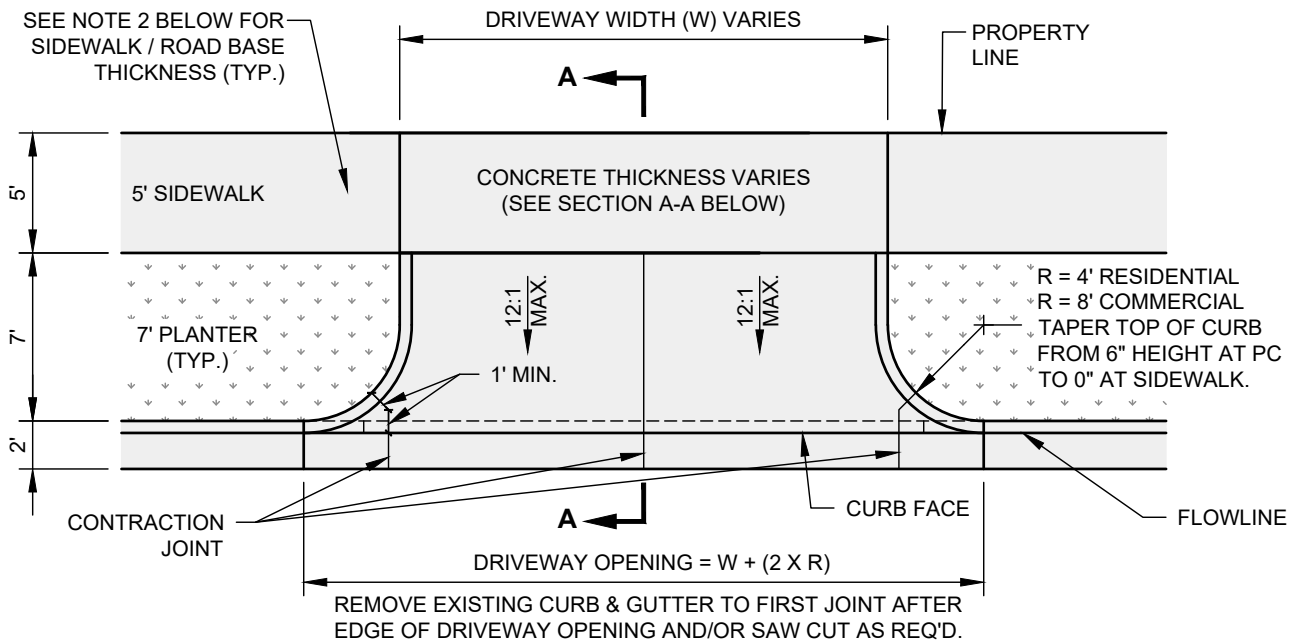

**PLAN VIEW**

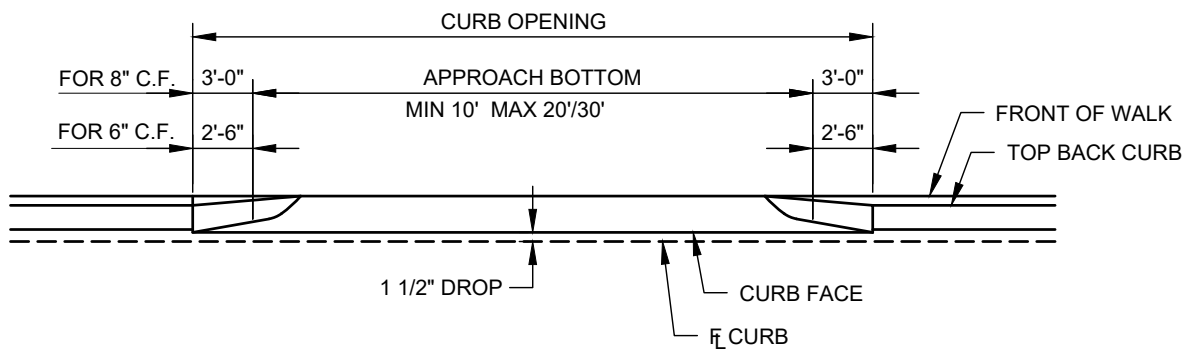

**ELEVATION VIEW**

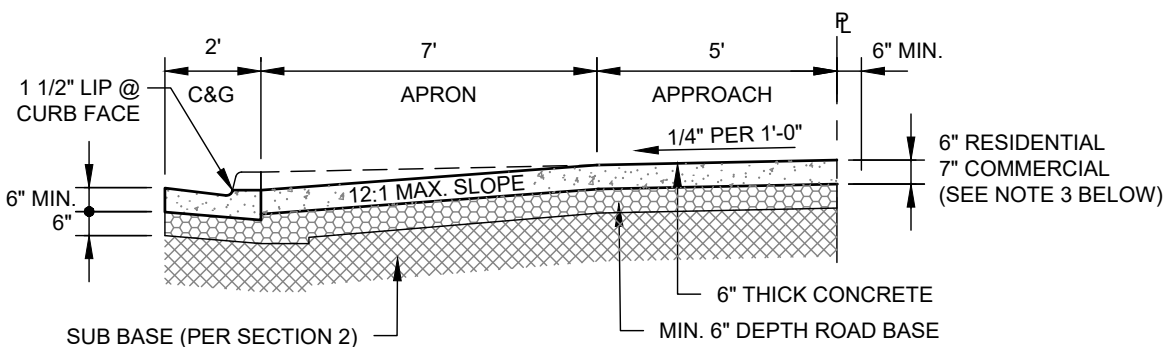

**SECTION A-A**

**GENERAL NOTES:**

1. ALL PROPOSED DRIVEWAY PLACEMENTS SHALL BE INSPECTED BY THE LEHI CITY STREET DEPARTMENT PRIOR TO POURING OF CONCRETE.
2. IN THE EVENT THAT SIDEWALKS ARE INSTALLED PRIOR TO THE INSTALLATION OF DRIVE APPROACHES, AND THEY ARE NOT CONSTRUCTED TO MEET THE STANDARDS ABOVE, ALL NON-COMPLIANT SIDEWALK SECTIONS SHALL BE REMOVED & REPLACED AS PART OF THE DRIVE APPROACH CONSTRUCTION.
3. MESH, REBAR AND/OR A THICKER CONCRETE AND ROAD BASE SECTION MAY BE REQUIRED BASED UPON ANTICIPATED TRAFFIC LOADS.



LEHI CITY STANDARD DETAIL

**RADIUS DRIVE APPROACH**

**RD-10**

DATE:  
JANUARY 2022

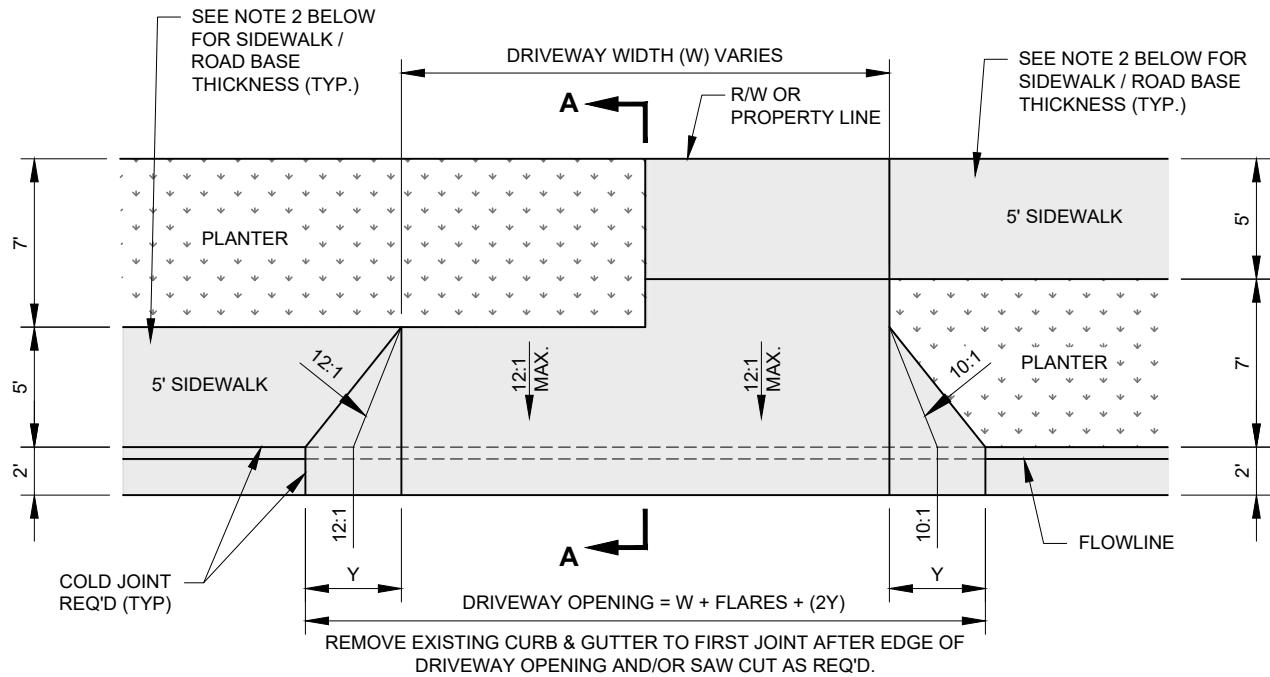

**PLAN VIEW**

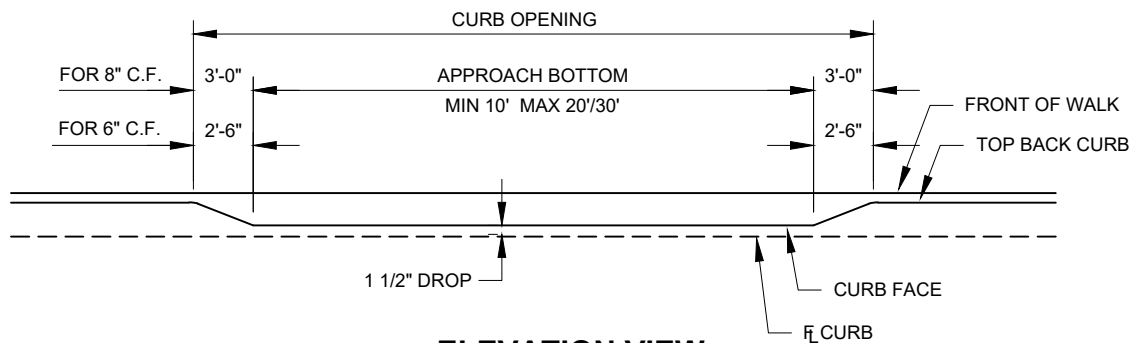

**ELEVATION VIEW**

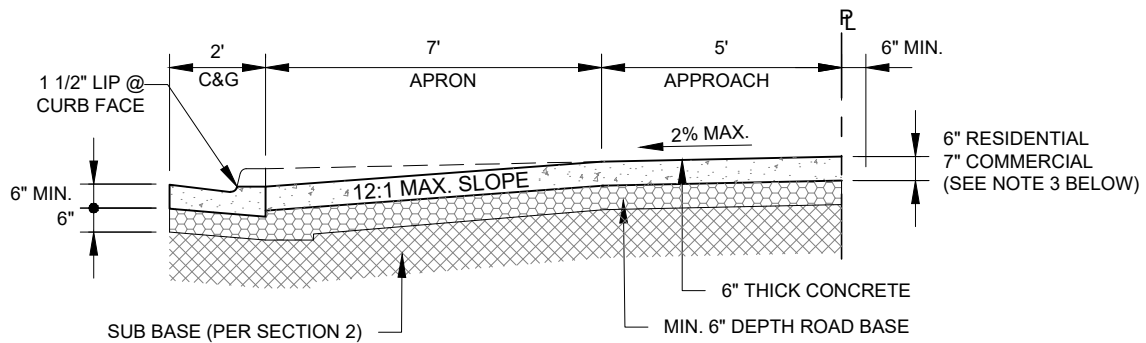

**SECTION A-A**

**GENERAL NOTES:**

1. ALL PROPOSED DRIVEWAY PLACEMENTS SHALL BE INSPECTED BY THE LEHI CITY STREET DEPARTMENT PRIOR TO POURING OF CONCRETE.
2. IN THE EVENT THAT SIDEWALKS ARE INSTALLED PRIOR TO THE INSTALLATION OF DRIVE APPROACHES, AND THEY ARE NOT CONSTRUCTED TO MEET THE STANDARDS ABOVE, ALL NON-COMPLIANT SIDEWALK SECTIONS SHALL BE REMOVED & REPLACED AS PART OF THE DRIVE APPROACH CONSTRUCTION.
3. MESH, REBAR AND/OR A THICKER CONCRETE AND ROAD BASE SECTION MAY BE REQUIRED BASED UPON ANTICIPATED TRAFFIC LOADS
4. MAX. DRIVEWAY WIDTH 20' FOR 2 CAR GARAGE, 30' FOR 3 CAR GARAGE
5. FLARED DRIVE APPROACH MAY BE ALLOWED AND/OR REQUIRED FOR PRIVATE ACCESSES WHERE ROADWAY OR PRIVATE ACCESS VOLUMES ARE LOW (SEE ACCESS MANAGEMENT STANDARDS WITHIN SECTION 2 OF THE LEHI CITY STANDARDS & PUBLIC IMPROVEMENT SPECIFICATIONS.)



LEHI CITY STANDARD DETAIL

**FLARED DRIVE APPROACH**

**RD-11**

DATE:  
JUNE 2024

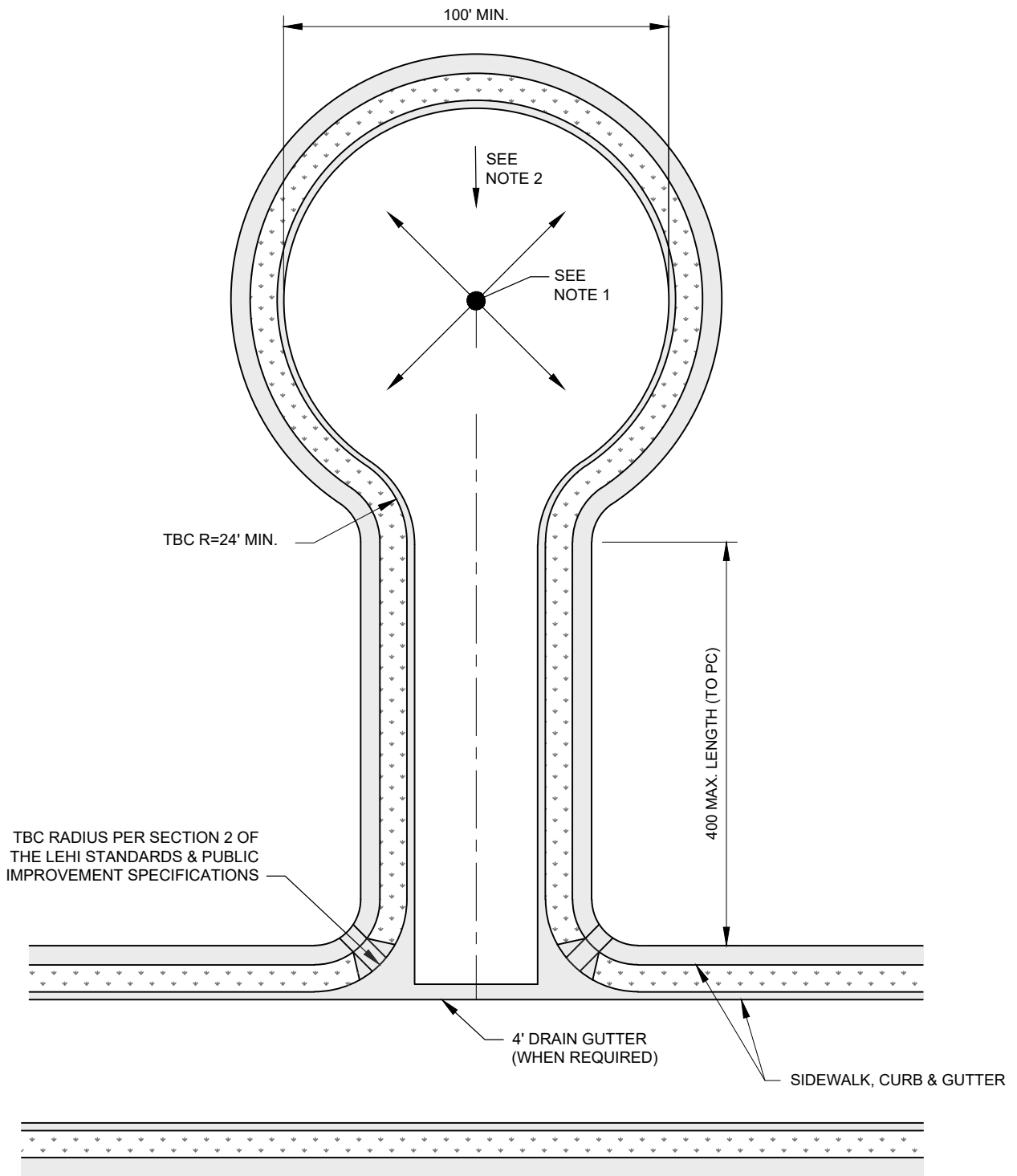

**NOTES:**

1. CUL-DE-SAC SHALL GRADE OUTWARD FROM RADIUS POINT TO CURB & GUTTER AT 2% MIN. SLOPE
2. ALTERNATE CUL-DE-SAC GRADING MAY BE PROPOSED FOR REVIEW & APPROVAL BY CITY ENGINEER. (MAXIMUM SLOPE 5% ACROSS THE CUL-DE-SAC).



LEHI CITY STANDARD DETAIL

**CUL-DE-SAC**

**RD-12**

DATE:  
MAY 2024

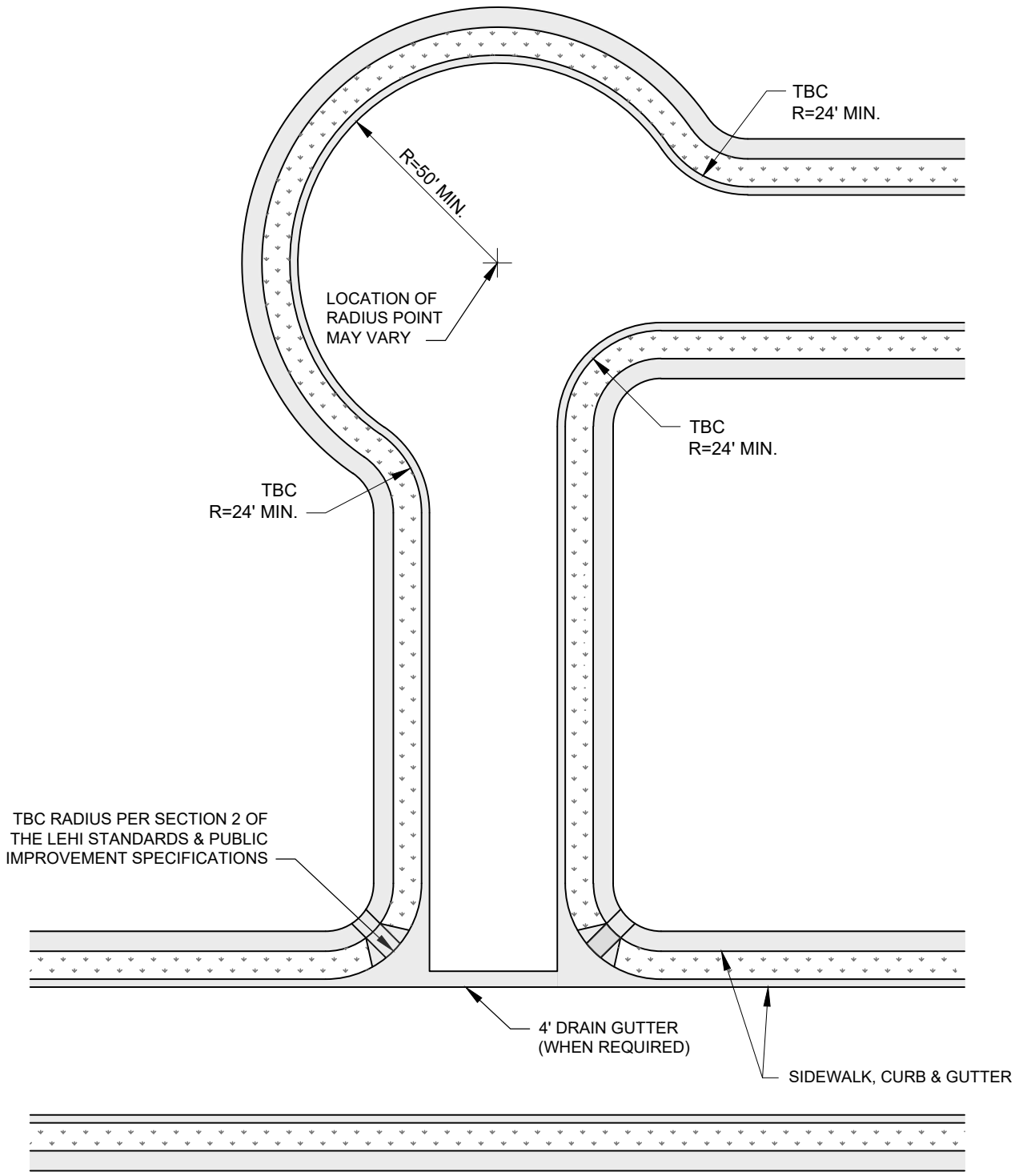

LEHI CITY STANDARD DETAIL	
<b>KNUCKLE</b>	
<b>RD-13</b>	DATE: MAY 2024

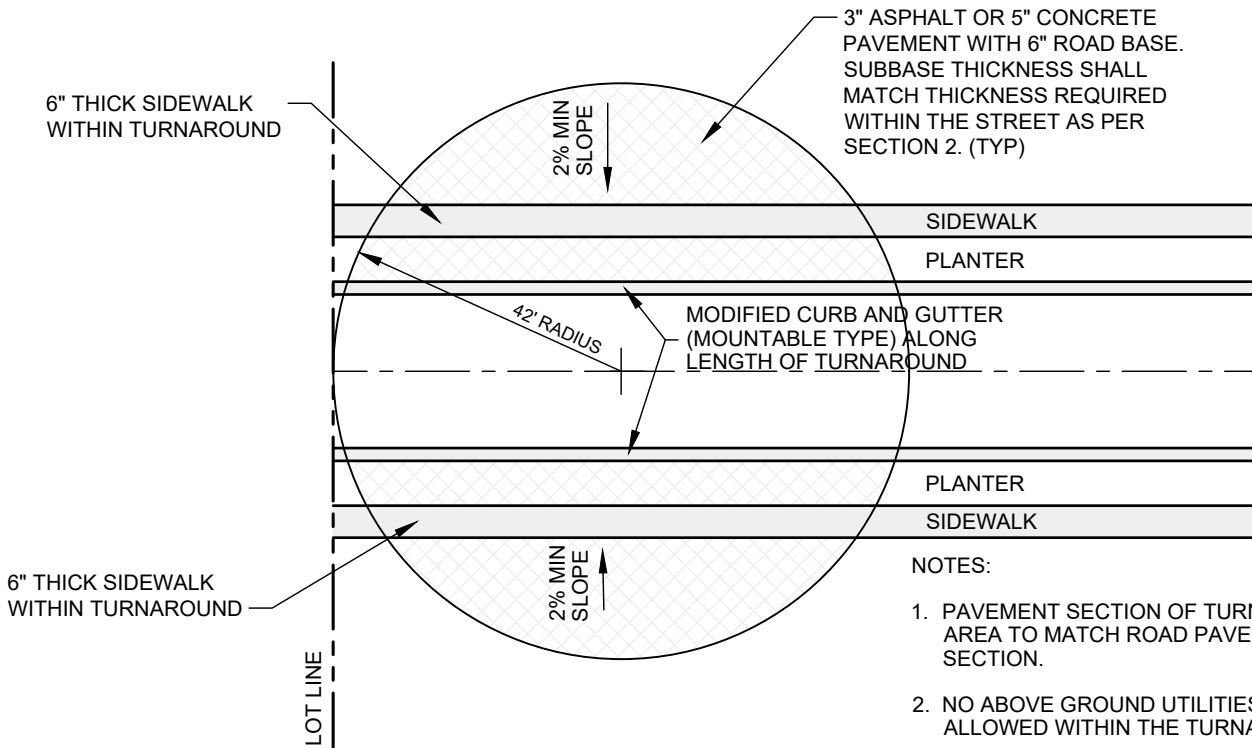

3" ASPHALT OR 5" CONCRETE PAVEMENT WITH 6" ROAD BASE. SUBBASE THICKNESS SHALL MATCH THICKNESS REQUIRED WITHIN THE STREET AS PER SECTION 2. (TYP)

6" THICK SIDEWALK WITHIN TURNAROUND

2% MIN SLOPE

SIDEWALK

PLANTER

42' RADIUS

MODIFIED CURB AND GUTTER (MOUNTABLE TYPE) ALONG LENGTH OF TURNAROUND

PLANTER

SIDEWALK

6" THICK SIDEWALK WITHIN TURNAROUND

2% MIN SLOPE

LOT LINE

**NOTES:**

1. PAVEMENT SECTION OF TURNAROUND AREA TO MATCH ROAD PAVEMENT SECTION.
2. NO ABOVE GROUND UTILITIES SHALL BE ALLOWED WITHIN THE TURNAROUND.
3. A TEMPORARY EASEMENT SHALL BE PROVIDED FOR AREA OUTSIDE OF THE CITY STREET RIGHT-OF-WAY.
4. NO PARKING SIGNS REQUIRED. 3 SIGNS LOCATED AS PER FIRE MARSHAL REVIEW.

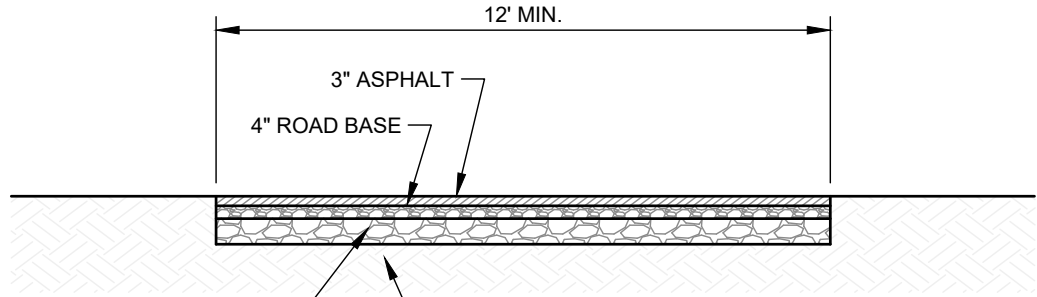

8" THICK CRUSHED ROCK, CONCRETE, OR ASPHALT

STABILIZED SUBGRADE AS MAY BE REQ'D BY THE CITY

**MAINTENANCE ACCESS WITH ASPHALT TRAIL ABOVE**

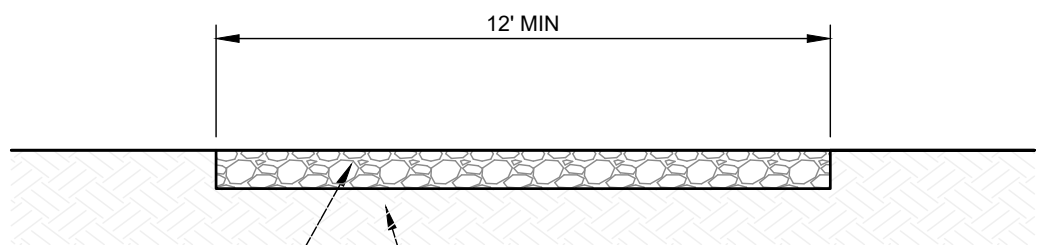

12" THICK CRUSHED ROCK, CONCRETE, OR ASPHALT

STABILIZED SUBGRADE AS MAY BE REQ'D BY THE CITY

**ALL WEATHER ACCESS**



LEHI CITY STANDARD DETAIL

**TEMPORARY TURNAROUND AND ACCESS ROADS**

**RD-14**

DATE: JANUARY 2022

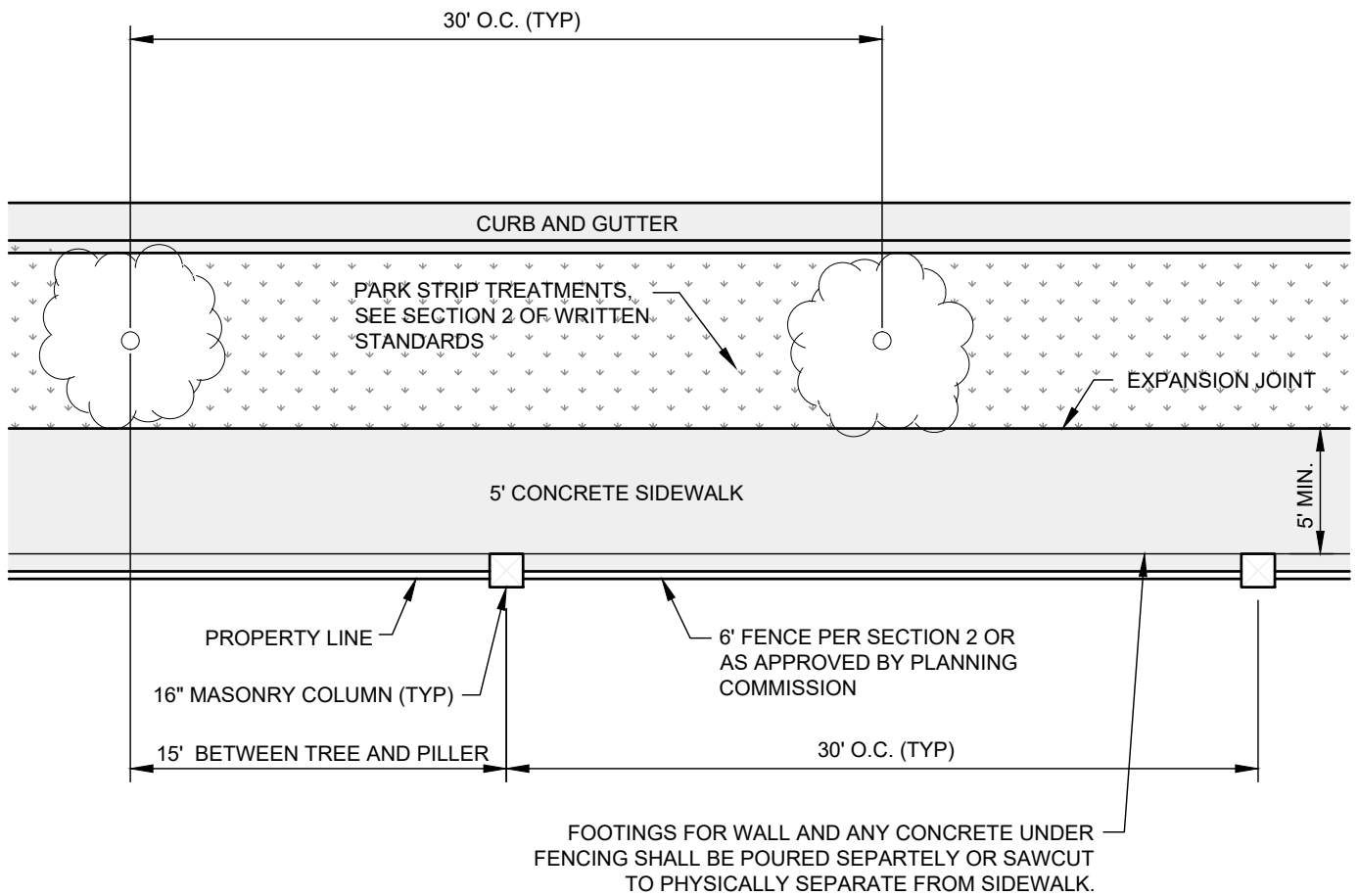

NOTES:

1. TREES IN THE PLANTER AREA SHALL BE OF A SPECIES THAT WILL NOT CAUSE ROOT DAMAGE TO CURB, GUTTER, SIDEWALK, OR ROADWAY PAVEMENT AND WILL NOT OBSTRUCT ROADWAY VISION. (TREE SPECIES TO BE APPROVED BY LEHI CITY PARKS MANAGER).
2. PROVIDE DRIP IRRIGATION SYSTEM. INSTALLATION TO BE COORDINATED BY DEVELOPER WITH LEHI CITY.
3. PROVIDE COLUMN FOOTING (30" MIN FROM GROUND SURFACE TO BOTTOM OF FOOTING)
4. TREES MAY BE CLUSTERED IN LIEU OF LINEAR SPACING.
5. IT IS STRONGLY ENCOURAGED IN THE CASE OF A SUBDIVISION WITH DOUBLE FRONTAGE LOTS THAT UP TO SIX (6) FEET OF ADDITIONAL PROPERTY IS DEDICATED AS RIGHT-OF-WAY FOR ADDITIONAL PARKWAY WIDTH. SEE SECTION 2.05 OF WRITTEN STANDARDS.



LEHI CITY STANDARD DETAIL

**FENCING & PLANTER STRIP  
IMPROVEMENTS ALONG  
LIMITED ACCESS ROADWAYS**

**RD-15**

DATE:  
JANUARY 2022

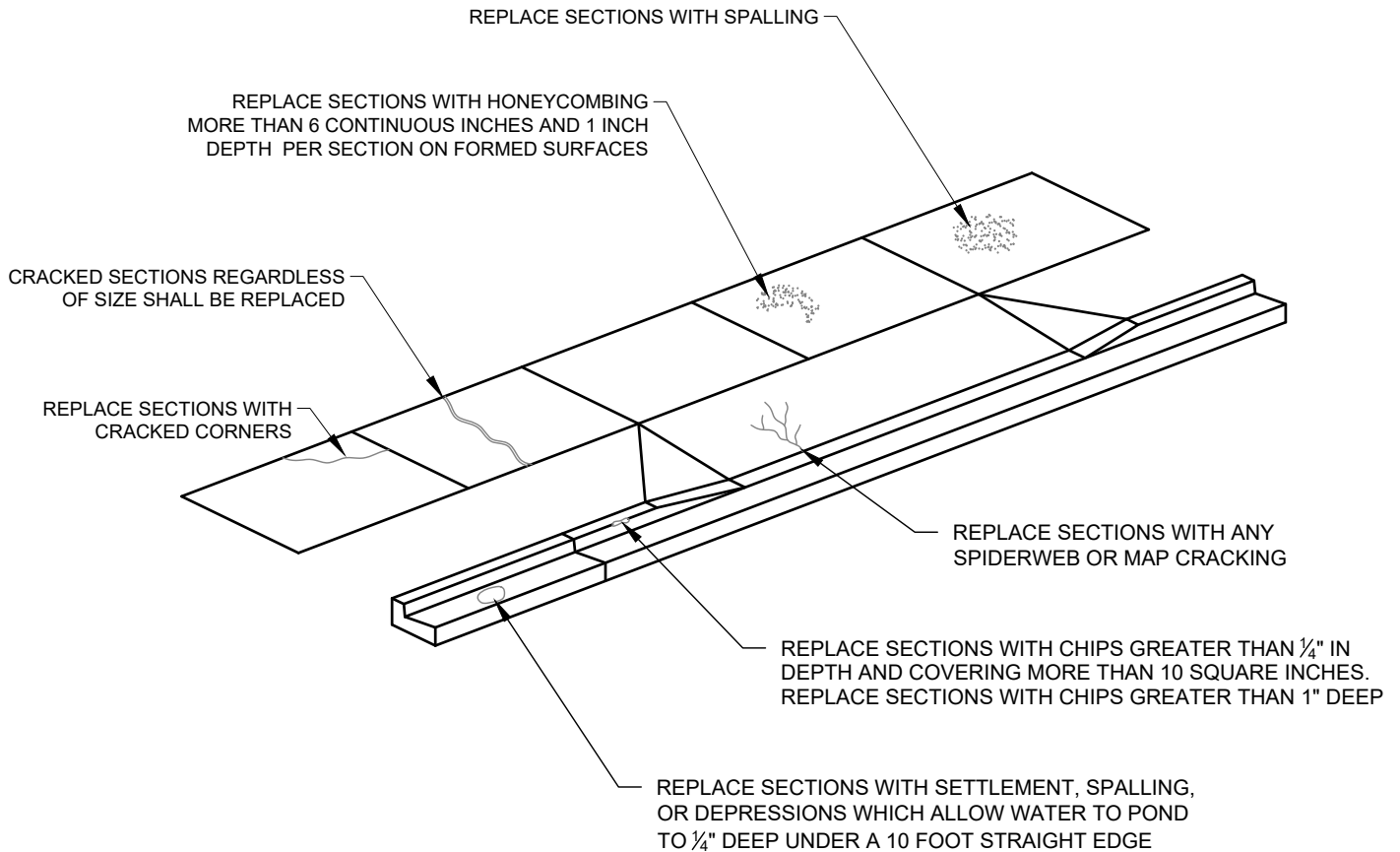

NOTES:

1. REPLACEMENT OF A COMPLETE SECTION OF SIDEWALK, CURB AND GUTTER, OR OTHER ITEM IS REQUIRED IF ONE OR MORE OF THE CONDITIONS NOTED ABOVE ARE FOUND.
2. CONDITIONS NOT SHOWN SHALL BE REPAIRED PER THE STREETS DEPARTMENT DIRECTOR RECOMMENDATIONS.
3. ALL CRACKS WITHIN SIDEWALK SECTIONS REQUIRE REPLACEMENT.
4. REPLACEMENT CONCRETE SHALL COMPLY WITH LEHI CITY DESIGN AND CONSTRUCTION STANDARDS.
5. REPLACEMENT SHALL BE DONE IN COMPLETE SECTIONS. NO PATCHING.



LEHI CITY STANDARD DETAIL

**CONCRETE REPLACEMENT  
CRITERIA**

**RD-16**

DATE:  
JANUARY 2022

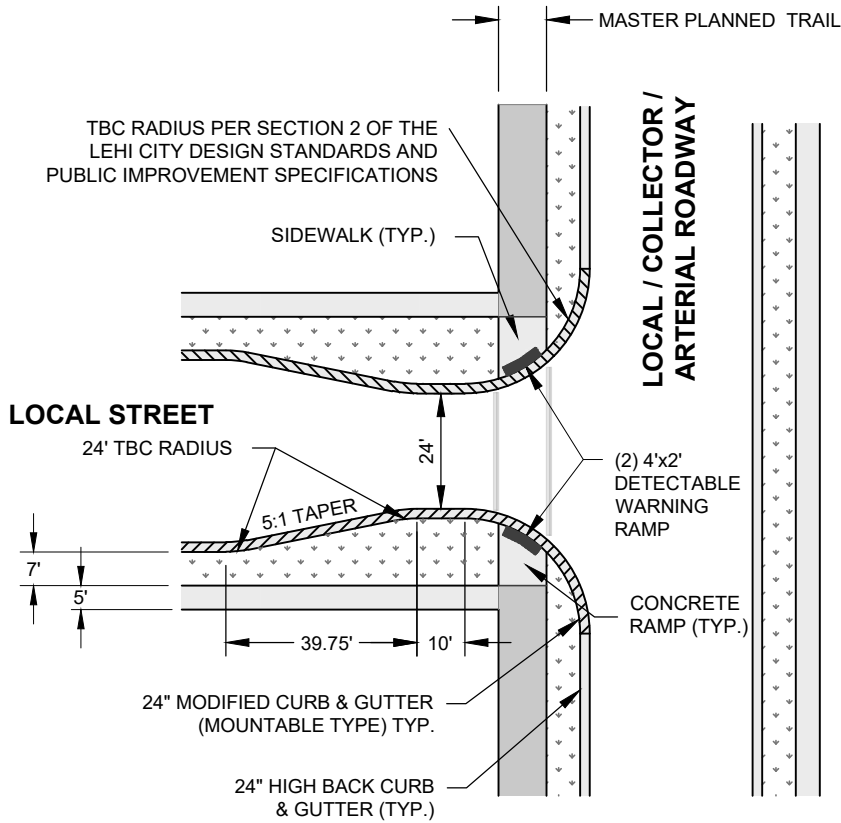

### INTERSECTION TRAIL CROSSING

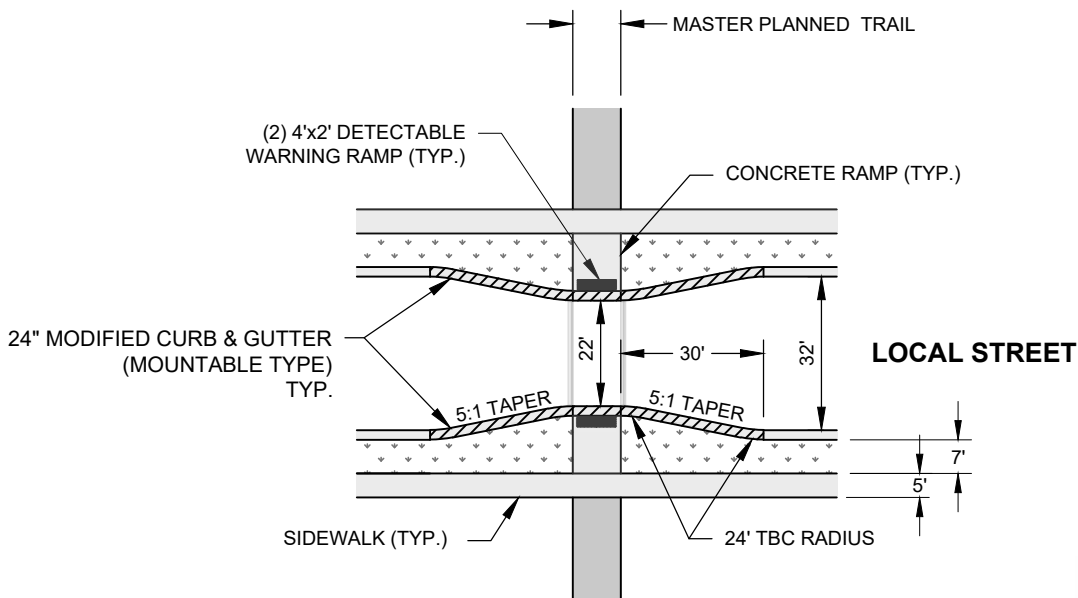

### MID-BLOCK TRAIL CROSSING



LEHI CITY STANDARD DETAIL

**MASTER PLANNED TRAIL CROSSING AT LOCAL STREET**

**RD-17**

DATE:  
MAY 2024

GENERAL NOTES:

1. DETECTABLE WARNING SURFACES SHALL BE PLACED WITHIN CONCRETE AND EXTEND 24 INCHES MINIMUM IN THE DIRECTION OF TRAVEL AND THE FULL WIDTH OF THE CURB RAMP (EXCLUSIVE OF FLARES), THE LANDING, OR THE BLENDED TRANSITION.

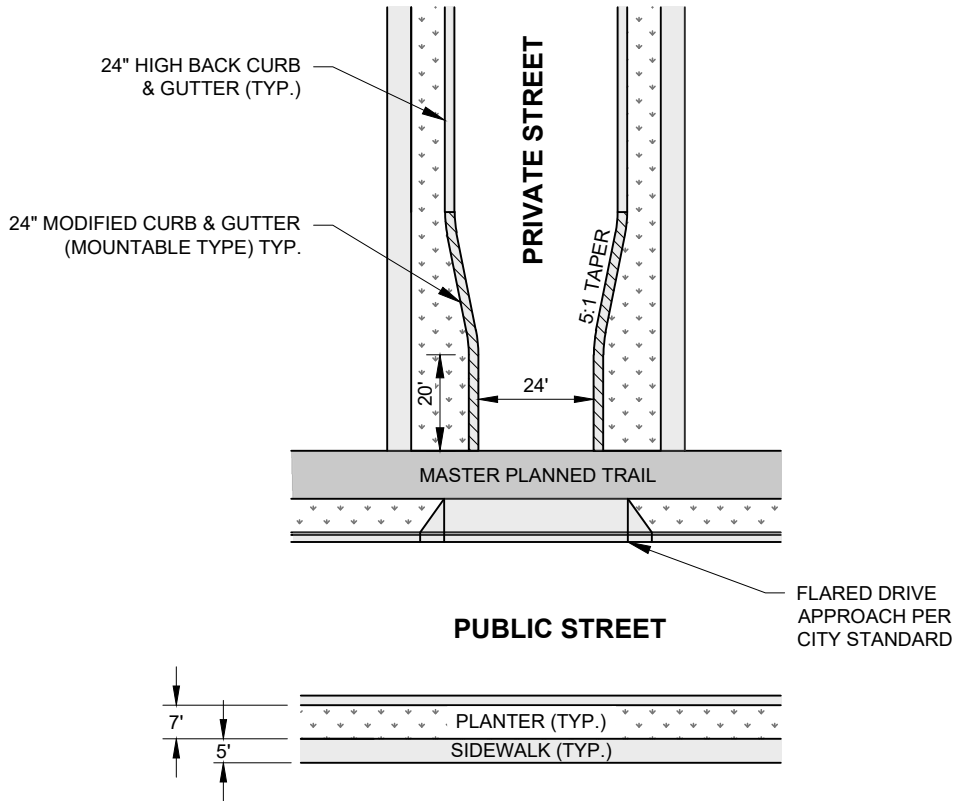

**GENERAL NOTES:**

1. THE USE OF THIS CROSS SECTION IS SUBJECT TO THE APPROVAL OF THE CITY ENGINEER.



LEHI CITY STANDARD DETAIL	
<b>CONTINUOUS TRAIL CROSSING (PRIVATE STREETS ONLY)</b>	
<b>RD-18</b>	DATE: MAY 2024

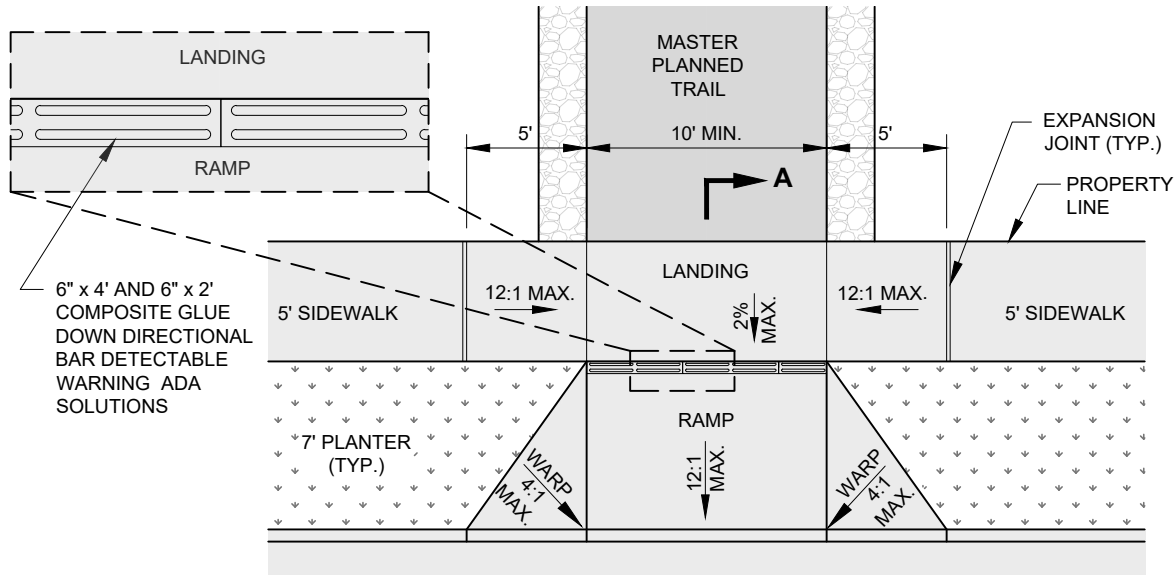

**PLAN VIEW**

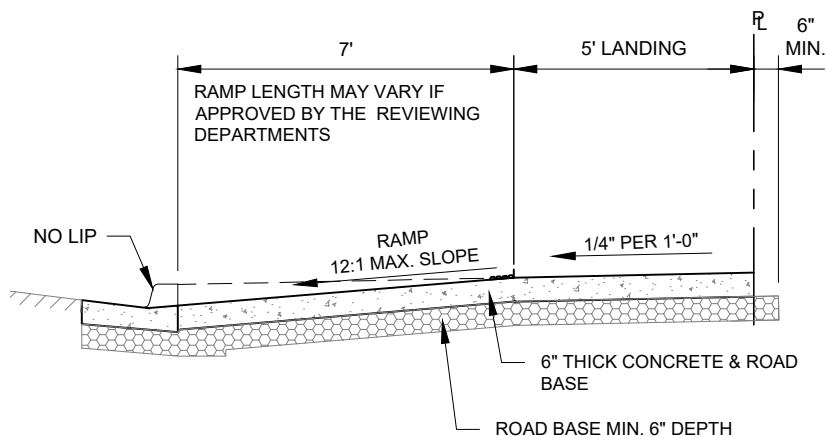

**SECTION A-A**

**GENERAL NOTES:**

1. ROAD/FIELD GRADES MAY REQUIRE ADJUSTMENT AS PER APPROVAL BY PUBLIC WORKS DEPARTMENT
2. DETECTABLE WARNING SURFACES SHALL BE PLACED IN CONCRETE AND EXTEND THE FULL WIDTH OF THE RAMP (EXCLUSIVE OF FLARES, THE LANDING, OR THE BLENDED TRANSITION.)
3. PUBLIC WORKS DEPARTMENT MUST APPROVE TYPES AND COLOR OF DETECTABLE WARNING DEVICES USED.



LEHI CITY STANDARD DETAIL

**TRAIL RAMP  
(BIKE-TO-STREET  
ACCESS ONLY)**

**RD-19**

DATE:  
MAY 2024

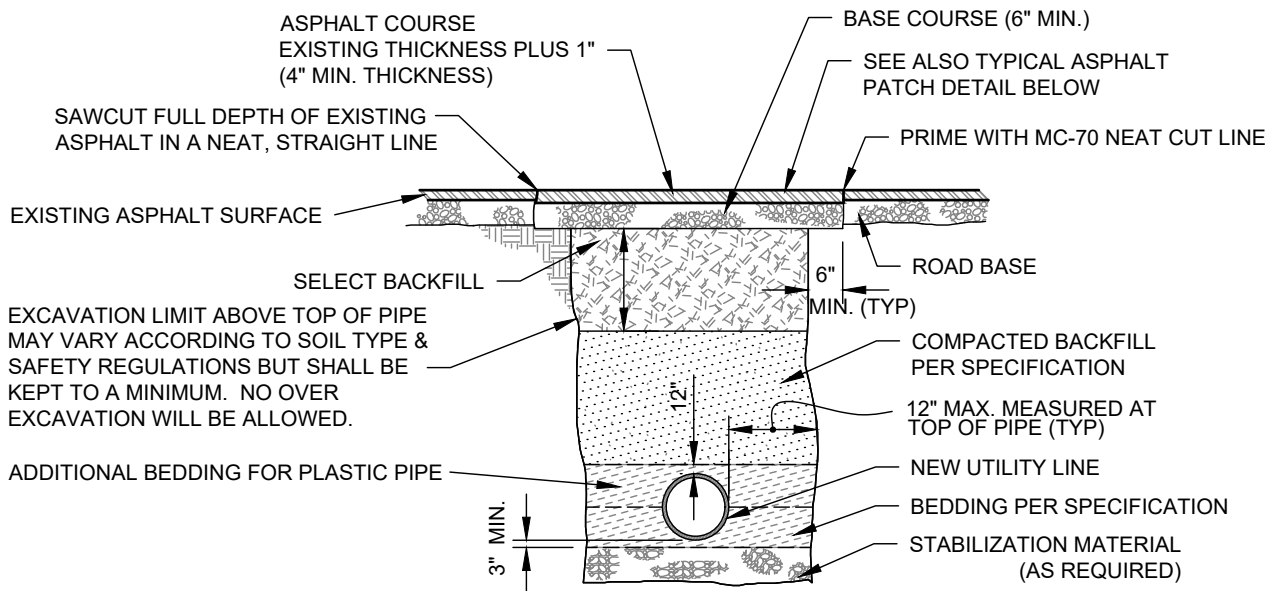

**UTILITY INSTALLATION AND ROAD REPAIR**

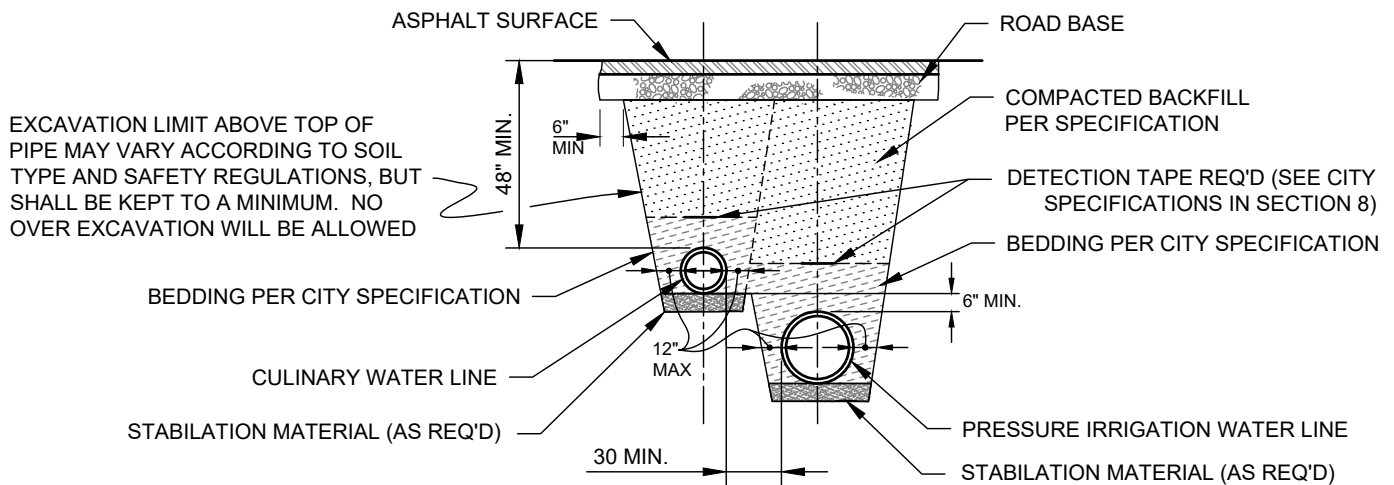

**TYPICAL DUAL PIPE INSTALLATION**

**(IRR. AND CUL)**

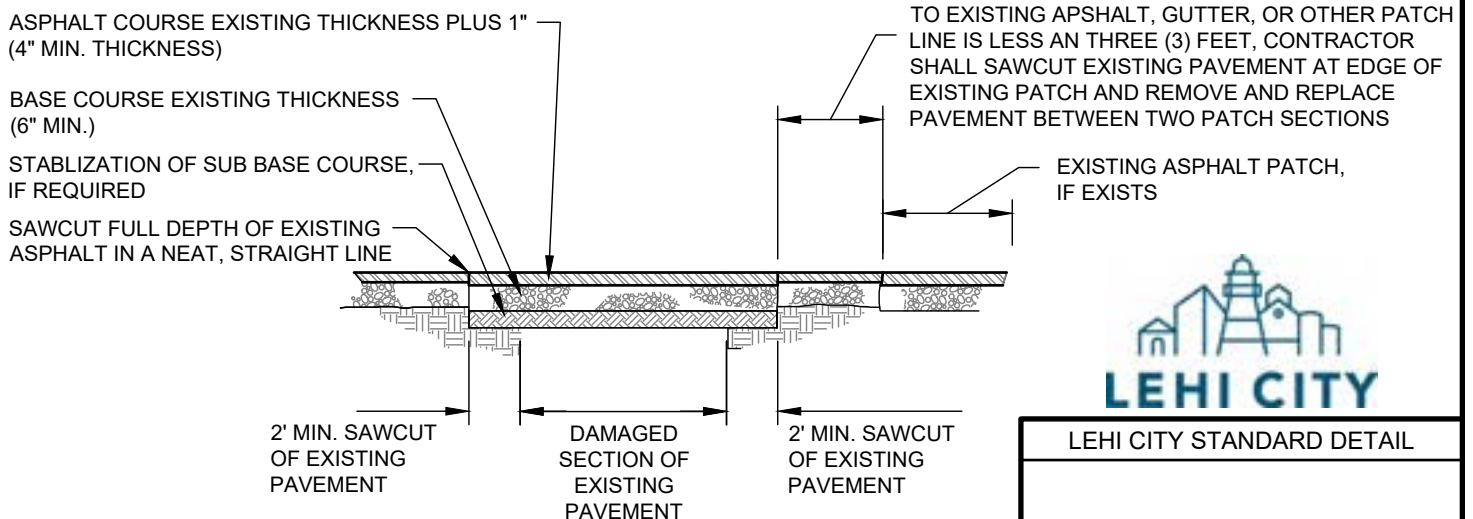

**TYPICAL ASPHALT PATCH DETAIL**



LEHI CITY STANDARD DETAIL

**UTILITY TRENCHING**

**WT-01**

DATE:  
JANUARY 2022

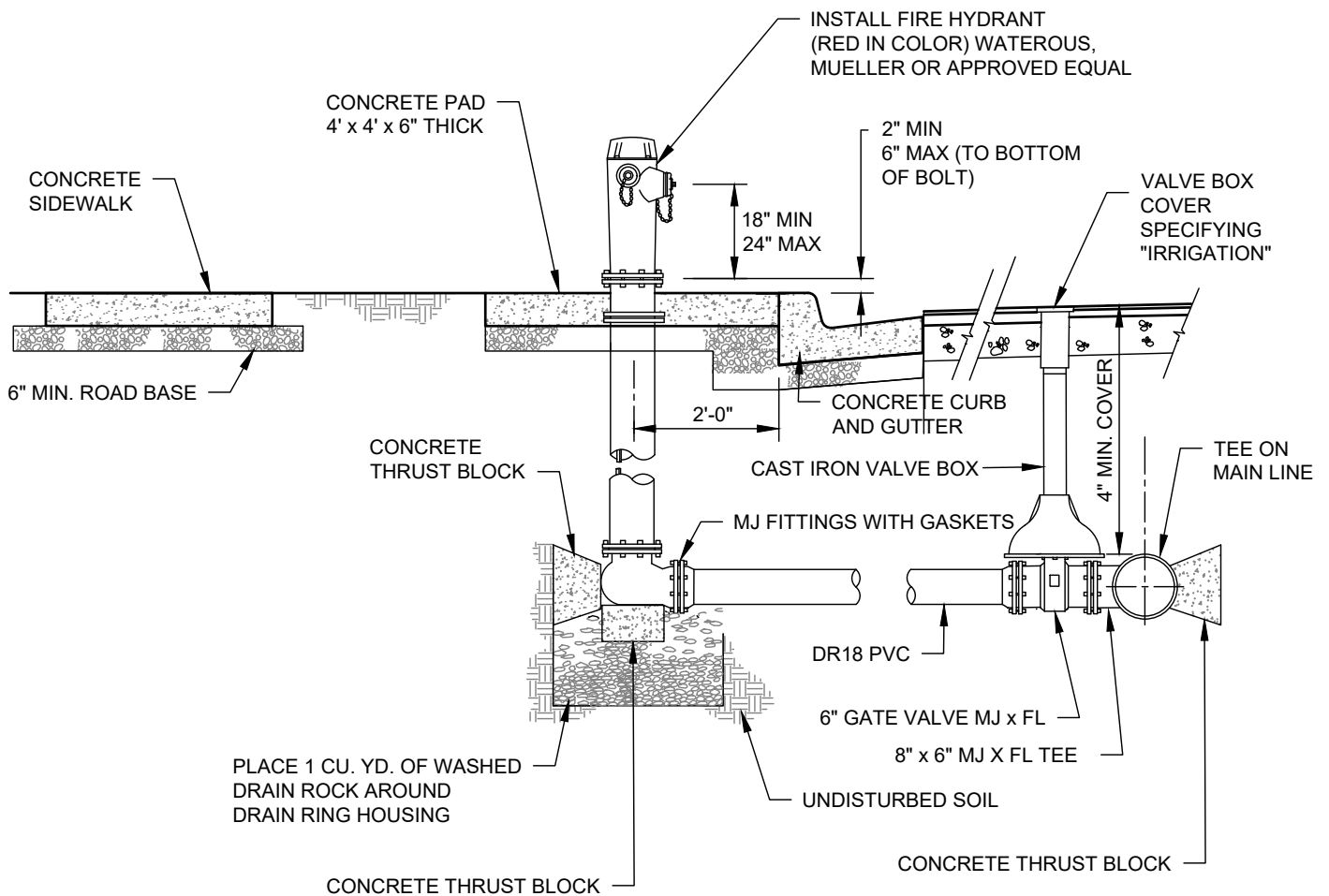

**FIRE HYDRANT WITH VALVE**

NOTES:

1. ALL BOLTS SHALL BE FREE FROM CONCRETE AND FULLY ACCESSIBLE.
2. HYDRANT SHALL BE INSTALLED 2' BEHIND THE WALK WITH CONCRETE PAD WHEN THERE IS NO PLANTER.
3. WHEN INSTALLING CONCRETE PAD AROUND FIRE HYDRANT, CONTRACTOR SHALL PLACE CRACK CONTROL JOINTS DIAGONALLY FROM THE HYDRANT TO THE CORNERS OF SAID PAD.
4. A THREE (3) FOOT HORIZONTAL CLEARANCE MUST BE MAINTAINED AROUND THE OUTSIDE OF ALL FIRE HYDRANTS.
5. STEAMER OUTLET SHALL FACE THE ROAD.



LEHI CITY STANDARD DETAIL	
<b>FIRE HYDRANT</b>	
<b>WT-02</b>	DATE: JANUARY 2022

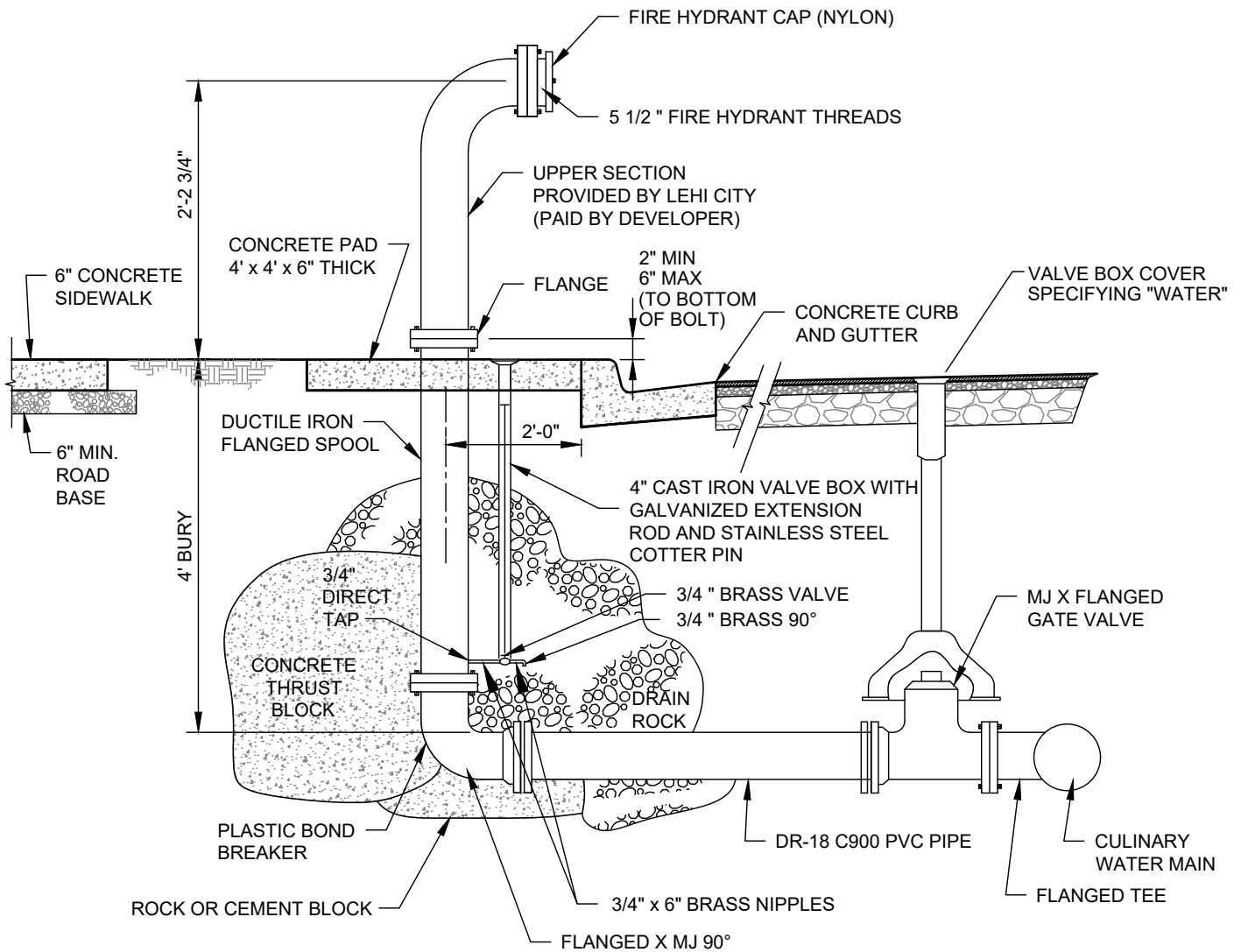

**NOTE:**

1. 4" SIZE FOR 8" OR SMALLER LINES 6" SIZE FOR 10" OR LARGER LINES OTHER SIZES AS DIRECTED BY THE WATER DEPARTMENT DIRECTOR.
2. BLOWOFF SHALL BE INSTALLED 2' BEHIND THE WALK WITH CONCRETE PAD WHEN THERE IS NO PLANTER.
3. WHEN INSTALLING CONCRETE PAD AROUND BLOW-OFF, CONTRACTOR SHALL PLACE CRACK CONTROL JOINTS DIAGONALLY FROM THE BLOW-OFF TO THE CORNERS OF SAID PAD.
4. A THREE (3) FOOT HORIZONTAL CLEARANCE MUST BE MAINTAINED AROUND THE OUTSIDE OF ALL BLOW-OFFS.
5. BLOWOFF TOP, ADAPTOR, AND CAP TO BE SUPPLIED BY LEHI CITY WATER DEPARTMENT.



LEHI CITY STANDARD DETAIL

**BLOW-OFF**

**WT-03**

DATE:  
JANUARY 2022

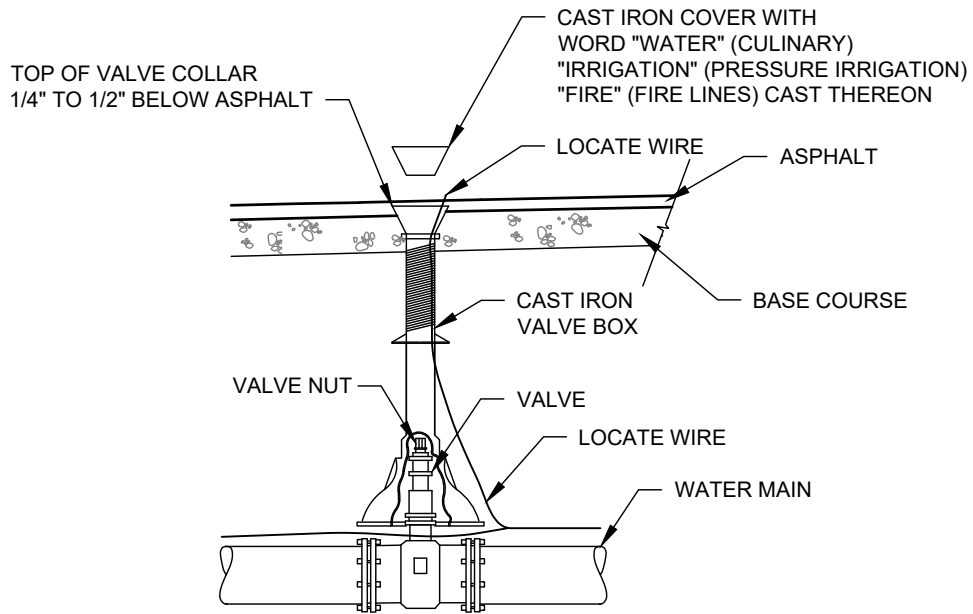

NOTES:

1. TOP OF VALVE COLLAR SHALL BE SET TO FINAL GRADE PRIOR TO PAVING. CONCRETE COLLARS MAY BE ALLOWED ONLY AFTER PRIOR APPROVAL OF LEHI CITY STREET DEPARTMENT. IF APPROVED, VALVE COLLARS SHALL BE 12" MIN. WIDE (FROM EDGE OF COLLAR), 12" THICK AND 1/4" TO 1/2" BELOW ASPHALT.
2. IN NON PAVED AND PLANTER STRIP AREAS, A 4' x 4' x 6" THICK CONCRETE PAD MUST BE PROVIDED FLUSH WITH THE TOP OF THE VALVE BOX.



LEHI CITY STANDARD DETAIL	
<b>VALVE BOX</b>	
<b>WT-04</b>	DATE: JANUARY 2022

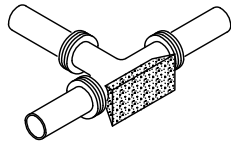

**THRUST BLOCK TYPICAL**

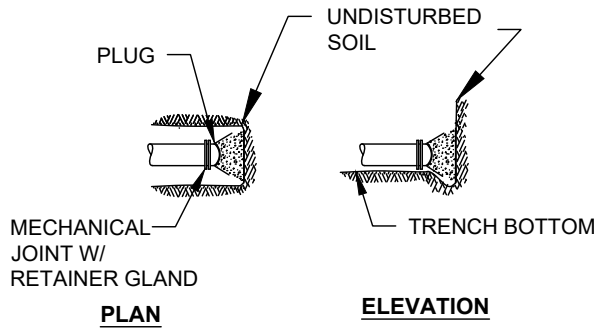

**PLUG DETAIL**

SIZE	BENDS				TEES *	GATE VALVES	DEAD ENDS	CROSS W/ 1 BRANCH PLUGGED	CROSS W/ 2 BRANCH PLUGGED
	30°	45°	22 1/2°	11 1/4°					
3	1.0	0.6	0.3	0	0.7	0.5	0.7	0.7	0.7
4	1.8	1.0	0.5	0	1.3	0.5	1.3	1.3	1.3
6	4.0	2.2	1.1	0	2.8	0.7	2.8	2.8	2.8
8	7.1	3.8	2.0	1.0	5.0	2.4	5.0	5.0	5.0
10	11.1	6.0	3.0	1.5	7.8	4.5	7.8	7.8	7.8
12	16.0	8.6	4.4	2.2	11.3	7.3	11.3	11.3	11.3
14	21.7	11.8	6.0	3.0	15.4	11.0	15.4	15.4	15.4
15	25.0	13.5	7.0	3.5	17.6	SPECIAL DESIGN	17.6	17.6	17.6
16	28.4	15.3	8.0	4.0	20.0		20.0	20.0	20.0
18	36.0	19.4	10.0	5.0	25.4		25.4	25.4	25.4
20	44.2	24.0	12.2	6.1	31.4		31.4	31.4	31.4
21	49.0	26.5	13.5	6.8	34.6		34.6	34.6	34.6
22	54.0	29.0	14.8	7.4	38.0		38.0	38.0	38.0
24	64.0	34.5	17.7	8.8	45.0		45.0	45.0	45.0
30	100.0	54.0	27.6	13.8	71.0		71.0	71.0	71.0
36	144.0	78.0	40.0	20	102.0		102.0	102.0	102.0

\* SIZE IS BRANCH SIZE

AREAS GIVEN IN TABLE ARE BASED UPON AN INTERNAL STATIC PRESSURE OF 100 P.S.I. AND A SOIL BEARING CAPACITY OF 1000 LBS. PER SQ. FT. BEARING AREAS FOR ANY PRESSURE AND SOIL BEARING CAPACITY MAY BE OBTAINED BY MULTIPLYING THE TABULATED VALUES BY A CORRECTION FACTOR "F".

F =  $\frac{\text{ACTUAL SPECIFIED TEST PRESSURE IN HUNDREDS OF LBS./SQ. IN.}}{\text{ACTUAL SOIL BEARING CAPACITY IN THOUSANDS OF LBS.}}$

**TABLE OF BEARING AREAS IN SQ. FT. FOR CONCRETE THRUST BLOCKING**

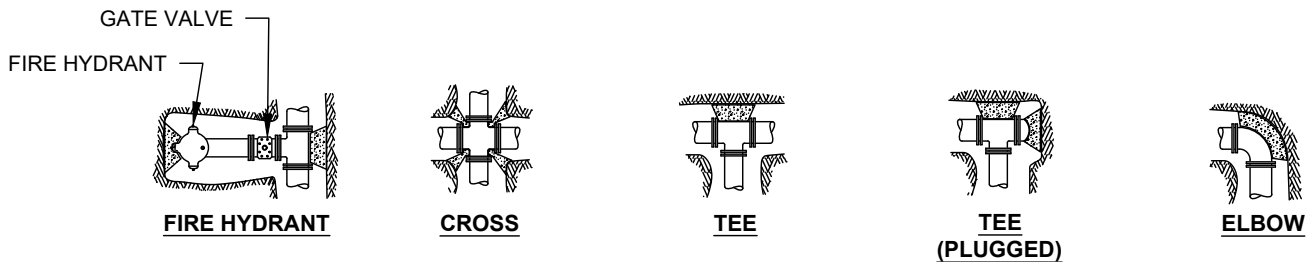

FOR 100 P.S.I. INTERNAL STATIC PRESSURE AND 1000 LBS. PER SQ. FT. SOIL BEARING CAPACITY.

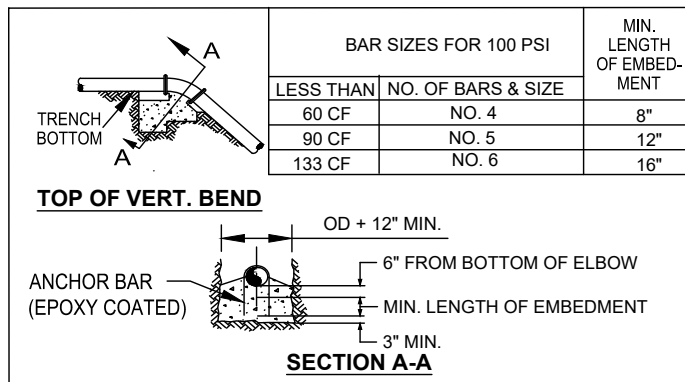

SIZE	BENDS		
	45°	22 1/2°	11 1/2°
3	3.7	1.9	1.4
4	6.5	3.3	1.7
6	14.6	7.5	3.7
8	26.0	13.2	6.6
10	40.5	20.7	10.3
12	58.5	30.0	14.8
14	79.5	40.7	20.2
15	91.0	46.6	23.2
16	104.0	53.0	26.5
18		67.3	33.4
20		83.0	41.0
21			45.5
22			50.0
24			59.5
30			
36			

REQ'D FOR VERT. BEND ANCHOR BLOCKS FOR 100 P.S.I. PRESSURE ADJUST VOLUMES BY MULTIPLYING TABULATED VALUES BY A CORRECTION FACTOR "F".

F =  $\frac{\text{ACTUAL SPECIFIED TEST PRESSURE}}{100}$

**TABLE OF VOLUMES OF CONCRETE (IN CU. FT.)**

NOTES:

- ALL FITTINGS SHALL BE COVERED WITH PLASTIC OR OTHER APPROVED MATERIAL PRIOR TO POURING THE THRUST BLOCK
- FM GRADE GREASE SHALL BE USED FOR ALL BOLTED FITTINGS.
- ALL TRUST BLOCKS AGAINST NON-NATIVE MATERIALS SHALL BE UPSIZED UNLESS A BEARING PRESSURE OF 1000 LBS. PER SQ.FT. IS PROVIDED.
- POST MIX OR SAC-CRETE IS NOT ALLOWED FOR THRUST BLOCKS.



LEHI CITY STANDARD DETAIL

**THRUST BLOCKING**

**WT-05**

DATE: JANUARY 2022

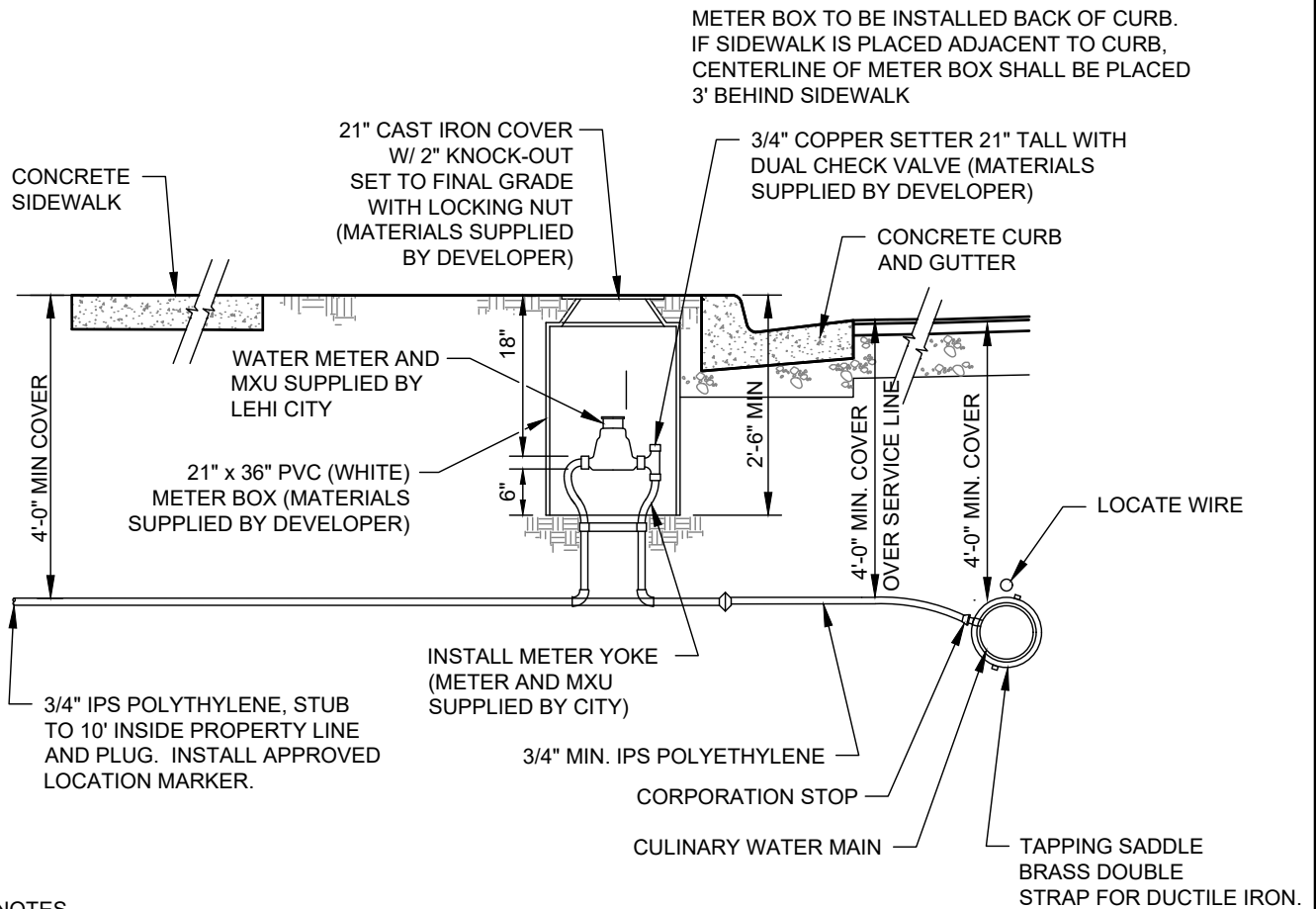

METER BOX TO BE INSTALLED BACK OF CURB. IF SIDEWALK IS PLACED ADJACENT TO CURB, CENTERLINE OF METER BOX SHALL BE PLACED 3' BEHIND SIDEWALK

**GENERAL NOTES**

1. 10'-0" EDGE TO EDGE HORIZONTAL CLEARANCE IS REQUIRED BETWEEN WATER AND SEWER LATERAL SERVICE LINES.
2. WHERE WATER AND SEWER LATERALS MUST CROSS, WATER LATERAL SHALL BE 18" ABOVE THE SEWER LATERAL AS MEASURED FROM THE BOTTOM OF THE WATER LATERAL TO THE TOP OF THE SEWER LATERAL. THIS SEPARATION SHALL BE MAINTAINED FOR A MINIMUM OF 10'-0" EITHER SIDE OF THE CROSSING POINT.
3. ALL CULINARY WATER METERS SHALL BE CONSTRUCTED BEHIND PROPOSED CURB AND GUTTER, AND SHALL BE SERVICEABLE FROM THE STREET, REGARDLESS OF WHETHER OR NOT THE TYPICAL STREET CROSS SECTION CONTAINS A PLANTER STRIP.
4. COORDINATE PLACEMENT OF WATER METER WITH LEHI WATER DEPARTMENT.
5. TEFLON TAPE REQUIRED ON ALL THREADED CONNECTIONS.
6. CULINARY WATER METERS SHALL NOT BE PLACED WITHIN DRIVABLE AREAS UNLESS OTHERWISE APPROVED BY WATER DEPARTMENT.
7. ALL PIPING, FITTINGS, ECT WILL BE PROVIDED BY DEVELOPER AND INSPECTED BY LEHI CITY WATER INSPECTOR.
8. METER AND MXU WILL BE SUPPLIED BY LEHI CITY.
9. ALL BRASS FITTINGS, VALVES, ETC. SHALL BE MANUFACTURED IN ACCORDANCE WITH AWWA STANDARD C-800, LATEST REVISION. ALL BRASS PRODUCTS ARE TO BE CERTIFIED TO THE REQUIREMENTS OF NSF / ANSI 61 ANNEX F&G AND NSF / ANSI 372.
10. HOMES WITH FIRE SPRINKLERS REQUIRE A 1" OR LARGER WATER SERVICE AS REQUIRED BY FIRE SPRINKLER DESIGN.
11. NO SPLICES OR FITTINGS ALLOWED BETWEEN THE CORPORATION STOP AND THE METER SETTER.
12. METERS THAT FALL WITHIN DRIVEWAYS MAY BE RELOCATED A MAXIMUM OF 3' Laterally, OTHERWISE THE SERVICE MUST BE TERMINATED AT THE MAIN AND REINSTALLED OUTSIDE OF THE DRIVEWAY.



LEHI CITY STANDARD DETAIL	
<b>CULINARY SERVICE CONNECTION</b>	
<b>WT-06</b>	DATE: JANUARY 2022

INSTALL 30" MANHOLE RING WITH 2" HOLE, FRAME & COVER MARKED

MANHOLE STEPS (POLYPROPYLENE COVERED STEEL) FOR ALL BOXES OVER 4' DEEP. INSTALLATION OF STEPS SHALL BE WATERPROOF

PROVIDE STRAIGHT LENGTH OF PIPE (MINIMUM 2.5 TIMES THE PIPE DIAMETER) FROM EDGE OF METER TO CLOSEST FITTING

FLG x PE SPOOL LENGTH AS REQUIRED

GATE VALVE WITH WHEEL HANDLE

FLEXIBLE COUPLING

GATE VALVE WITH WHEEL HANDLE

SPOOL WITH TAP

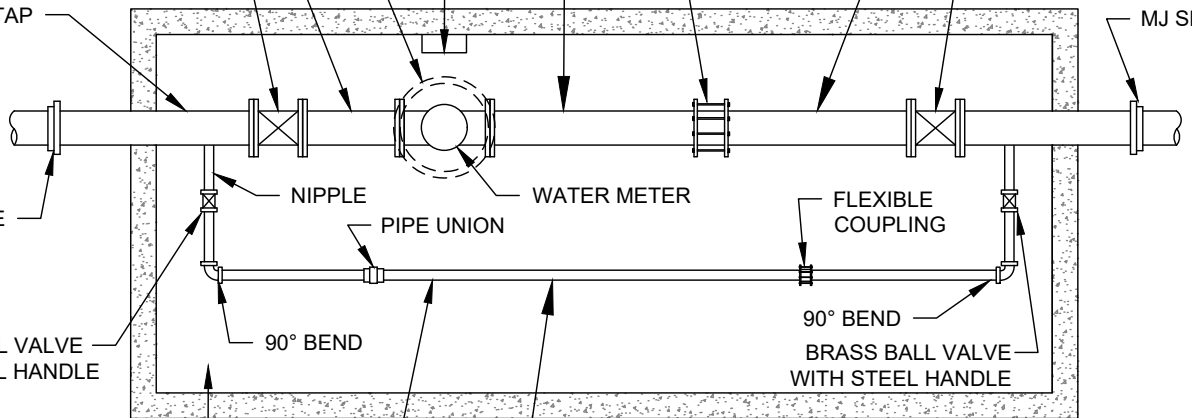

**NOTES**

1. AN ENGINEERED PRECAST BOX MAY BE ALLOWED AS APPROVED BY THE CITY.
2. STRUCTURAL DESIGN (REINFORCING AND CONCRETE THICKNESS FOR WALLS, FOOTINGS, AND ROOF) WILL DEPEND ON FINAL BOX SIZE.
3. COORDINATE METER BOX PLACEMENT AND OVERALL METER DIMENSIONS WITH LEHI WATER METERING DEPARTMENTS PRIOR TO INSTALLATION.
4. CHANGES DUE TO PIPE SIZE SHALL BE AS APPROVED BY THE CITY WATER SUPERINTENDENT.
5. METER AND MXU SUPPLIED BY LEHI CITY.
6. VAULT LID AND INTERNAL PIPING PROVIDED BY DEVELOPER



LEHI CITY STANDARD DETAIL	
<b>CONCRETE METER BOX</b>	
<b>WT-07</b>	DATE: JANUARY 2022

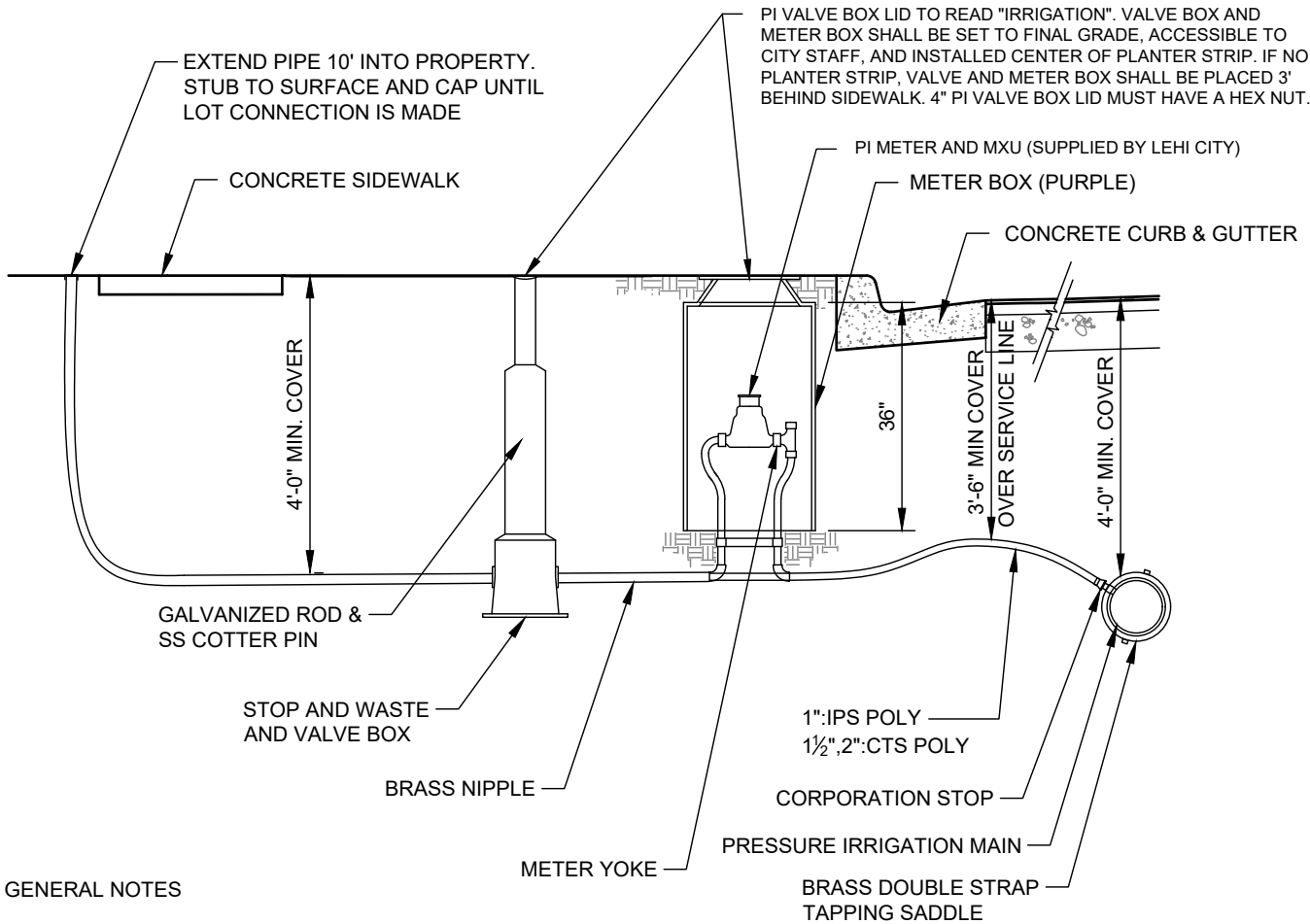

**GENERAL NOTES**

1. 10'-0" EDGE TO EDGE HORIZONTAL CLEARANCE IS REQUIRED BETWEEN WATER AND SEWER LATERAL SERVICE LINES.
2. WHERE WATER AND SEWER LATERALS MUST CROSS, WATER LATERAL SHALL BE 18" ABOVE THE SEWER LATERAL AS MEASURED FROM THE BOTTOM OF THE WATER LATERAL TO THE TOP OF THE SEWER LATERAL. THIS SEPARATION SHALL BE MAINTAINED FOR A MINIMUM OF 10'-0" EITHER SIDE OF THE CROSSING POINT.
3. ALL PRESSURE IRRIGATION METERS SHALL BE CONSTRUCTED BEHIND PROPOSED CURB AND GUTTER, AND SHALL BE SERVICEABLE FROM THE STREET, REGARDLESS OF WHETHER OR NOT THE TYPICAL STREET CROSS SECTION CONTAINS A PLANTER STRIP.
4. COORDINATE PLACEMENT OF PI METER WITH LEHI WATER DEPARTMENT.
5. TEFLON TAPE REQUIRED ON ALL THREADED CONNECTIONS.
6. PRESSURE IRRIGATION METERS SHALL NOT BE PLACED WITHIN DRIVABLE AREAS UNLESS OTHERWISE APPROVED BY WATER DEPARTMENT.
7. ALL PIPING, FITTINGS, ECT WILL BE PROVIDED BY DEVELOPER AND INSPECTED BY LEHI CITY WATER INSPECTOR.
8. METER AND MXU WILL BE SUPPLIED BY LEHI CITY.
9. ALL BRASS FITTINGS, VALVES, ETC. SHALL BE MANUFACTURED IN ACCORDANCE WITH AWWA STANDARD C-800, LATEST REVISION. ALL BRASS PRODUCTS ARE TO BE CERTIFIED TO THE REQUIREMENTS OF NSF / ANSI 61 ANNEX F&G AND NSF / ANSI 372.
10. METERS THAT FALL WITHIN DRIVEWAYS MAY BE RELOCATED A MAXIMUM OF 3' Laterally, OTHERWISE THE SERVICE MUST BE TERMINATED AT THE MAIN AND REINSTALLED OUTSIDE OF THE DRIVEWAY.

PARTS LIST			
PART NAME	METER SIZE		
	1" METER	1 1/2" METER	2" METER
SETTER	FORD VB-74-15W-11-44	FORD VBB76-15-11-66	FORD VBB77-15-11-77
NIPPLE	1X12 BRASS	1-1/2X12 BRASS	2X12 BRASS
STOP AND WASTE	FORD BC-11-444-SW 1	FORD B11-666SW-NL 1 1/2	Ford B11-777SW-NL 2
RING	D&L L-2244	D&L L-2242	
RING ADAPTER	NA	L-2336 30 CI MTR ADPT RING	
LID	DFW12AUT-5MW+T-IRRIG-LID PURPLE		
METER INSULATOR	4x28 FOAM	4x30 FOAM	
VALVE BOX	93D CAST IRON W/HEX NUT		
BASE	NA	M-9094-01	
ROD	M-9080 W/COTTER OSW EXT KEY		
METER BOX	SIGMA RMP-212436-PTR	SIGMA RMP-203036-PTR	
SERVICE LINE	1" IPS POLY	1 1/2" CTS POLY	2" CTS POLY

\*LISTED MODEL NUMBERS OR APPROVED EQUAL REQUIRED



LEHI CITY STANDARD DETAIL

**PRESSURE IRRIGATION  
SERVICE CONNECTION**

**WT-08**

DATE:  
JANUARY 2022

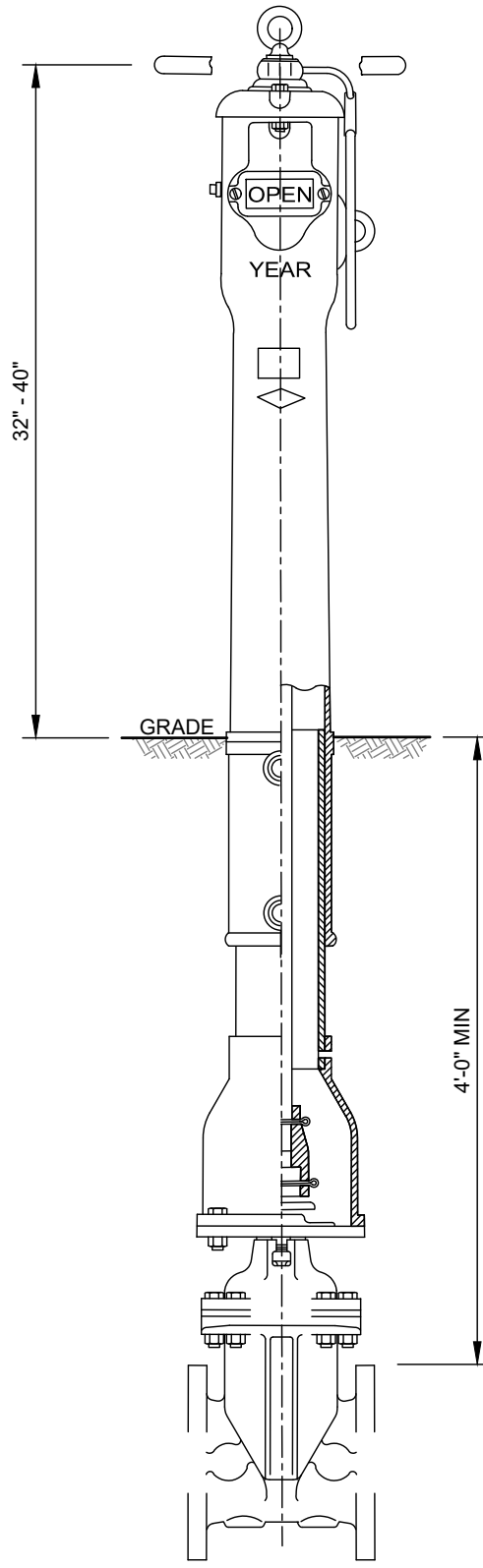

GATE VALVE SHOWN FOR REFERENCE ONLY

NOTES:

1. MUST BE PLACED IN LINE WITH FDC (FIRE DEPARTMENT CONNECTION), IN PLAIN SITE AND BE READABLE FROM THE STREET.
2. FINAL PLACEMENT SHALL BE AS APPROVED BY THE FIRE CODE OFFICIAL.
3. POST INDICATOR VALVE SHALL BE UL LISTED AND FM APPROVED.
4. POST INDICATOR VALVE SHALL BE A MINIMUM DIAMETER OF 4".
5. A THREE (3) FOOT HORIZONTAL CLEARANCE MUST BE MAINTAINED AROUND THE OUTSIDE OF ALL POST INDICATOR VALVES.
6. THERE SHALL BE NO OTHER VALVES BETWEEN THE POST INDICATOR AND THE FIRE SPRINKLER RISER.
7. THERE SHALL BE NO WATER CONNECTIONS OTHER THAN THE POST INDICATOR VALVE BETWEEN THE MAINLINE VALVE AND THE RISER FLANGE.
8. A POST INDICATOR VALVE IS REQUIRED ON ALL FIRE LINES EXCEPT WHEN THERE IS AN OUTSIDE DOOR TO THE FIRE RISER ROOM AND AS REQUIRED BY THE FIRE MARSHALL.



LEHI CITY STANDARD DETAIL	
<b>POST INDICATOR VALVE</b>	
<b>WT-09</b>	DATE: JANUARY 2022

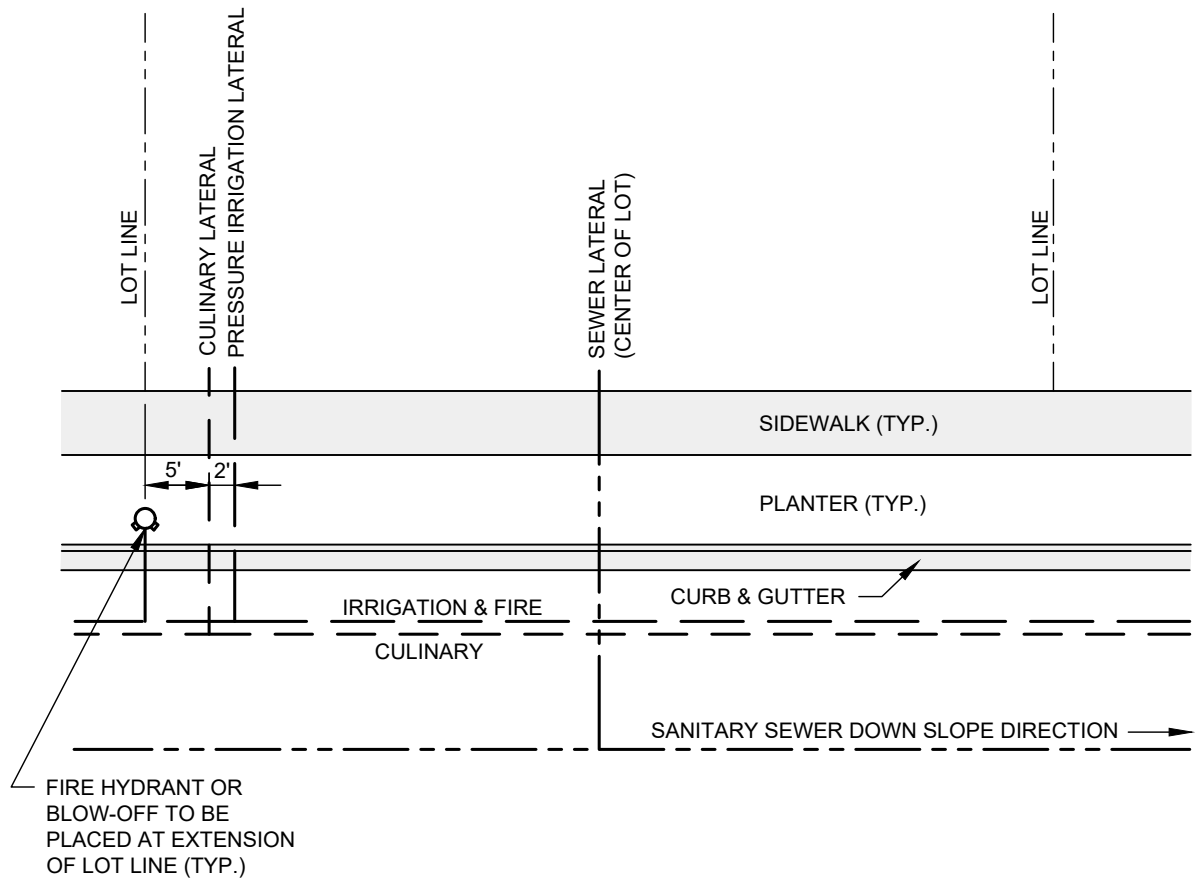

#### NOTES

1. EACH SUBDIVISION LOT SHALL RECEIVE ONLY ONE (1) OF EACH SERVICE TYPE (WATER, P.I., SEWER OR SUB-DRAIN) UNLESS SPECIFICALLY AUTHORIZED BY THE CITY COUNCIL, CITY ENGINEER AND THE WATER SUPERINTENDANT.
2. ALL REMOVALS OR CHANGES TO EXISTING LATERAL LOCATIONS SHALL BE PERFORMED AT THE DEVELOPERS EXPENSE AND BE INSPECTED BY LEHI CITY STAFF.
3. CULINARY & PRESSURIZED IRRIGATION LATERALS SHOULD BE PLACED AT A 5 FOOT OFFSET FROM THE PROPERTY LINE.
4. LOCATION CHANGES DUE TO LOT SIZE & PHYSICAL CONDITIONS SHALL BE APPROVED BY THE WATER SUPERINTENDANT.



LEHI CITY STANDARD DETAIL

**TYPICAL SERVICE,  
HYDRANT & BLOW-OFF  
LOCATIONS**

**WT-10**

DATE:  
JANUARY 2022

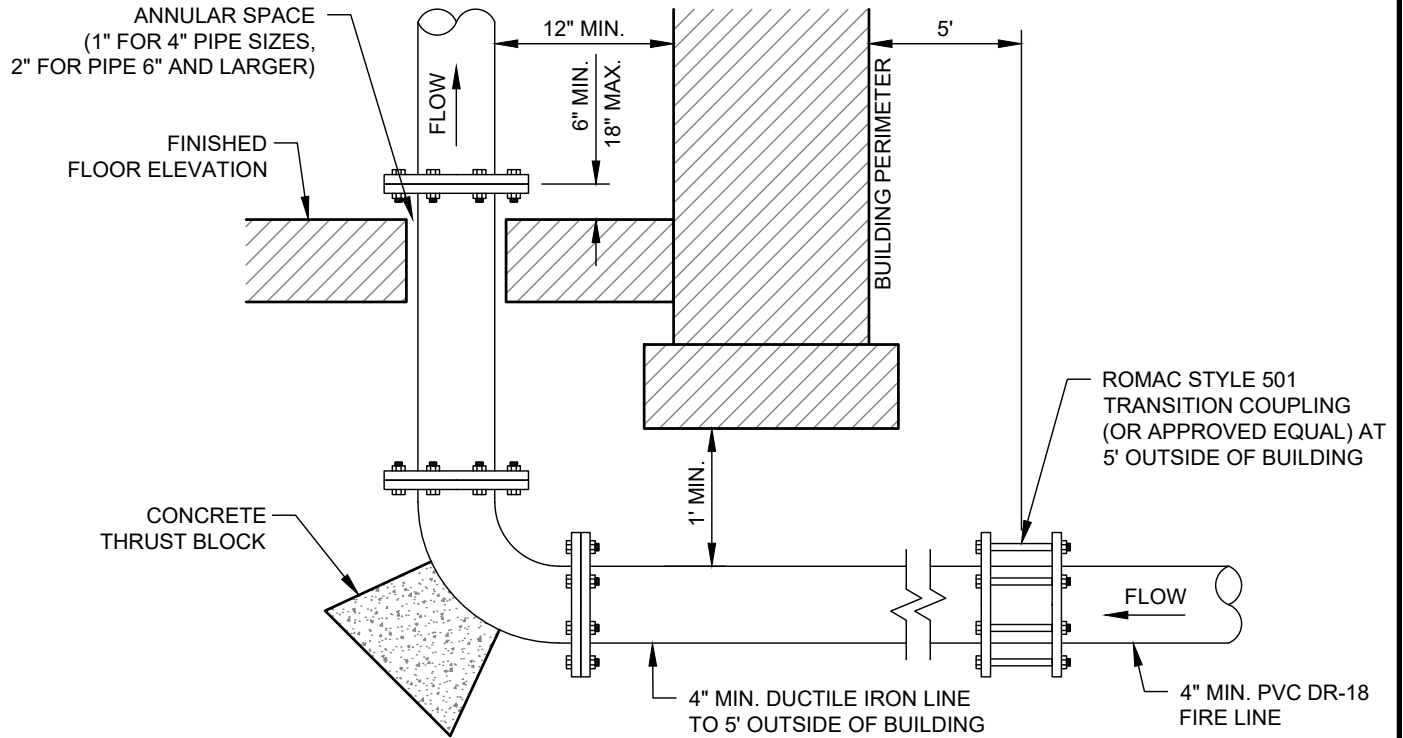

**FIRE RISER DETAIL (CLASS 50 DUCTILE IRON)**

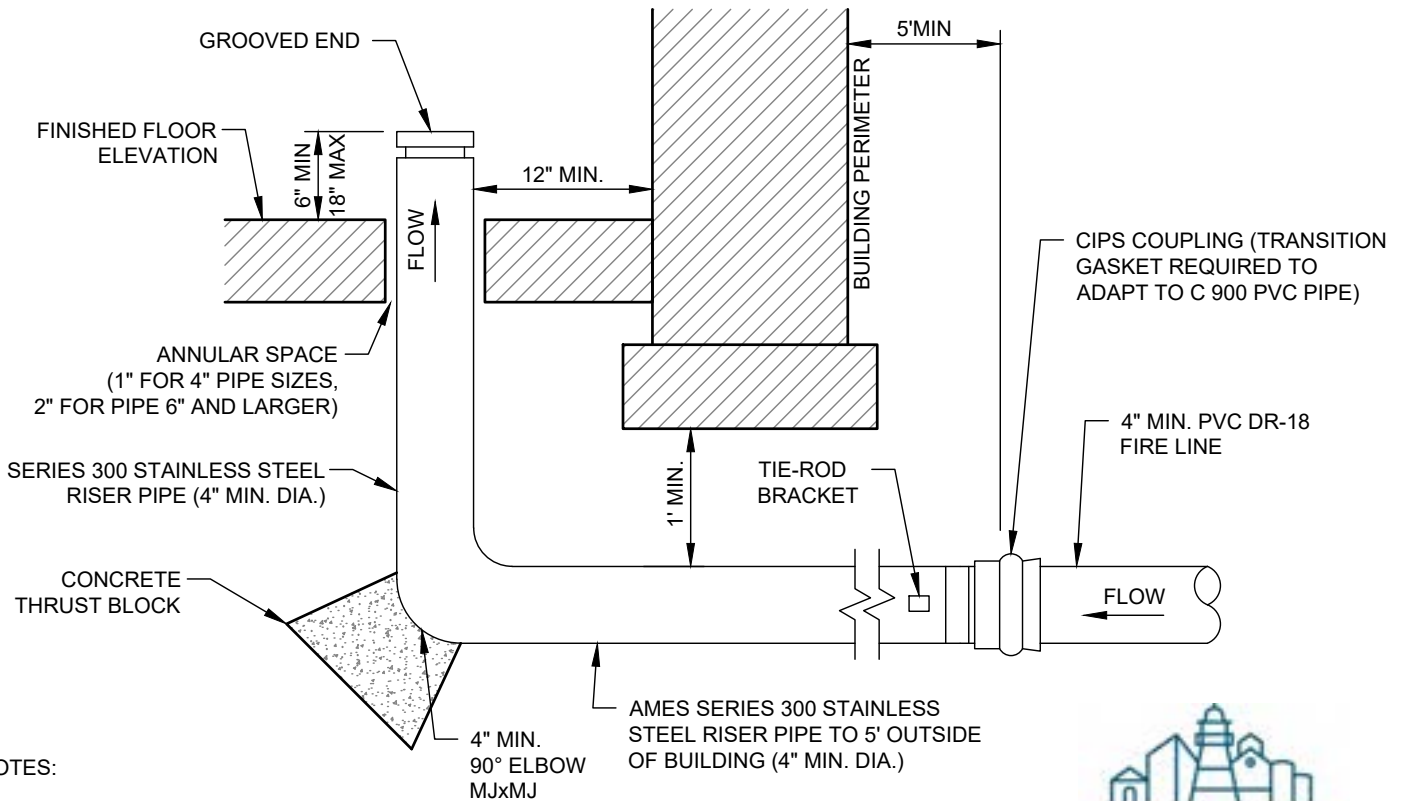

**NOTES:**

1. CLEAR & UNOBSTRUCTED WIDTH OF 36" IN FRONT OF ALL EQUIPMENT REQUIRED.
2. DOOR SWING SHALL BE IN AN OUTWARD DIRECTION.
3. THE FIRE LINE SHALL NOT EXTEND MORE THAN 10 FEET UNDER THE FLOOR SLAB.

**UNDERGROUND FIRE RISER DETAIL (STAINLESS STEEL)**



LEHI CITY STANDARD DETAIL

**TYPICAL FIRE RISER DETAILS**

**WT-11**

DATE: JANUARY 2022

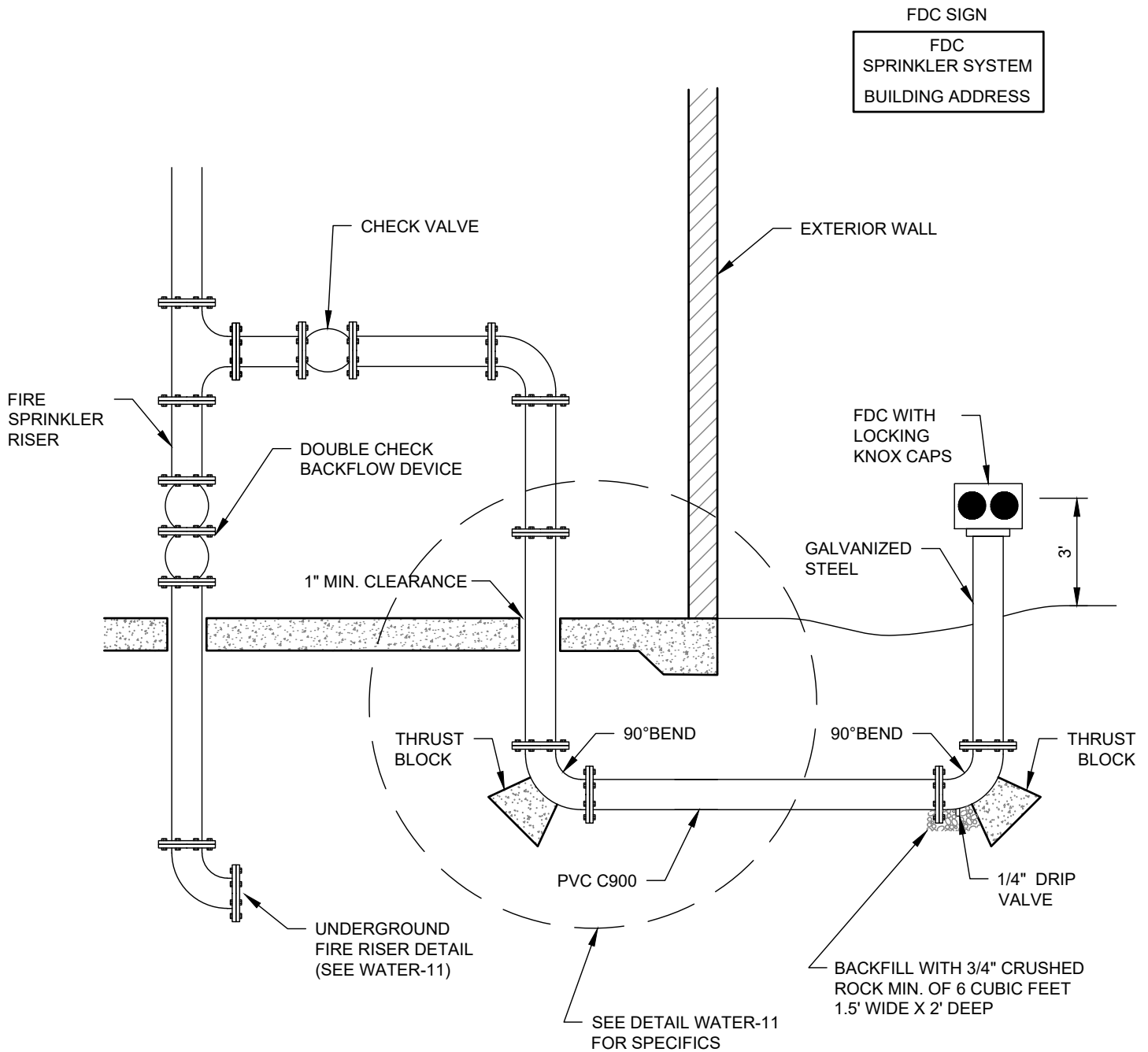

**REMOTE FIRE DEPARTMENT CONNECTION**

NOTES:

1. BY APPROVAL OF THE FIRE CODE OFFICIAL.
2. PROVIDE BUILDING ID ON FDC THE SIGN SHALL BE 12" x 12" x 2" WHITE LETTERS ON A RED REFLECTIVE BACKGROUND.
3. NO OBSTRUCTIONS, PLANTS, ETC. WITHIN 3' OF THE FDC.
4. 4' x 4' x 6" CONCRETE PAD AT BASE OF FDC.
5. FDC SHALL BE WITHIN 100' OF A FIRE HYDRANT.

FDC SIGN  
 FDC  
 SPRINKLER SYSTEM  
 BUILDING ADDRESS



LEHI CITY STANDARD DETAIL	
<b>REMOTE FIRE DEPARTMENT CONNECTION</b>	
<b>WT-12</b>	DATE: JANUARY 2022

18" CAST IRON COVER W/ 2" KNOCK-OUT SET TO FINAL GRADE WITH LOCKING NUT (MATERIALS SUPPLIED BY LEHI CITY)

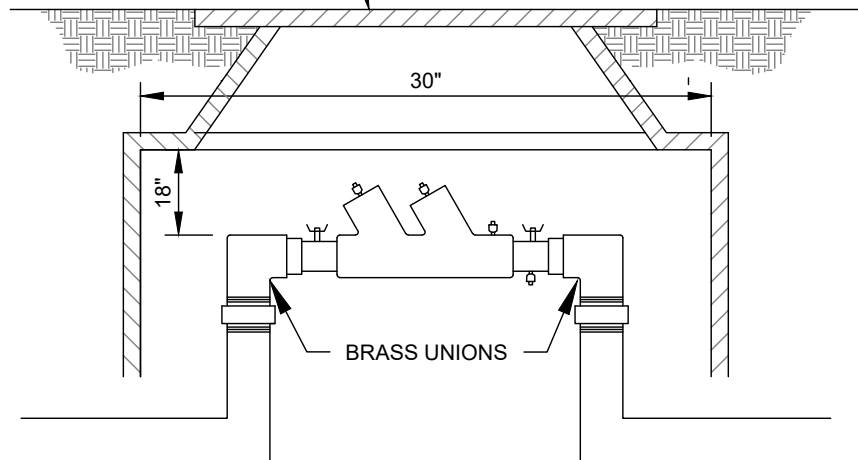

### **DOUBLE CHECK BACKFLOW PREVENTER**

NOTES:

1. MUST BE INSTALLED IN A 30" METER BOX.
2. PIPEWORK MUST BE BRASS OR RIGID COPPER (ONLY). ALL PARTS SHALL CONFORM TO THE AWWA C-800 NO LEAD RULE.
3. AFTER INSTALLATION, BACKFLOW PREVENTER MUST BE TESTED WITHIN 10 DAYS AND RESULTS GIVEN TO LEHI CITY WATER DEPARTMENT.
4. DOUBLE CHECK BACKFLOW PREVENTOR INSTALLED IN A VAULT MUST BE TESTABLE AND MAINTAINABLE FROM THE TOP POSITION.

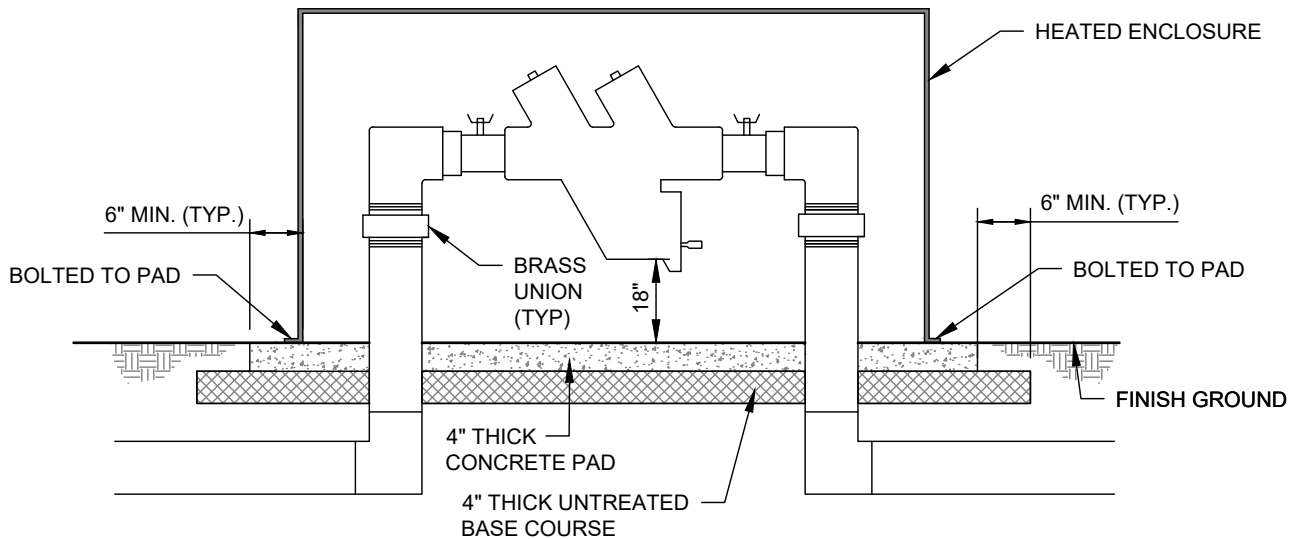

### **REDUCED PRESSURE BACKFLOW PREVENTER**

NOTES:

1. PIPEWORK MUST BE BRASS OR RIGID COPPER (ONLY). ALL PARTS SHALL CONFORM TO THE AWWA C-800 NO LEAD RULE.
2. HEAT SOURCE DESIGNED TO PROTECT BACKFLOW PREVENT TO -30 F MUST BE INSTALLED WITHIN HEATED ENCLOSURE.
3. HEATED ENCLOSURE MUST BE INSTALLED AND ANCHORED TO PAD.
4. AFTER INSTALLATION, BACKFLOW PREVENTER MUST BE TESTED WITHIN 10 DAYS AND RESULTS GIVEN TO LEHI CITY WATER DEPARTMENT.



LEHI CITY STANDARD DETAIL

### **BACKFLOW PREVENTION**

**WT-13**

DATE:  
JANUARY 2022

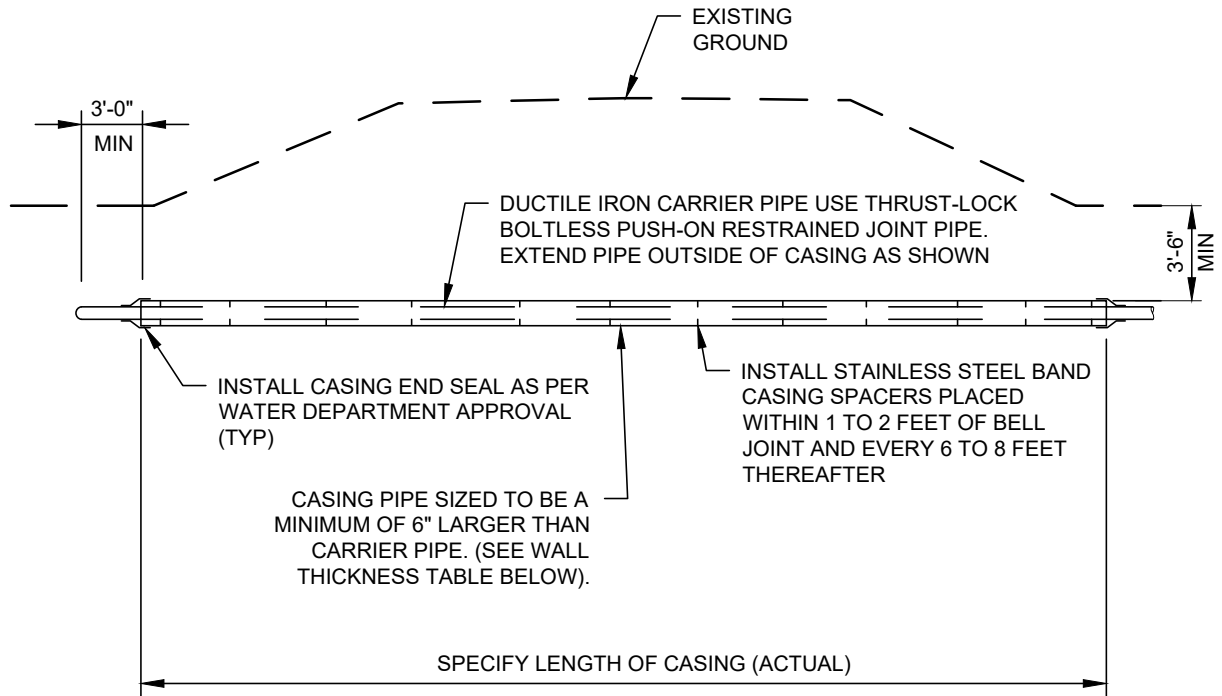

STEEL CASING PIPE WALL THICKNESS TABLE	
MINIMUM THICKNESS	DIAMETER OF CASING PIPE
1/4"	12" OR LESS
5/16"	12" - 18"
3/8"	18" - 22"
7/16"	22" - 28"
1/2"	28" - 34"
9/16"	34" - 42"
5/8"	42" - 48"
AS APPROVED	OVER 48"

\* THIS CHART IS ONLY FOR SMOOTH STEEL CASING PIPES WITH A MINIMUM YIELD STRENGTH OF 35,000 PSI.

\* CASING PIPES LARGER THAN 48" OR WITH ANY PORTION DEEPER THAN 20 FEET SHALL REQUIRE STAMPED STRUCTURAL CALCULATIONS PRIOR TO APPROVAL



LEHI CITY STANDARD DETAIL

**UTILITY CASING**

**WT-14**

DATE:  
JANUARY 2022



**KNOX BRAND LOCKING FDC CAP**  
 (FOR EXTERIOR FIRE DEPARTMENT CONNECTIONS)

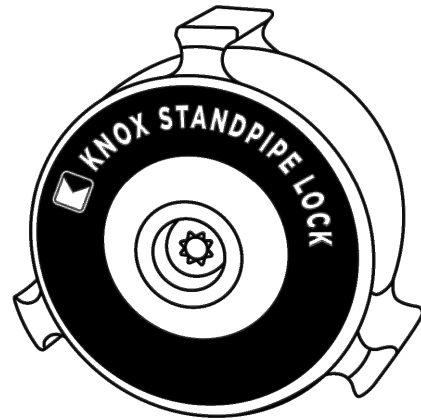

**KNOX BRAND LOCKING STANDPIPE CAP**  
 (FOR STANDPIPE HOSE CONNECTIONS)

PURCHASE THROUGH LOCAL KNOX  
 VENDOR OR AT KNOXBOX.COM

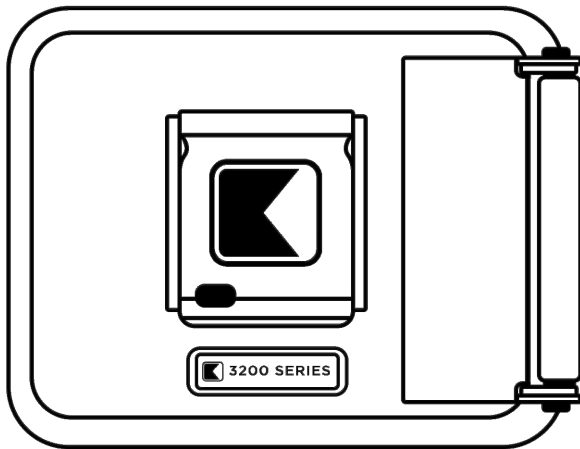

**KNOX BOX, FLUSH OR SURFACE MOUNTED**  
 (3200 SERIES)  
 (MULTIPLE BOXES MAY BE REQUIRED)

TO BE MOUNTED BETWEEN 5'-6" ABOVE  
 FINISHED FLOOR GRADE

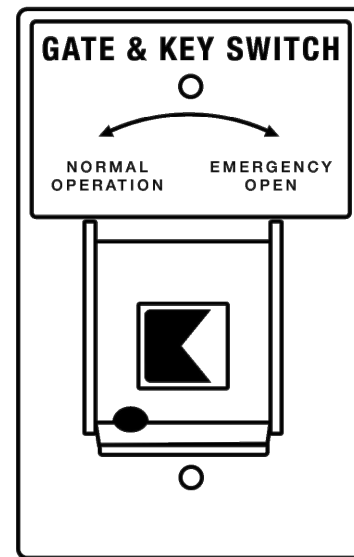

**KNOX GATE SWITCH**  
 (FOR ELECTRONIC GATE ACCESS)



LEHI CITY STANDARD DETAIL

**FIRE DEPARTMENT**

**WT-15**

DATE:  
 MAY 2024

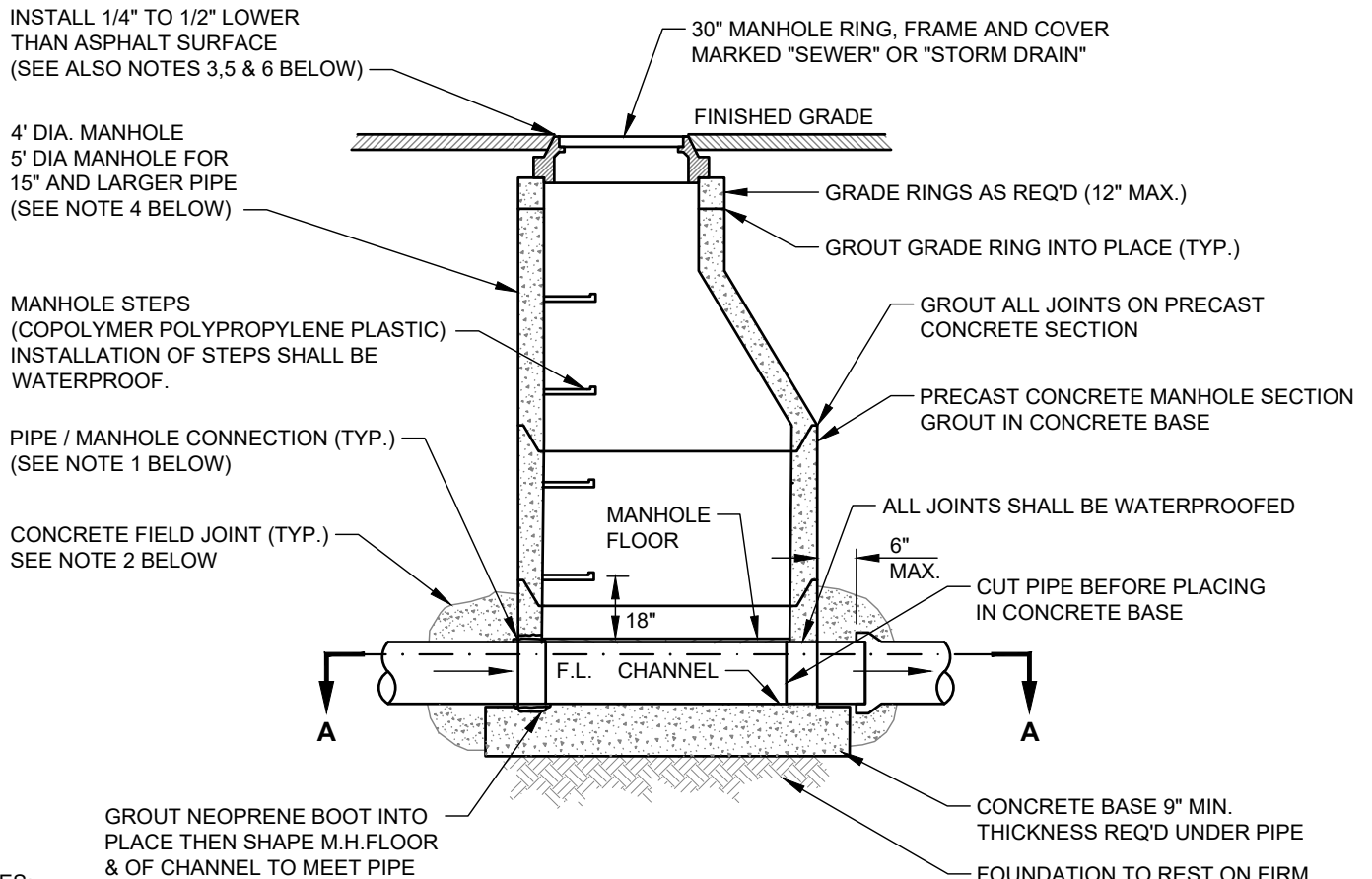
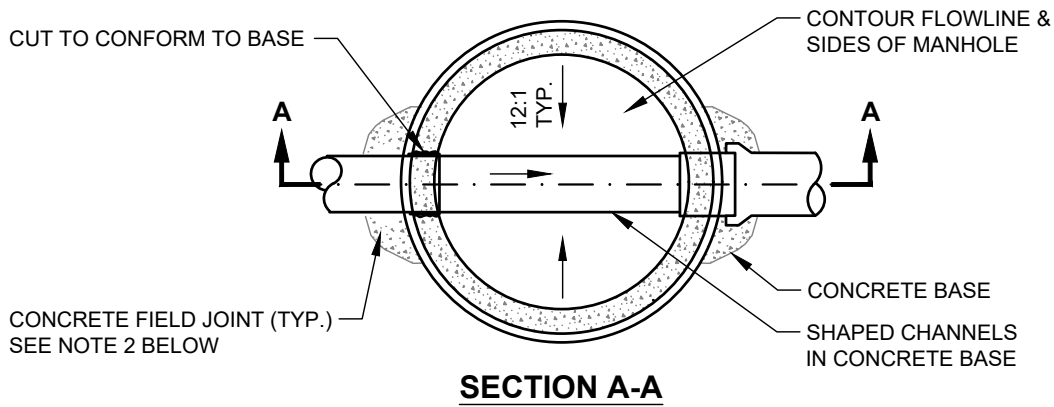

**NOTES:**

1. INSTALL NEOPRENE BOOT WITH STAINLESS STEEL BANDS & GROUT INSIDE OF MANHOLE FOR SANITARY SEWER PIPE CONNECTIONS. GROUT INSIDE & OUTSIDE PIPE CONNECTIONS FOR STORM DRAIN & OTHER DRAINAGE PIPES.
2. INSTALL 8" THICK CONCRETE FIELD JOINT AROUND ALL STORM DRAINAGE PIPES (TYP.). INSTALL AROUND ALL CONCRETE SEWER PIPES 18" DIA. & LARGER.
3. MANHOLE RING & COVER SHALL MATCH GRADE & CROSS SLOPE OF ROADWAY. ("TWIST", ROTATING OR ADJUSTABLE MANHOLE RING & COVER MAY BE REQUIRED).
4. LARGER MANHOLES MAY BE REQUIRED DEPENDING ON PIPE SIZINGS AND ORIENTATION WITHIN MANHOLE.
5. TOP OF MANHOLE COVER SHALL BE SET TO FINAL GRADE PRIOR TO PAVING. CONCRETE COLLARS MAY BE ALLOWED, BUT ONLY AFTER PRIOR APPROVAL OF LEHI CITY STREET DEPARTMENT. IF APPROVED, CONCRETE COLLARS SHALL BE 12" MIN. WIDE (FROM EDGE OF MANHOLE RING) AND 12" MIN. THICKNESS.
6. IN NON-PAVED AREAS, A 12" THICK BY 12" WIDE (FROM EDGE OF MANHOLE RING) CONCRETE COLLAR SHALL BE PROVIDED FLUSH WITH THE TOP OF THE MANHOLE COVER.



LEHI CITY STANDARD DETAIL

**LINE MANHOLE  
(SEWER & STORM DRAIN)**

**SD-01**

DATE:  
JANUARY 2022

CONTOUR FLOWLINE &  
SIDES OF MANHOLE

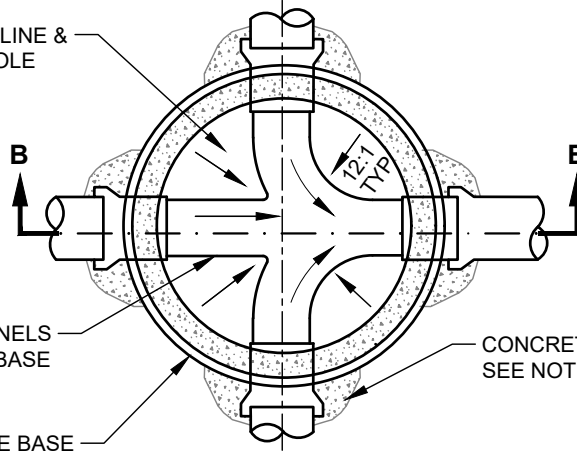

SHAPED CHANNELS  
IN CONCRETE BASE

CONCRETE BASE

CONCRETE FIELD JOINT (TYP.)  
SEE NOTE 2 BELOW

### SECTION B-B

INSTALL 1/4" TO 1/2" LOWER THAN ASPHALT SURFACE  
(SEE ALSO NOTES 3, 5 & 6 BELOW)

30" MANHOLE RING, FRAME AND COVER  
MARKED "SEWER" OR "STORM DRAIN"

FINISHED GRADE

GRADE RINGS AS REQ'D (12" MAX.)

GROUT GRADE RING INTO PLACE (TYP.)

MANHOLE STEPS (COPOLYMER POLYPROPYLENE PLASTIC)  
INSTALLATION OF STEPS SHALL BE WATERPROOF.

GROUT ALL JOINTS ON PRECAST  
CONCRETE SECTION

PRECAST CONCRETE MANHOLE SECTION  
GROUT IN CONCRETE BASE

ALL JOINTS SHALL BE WATERPROOFED

CUT PIPE BEFORE PLACING  
IN CONCRETE BASE

4' DIA. MANHOLE  
5' DIA. MANHOLE OF  
15" AND LARGER PIPE  
(SEE NOTE 4 BELOW)

6" MAX

MANHOLE  
FLOOR

18"

B

B

CONCRETE BASE 9" MIN. THICKNESS  
REQ'D UNDER PIPE

CONCRETE FIELD JOINT (TYP.)  
SEE NOTE 2 BELOW

FOUNDATION TO REST ON FIRM UNDISTURBED  
SOIL ON 6" MIN. DEPTH OF 1" MAX. GRADED  
ROCK WHEN DIRECTED BY CITY ENGINEER

PIPE / MANHOLE CONNECTION (TYP.)  
(SEE NOTE 1 BELOW)

#### NOTES:

1. INSTALL NEOPRENE BOOT WITH STAINLESS STEEL BANDS & GROUT INSIDE OF MANHOLE FOR SANITARY SEWER PIPE CONNECTIONS. GROUT INSIDE & OUTSIDE PIPE CONNECTIONS FOR STORM DRAIN & OTHER DRAINAGE PIPES.
2. INSTALL 8" THICK CONCRETE FIELD JOINT AROUND ALL STORM DRAINAGE PIPES (TYP.). INSTALL AROUND ALL CONCRETE SEWER PIPES 18" DIA. & LARGER.
3. MANHOLE RING & COVER SHALL MATCH GRADE & CROSS SLOPE OF ROADWAY. ("TWIST", ROTATING OR ADJUSTABLE MANHOLE RING & COVER MAY BE REQUIRED).
4. LARGER MANHOLES MAY BE REQUIRED DEPENDING ON PIPE SIZINGS AND ORIENTATION WITHIN MANHOLE.
5. TOP OF MANHOLE COVER SHALL BE SET TO FINAL GRADE PRIOR TO PAVING. CONCRETE COLLARS MAY BE ALLOWED, BUT ONLY AFTER PRIOR APPROVAL OF LEHI CITY STREET DEPARTMENT. IF APPROVED, CONCRETE COLLARS SHALL BE 12" MIN. WIDE (FROM EDGE OF MANHOLE RING) AND 12" MIN. THICKNESS.
6. IN NON-PAVED AREAS, A 12" THICK BY 12" WIDE (FROM EDGE OF MANHOLE RING) CONCRETE COLLAR SHALL BE PROVIDED FLUSH WITH THE TOP OF THE MANHOLE COVER.



LEHI CITY STANDARD DETAIL

**JUNCTION MANHOLE  
(SEWER & STORM DRAIN)**

**SD-02**

DATE:  
JANUARY 2022

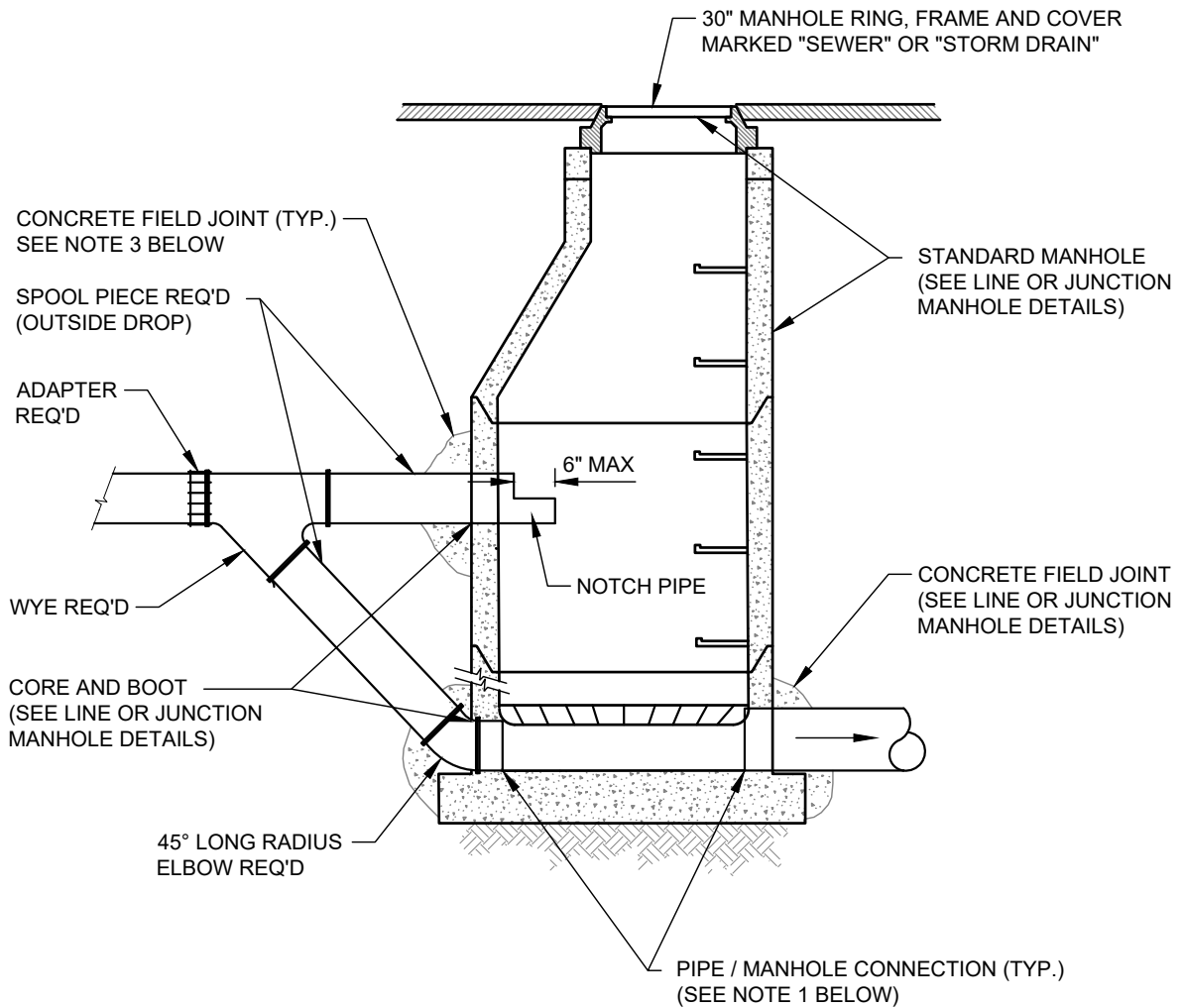

NOTES:

1. DROP MANHOLES MAY BE REQUIRED FOR PIPES ENTERING 24" OR MORE ABOVE THE INVERT OF THE MANHOLE. EXTERNAL DROP MANHOLES MAY BE USED ONLY AS APPROVED BY WATER AND WASTEWATER SUPERINTENDENT.
2. LATERAL SHALL NOT ENTER MANHOLES UNLESS OTHERWISE APPROVED BY CITY ENGINEER AND CITY PUBLIC WORKS DIRECTOR.
3. INSTALL 8" THICK CONCRETE FIELD JOINT AROUND PIPE (TYP.)



LEHI CITY STANDARD DETAIL	
<b>EXTERNAL DROP MANHOLE (SEWER &amp; STORM DRAIN)</b>	
<b>SD-03</b>	DATE: JANUARY 2022

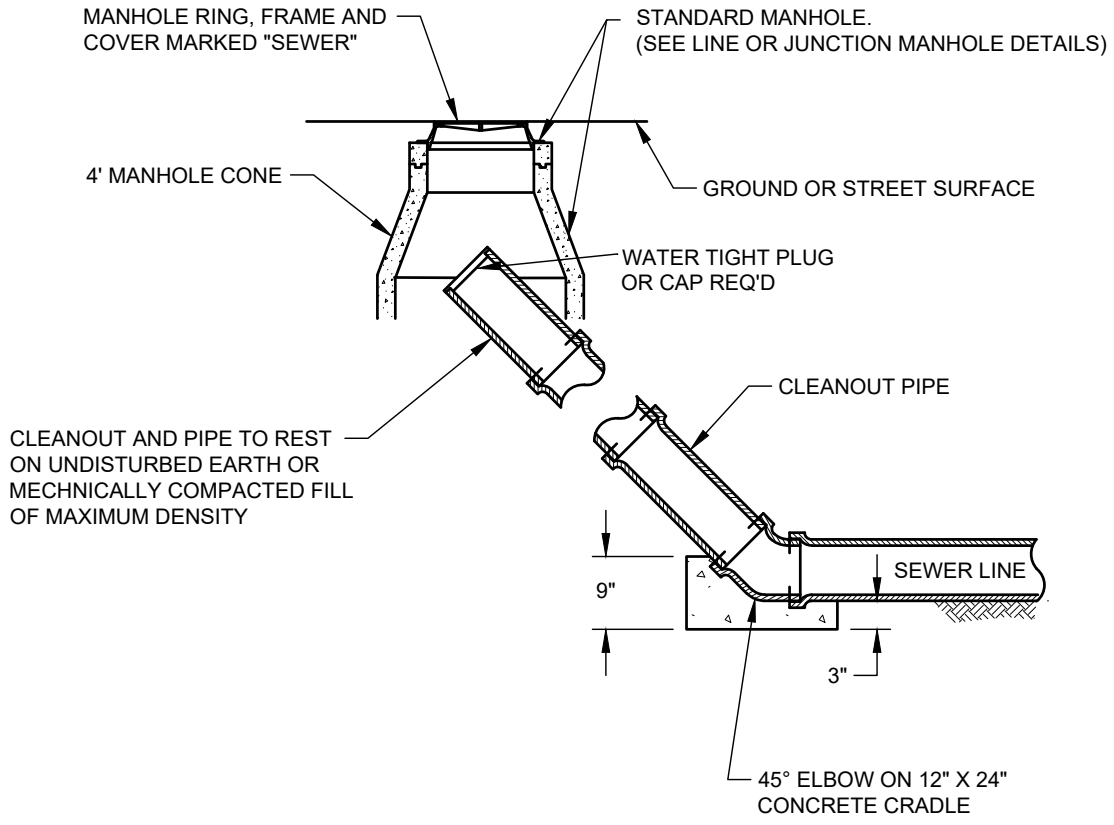

LEHI CITY STANDARD DETAIL

**TEMPORARY SEWER  
MAIN CLEANOUT**

**SD-04**

DATE:  
JANUARY 2022

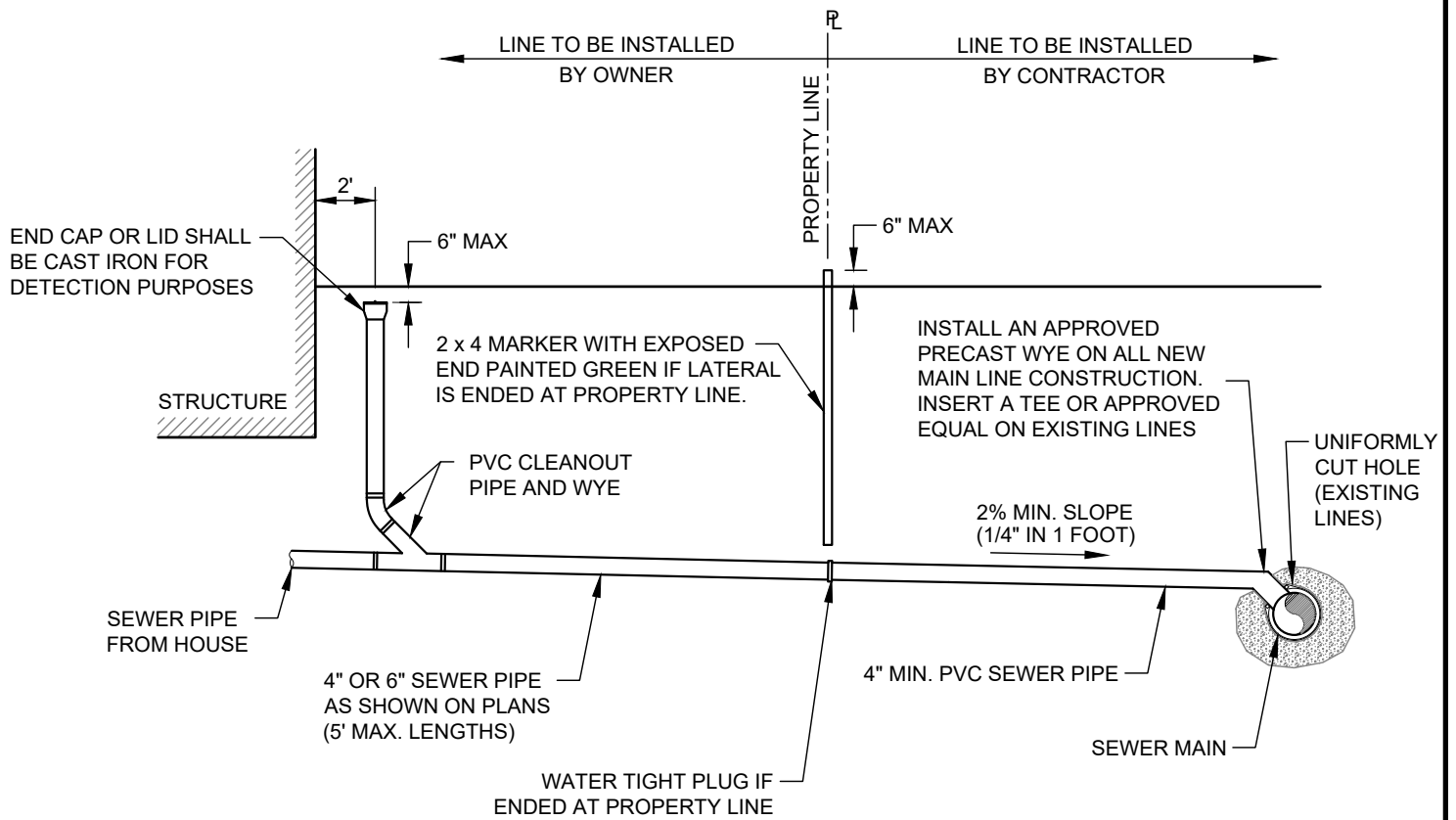

NOTES:

1. MAXIMUM DISTANCE BETWEEN CLEANOUTS: 100 FEET
2. LATERALS SHALL NOT ENTER MANHOLES UNLESS OTHERWISE APPROVED BY CITY ENGINEER



LEHI CITY STANDARD DETAIL

**SEWER LATERAL**

**SD-05**

DATE:  
JANUARY 2022

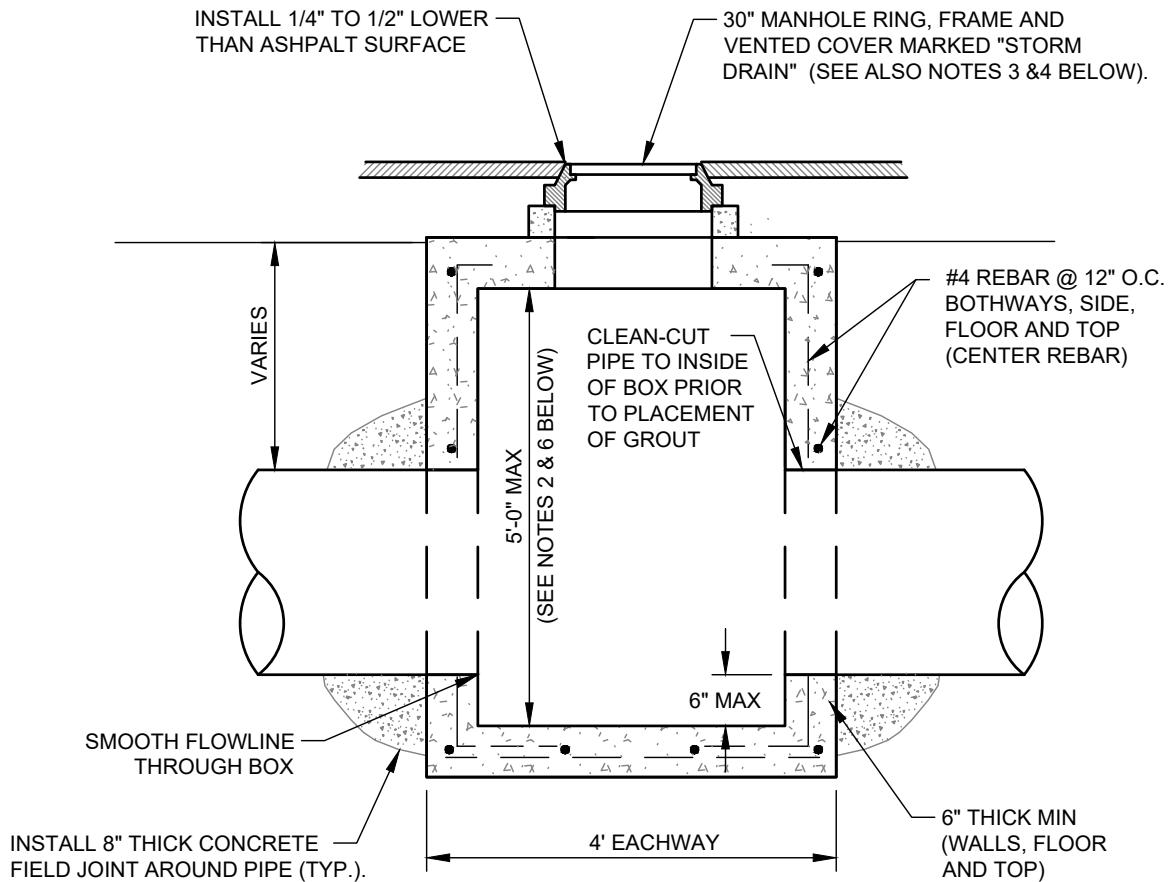

NOTES:

1. AN ENGINEERED PRECAST BOX MAY BE ALLOWED AS APPROVED BY THE CITY
2. FOR DEPTHS NOT TO EXCEED 5', OTHERWISE USE STANDARD LINE OR JUNCTION MANHOLE
3. MANHOLE RING & COVER SHALL MATCH GRADE & CROSS SLOPE OF ROADWAY. (TWIST, ROTATING OR ADJUSTABLE MANHOLE RING & COVER MAY BE REQUIRED).
4. VENTED RING, COVER & BOX SHALL BE CAPABLE OF SUPPORTING TRAFFIC LOADS. RING & COVER MAY BE SUBSTITUTED WITH A GRATED LID WHEN OUTSIDE OF PAVED ROADWAY AREAS (AS APPROVED BY THE CITY ENGINEER OR PUBLIC WORKS DIRECTOR), BUT SHALL ALSO BE CAPABLE OF SUPPORTING TRAFFIC LOADS.
5. 3'X3' I.D. CLEANOUT BOX MAY BE REQUIRED IF MORE THAN ONE PIPE ENTERS / EXITS BOX.
6. BMP "SNOOT" MAY BE REQUIRED WITHIN STORM DRAINAGE BOXES TO MEET STORM WATER QUALITY REQUIREMENT. CLEAN OUT BOX DEPTH SHALL BE MODIFIED TO MEET "SNOOT" MANUFACTURER'S GUIDELINES. ORIFICE PLATES SHOULD NOT BE INSTALLED BEHIND "SNOOT" HOODS.



LEHI CITY STANDARD DETAIL

**DRAIN CLEAN-OUT BOX**

**SD-06**

DATE:  
JANUARY 2022

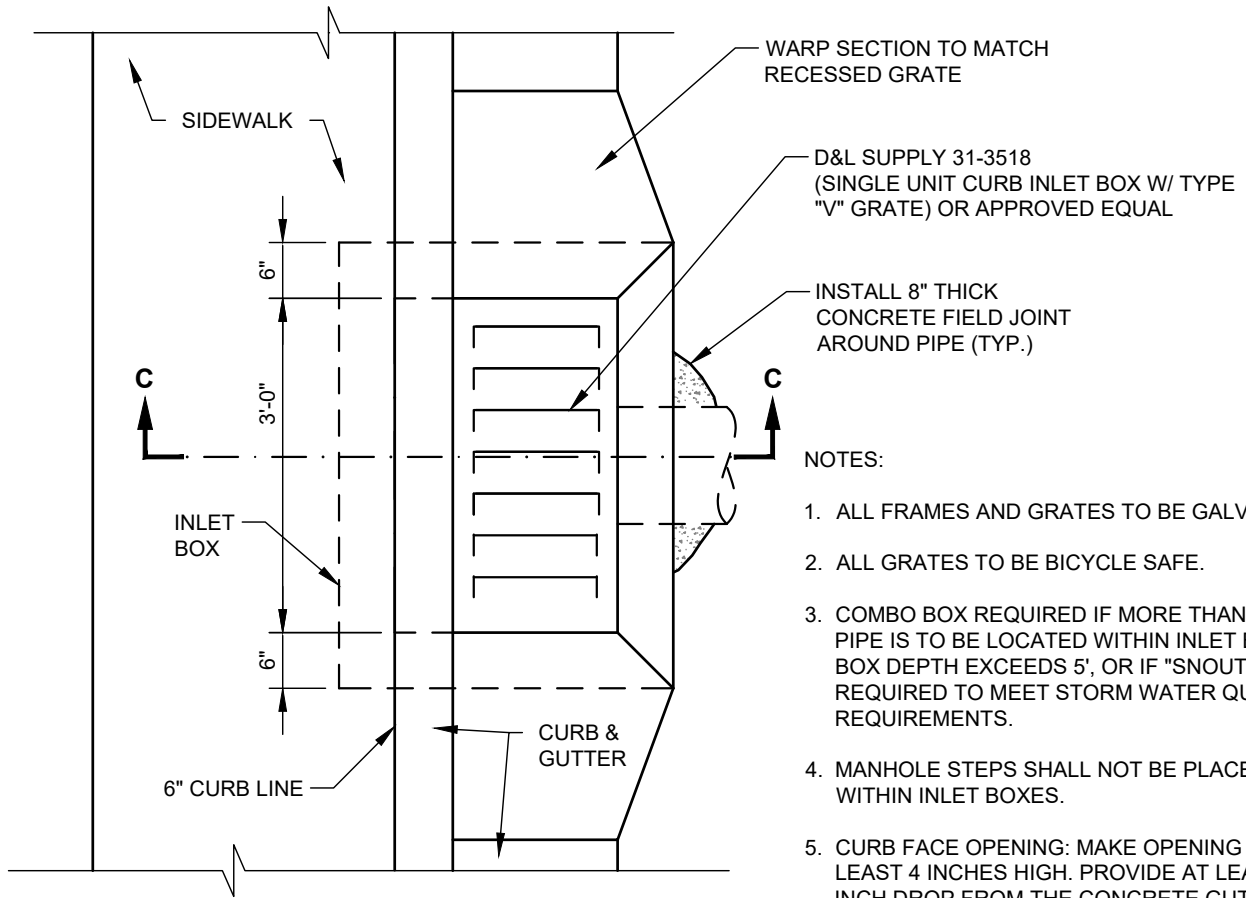

**PLAN VIEW**

**NOTES:**

1. ALL FRAMES AND GRATES TO BE GALVANIZED.
2. ALL GRATES TO BE BICYCLE SAFE.
3. COMBO BOX REQUIRED IF MORE THAN ONE PIPE IS TO BE LOCATED WITHIN INLET BOX, BOX DEPTH EXCEEDS 5', OR IF "SNOUTS" ARE REQUIRED TO MEET STORM WATER QUALITY REQUIREMENTS.
4. MANHOLE STEPS SHALL NOT BE PLACED WITHIN INLET BOXES.
5. CURB FACE OPENING: MAKE OPENING AT LEAST 4 INCHES HIGH. PROVIDE AT LEAST A 2 INCH DROP FROM THE CONCRETE GUTTER FLOWLINE TO THE TOP OF THE GRATE AT THE CURB FACE OPENING.

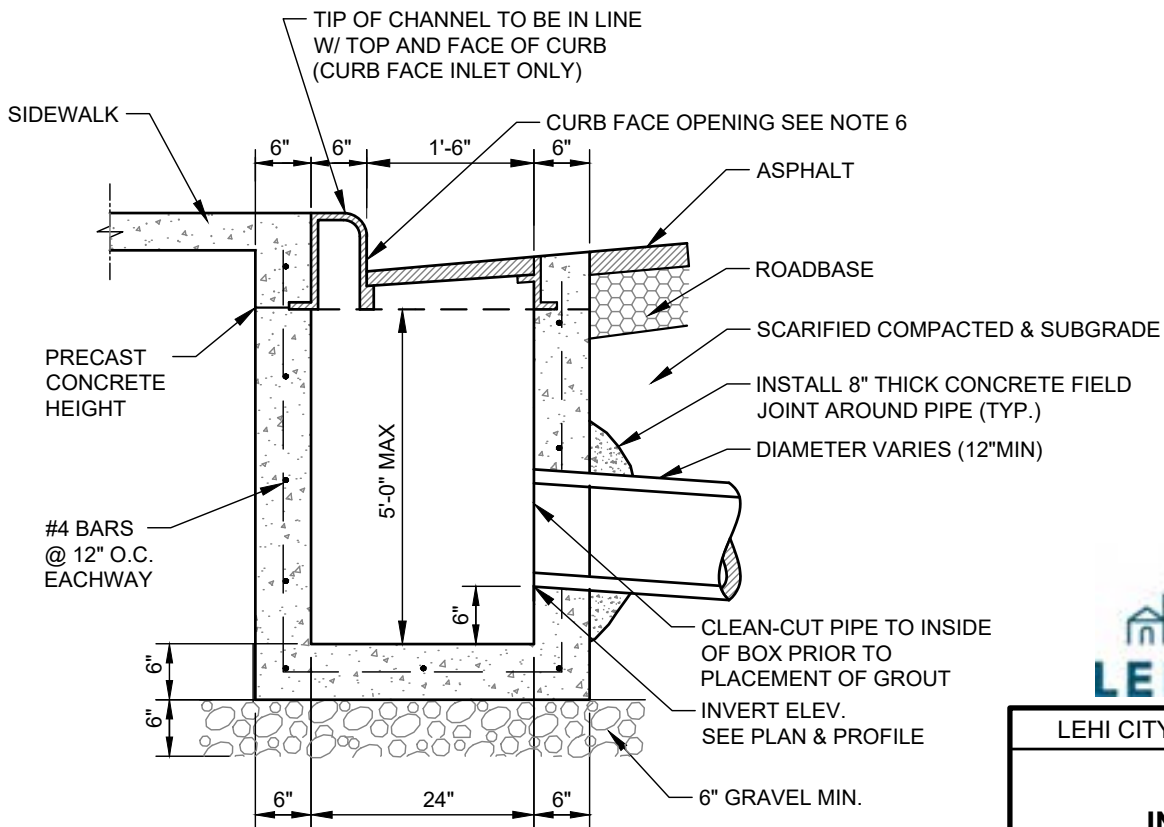

**SECTION C**



LEHI CITY STANDARD DETAIL

**INLET BOX**

**SD-07**

DATE:  
JANUARY 2022

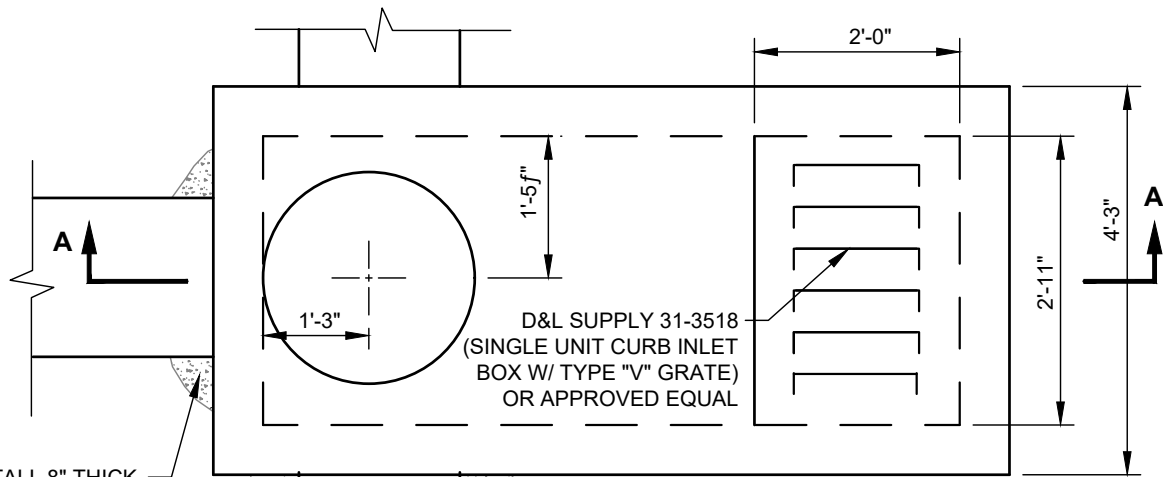

**PLAN VIEW**

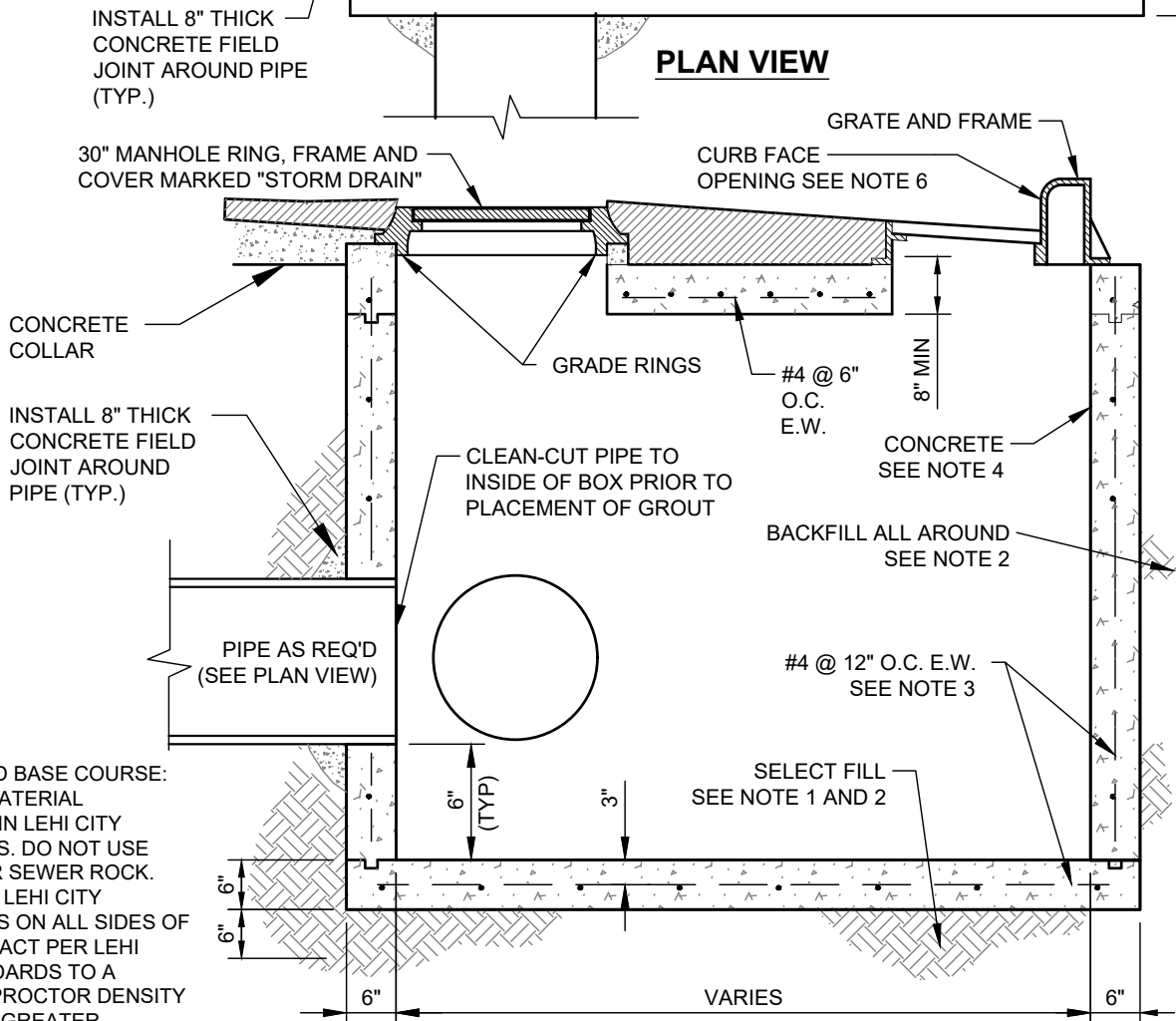

**SECTION A-A**

**NOTES:**

1. UNTREATED BASE COURSE: PROVIDE MATERIAL SPECIFIED IN LEHI CITY STANDARDS. DO NOT USE GRAVEL OR SEWER ROCK. PLACE PER LEHI CITY STANDARDS ON ALL SIDES OF BOX. COMPACT PER LEHI CITY STANDARDS TO A MODIFIED PROCTOR DENSITY OF 95% OR GREATER. MAXIMUM LIFT THICKNESS IS 8" BEFORE COMPACTION.
2. BACKFILL: PROVIDE AND PLACE PER LEHI CITY STANDARDS ON ALL SIDES OF BOX. COMPACT PER LEHI CITY STANDARDS TO A MODIFIED PROCTOR DENSITY OF 95% OR GREATER. MAXIMUM LIFT THICKNESS IS 8" BEFORE COMPACTION.
3. REINFORCEMENT: ASTM A 615, GRADE 60, DEFORMED STEEL. SEE LEHI CITY STANDARDS.
4. CONCRETE: CLASS 4000 PER LEHI CITY STANDARDS. PLACE PER LEHI CITY STANDARDS. CURE PER LEHI CITY STANDARDS.
5. MANHOLE STEPS: PROVIDE COPOLYMER POLYPROPYLENE PLASTIC COATED MANHOLE STEPS IN BOXES OVER FOUR FEET DEEP. PLACE BOTTOM STEP SIX INCHES ABOVE BOTTOM OF FLOOR. INSTALLATION OF STEPS SHALL BE WATERPROOFED.
6. CURB FACE OPENING: MAKE OPENING AT LEAST 4 INCHES HIGH. PROVIDE AT LEAST A 2 INCH DROP FROM THE CONCRETE GUTTER FLOWLINE TO THE TOP OF THE GRATE AT THE CURB FACE OPENING.
7. BMP "SNOUT" MAY BE REQUIRED WITHIN STORM DRAINAGE BOXES TO MEET STORM WATER QUALITY REQUIREMENTS. COMBO BOX DEPTH SHALL BE MODIFIED TO MEET "SNOUT" MANUFACTURER'S GUIDELINES. ORIFICE PLATES SHOULD NOT BE INSTALLED BEHIND "SNOUT" HOODS.



LEHI CITY STANDARD DETAIL

**COMBO BOX**

**SD-08**

DATE:  
JANUARY 2022

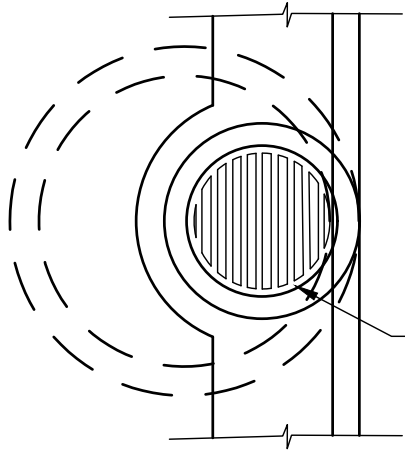

BICYCLE SAFE DROP INLET.  
GRATE AND FRAME TO BE GALVANIZED

**PLAN**

INSTALL 8" THICK CONCRETE FIELD JOINT AROUND PIPE (TYP.)

12" STORM DRAIN PIPE FROM CATCH BASIN ON OPPOSITE SIDE CURB AND GUTTER (OPTIONAL)

CLEAN-CUT PIPE TO INSIDE OF BOX PRIOR TO PLACEMENT OF GROUT

1 1/2" DIA DRAIN HOLE 12" O.C.

6" CONCRETE

5'-0" INSIDE DIA.

OVERFLOW TO DRAINAGE APPROVED BY CITY ENGINEER, IF REQUIRED

3'-0" ECCENTRIC CONE

WALL SECTIONS DEPTH VARIES

1" GRAVEL AND COBBLE DRAIN MATERIAL. 2' SURROUNDING OUTSIDE OF LOWER SECTIONS AND UNDER BOTTOM

INSTALL SEPARATION FABRIC. LAP ALL SEAMS A MIN. OF 12"

**SECTION**

**NOTE:**

- 1. ALTERNATIVE SUMP DESIGNS MAY BE REQUIRED DEPENDING ON GROUND WATER TABLE.



LEHI CITY STANDARD DETAIL

**STORM WATER SUMP**

**SD-09**

DATE: JANUARY 2022

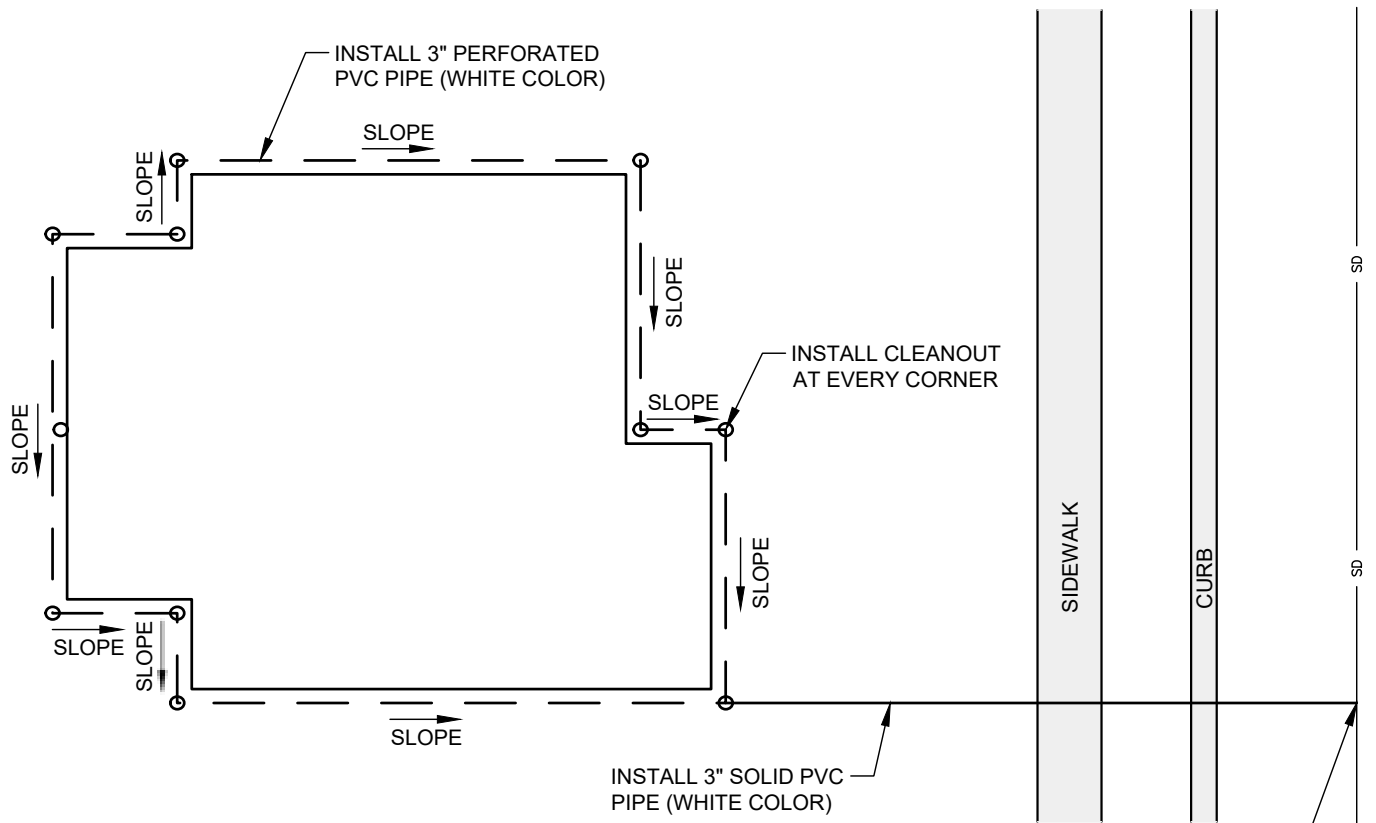

**PLAN**

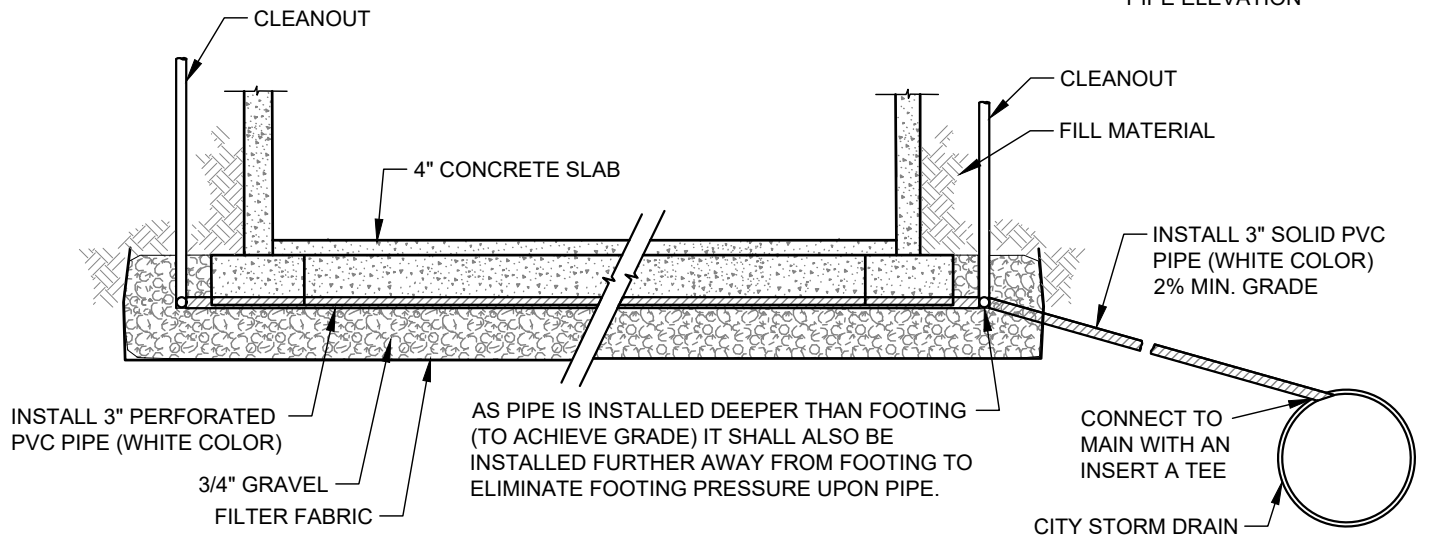

**SECTION**

**NOTE:**

1. SUBSURFACE DRAIN FIGURES SHOWN ABOVE ARE FOR REFERENCE ONLY. A SITE-SPECIFIC GEOTECHNICAL REPORT SHALL BE SUBMITTED SHOWING THE DEPTHS, SIZES, AND LOCATIONS OF ALL PROPOSED SUBSURFACE DRAINAGE PIPING.

NOTE: ONLY ALLOWED AS AUTHORIZED OR DIRECTED BY THE STORM WATER SUPERINTENDENT AND BUILDING OFFICIAL



LEHI CITY STANDARD DETAIL	
<b>BUILDING SUBSURFACE DRAINS</b>	
<b>SD-10</b>	DATE: JANUARY 2022

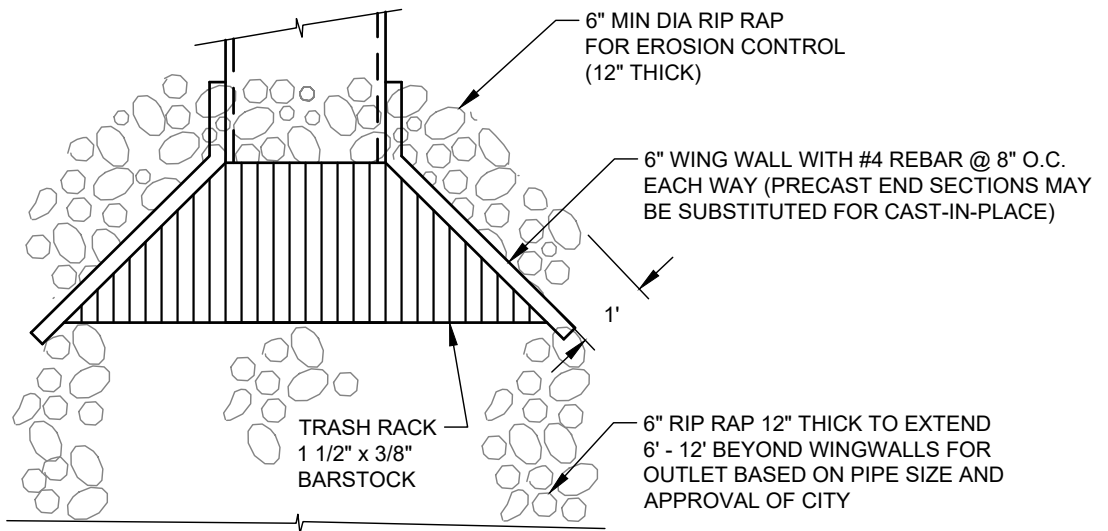

**PLAN VIEW**

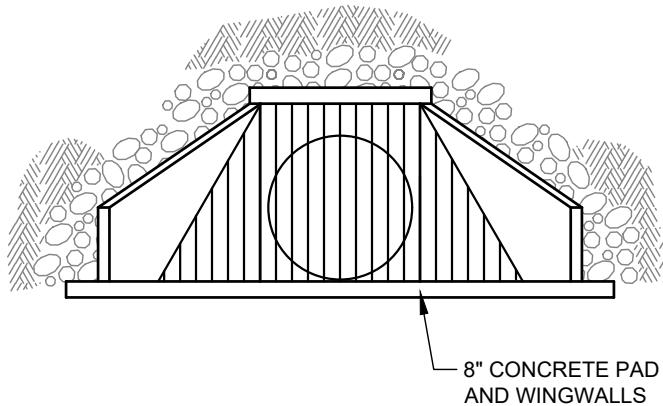

**FRONT VIEW**

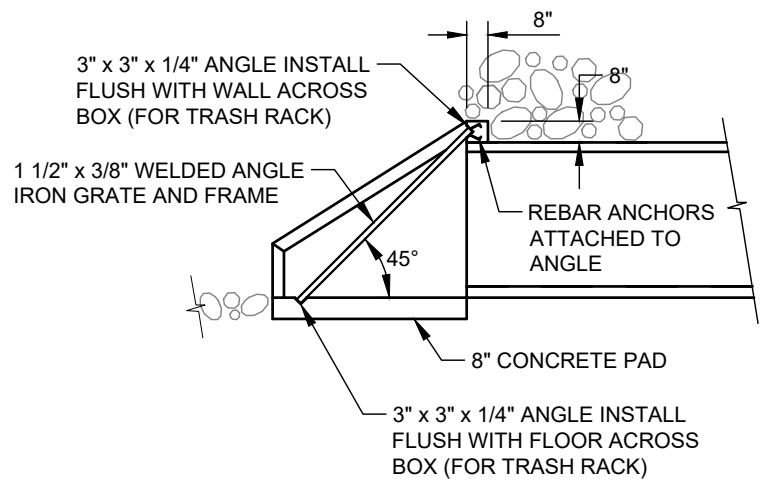

**SECTION VIEW**

**NOTES:**

1. USE TRASH RACK FOR INLETS ONLY, NOT REQUIRED ON OUTLETS.
2. OPENING BETWEEN THE BARS SHALL NOT EXCEED 2".
3. HYDRAULIC DESIGN CALCULATIONS MAY BE REQUIRED FOR HEADWALL / RIP-RAP DESIGN APPROVALS.
4. HEADWALL, GRATING, RIP-RAP SIZING AND FLOW CALCULATIONS MUST BE APPROVED BY LEHI CITY ENGINEER PRIOR TO CONSTRUCTION.



LEHI CITY STANDARD DETAIL

**HEADWALL DETAIL**

**SD-11**

DATE:  
JANUARY 2022

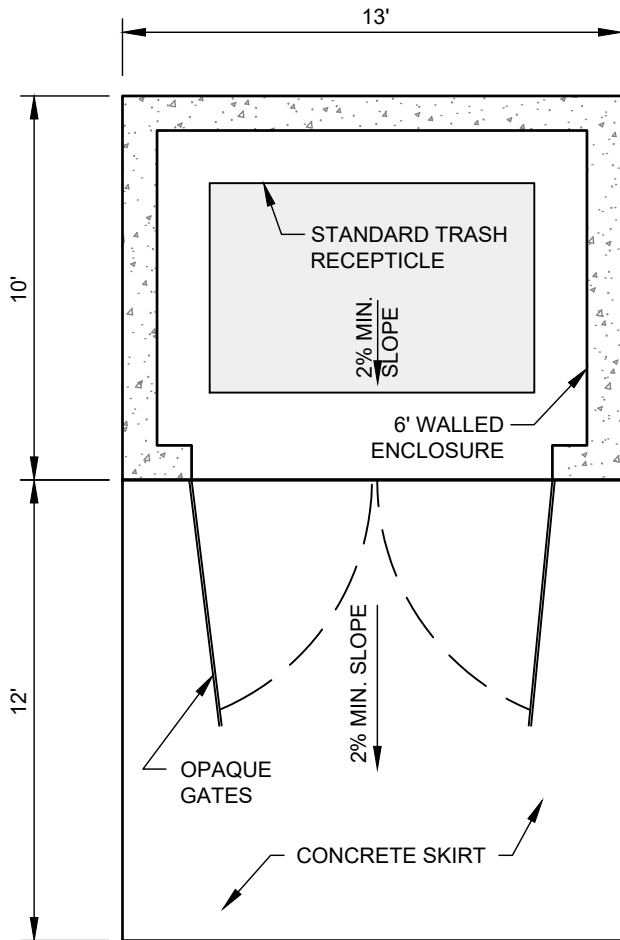

**DUMPSTER**

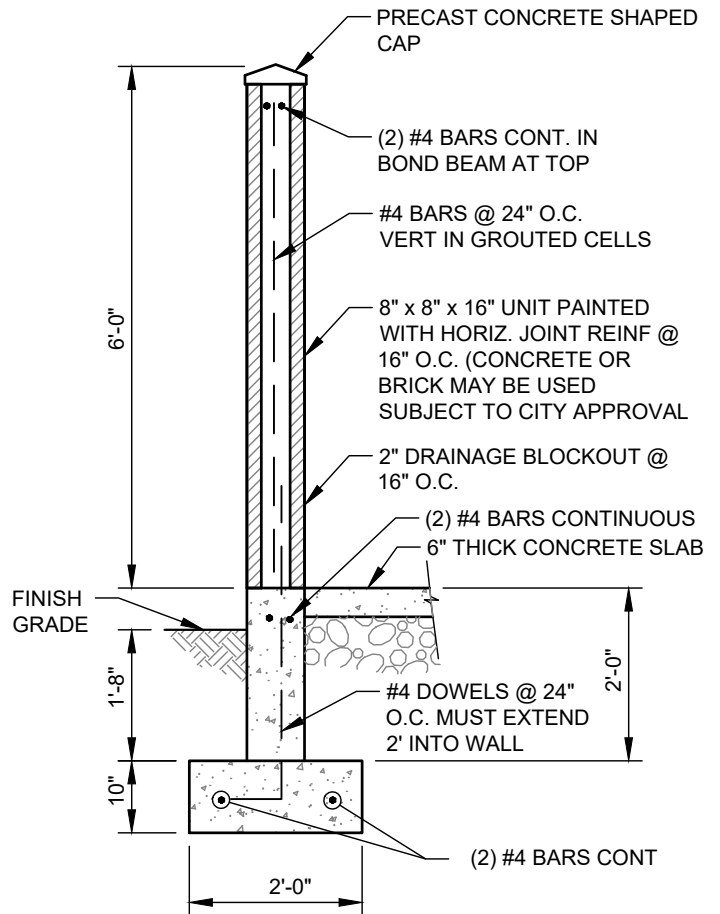

**TRASH ENCLOSURE WALL DETAIL**

**NOTES**

ALTERNATE DESIGNS MAY BE USED AS APPROVED BY THE BUILDING OFFICIAL



LEHI CITY STANDARD DETAIL

**TRASH ENCLOSURE**

**TE-01**

DATE:  
JANUARY 2022

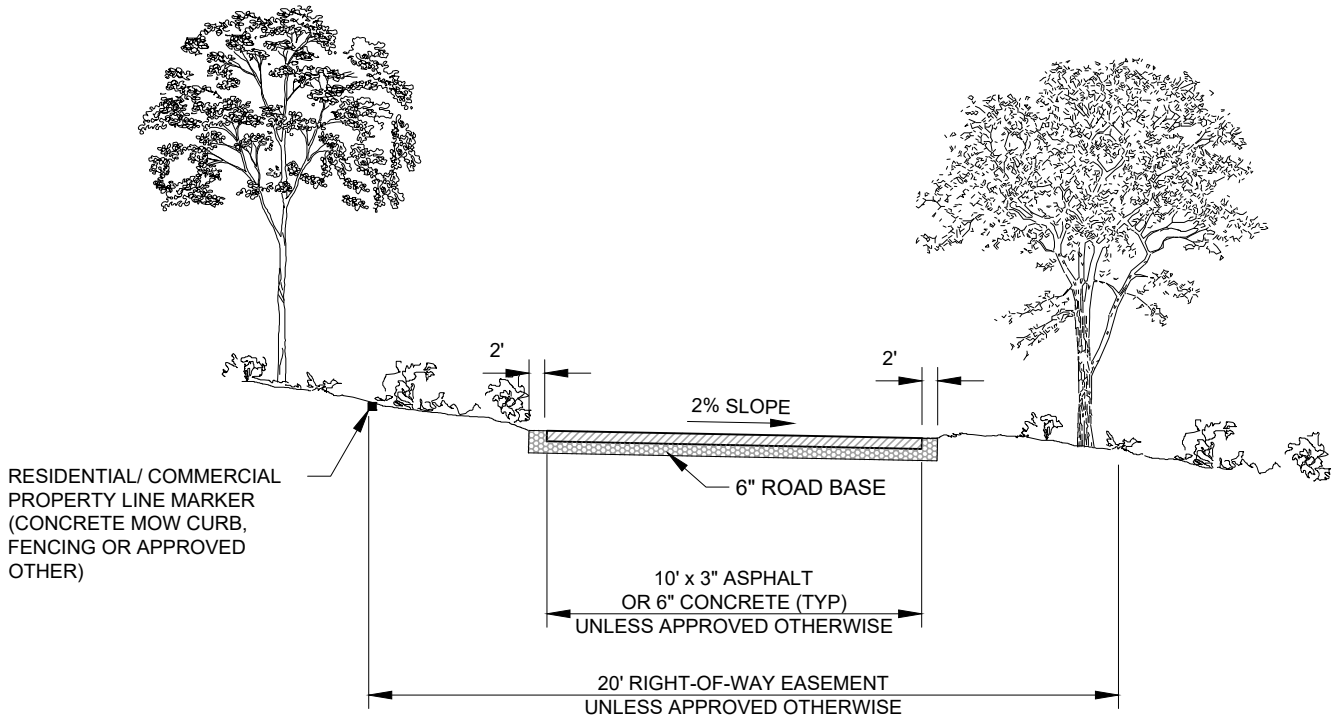

**NOTES:**

1. CROSS SECTION MAY BE ADJUSTED DEPENDING ON EXISTING CONSTRAINTS AS APPROVED BY THE LEHI CITY ENGINEER.
2. 2' COMPACTED SHOULDER MUST SLOPE AT A 6:1 MAX SLOPE ON EACH SIDE OF THE PAVED TRAIL.
3. SLOPE TRAIL 2% TO AVOID PONDING. PROVIDE DRAINAGE IMPROVEMENTS ALONG TRAIL AS REQUIRED TO CONVEY POSSIBLE STORM FLOWS.
4. CONTRACTOR SHALL REMOVE ALL FOLIAGE, ROOTS AND WASTE MATERIALS WITHIN A 12" ZONE BENEATH BASE COURSE. 12" ZONE SHALL THEN BE COMPACTED PRIOR TO THE PLACEMENT OF ROAD BASE COURSE. CONTRACTOR SHALL ALSO PLACE GROUND STERILANT PRIOR TO PLACEMENT OF ROAD BASE.
5. ALL PEDESTRIAN TRAIL DESIGN PLANS SHALL BE REVIEWED AND APPROVED BY LEHI CITY STAFF PRIOR TO CONSTRUCTION.
6. ADA AND PEDESTRIAN RAMPS SHALL BE CONCRETE AND MATCH THE WIDTH OF THE TRAIL.
7. DETECTABLE WARNING SURFACES SHALL EXTEND (24 IN) MINIMUM IN THE DIRECTION OF TRAVEL AND THE FULL WIDTH OF THE CURB RAMP (EXCLUSIVE OF FLARES), THE LANDING, OR THE BLENDED TRANSITION.



LEHI CITY STANDARD DETAIL	
<b>BICYCLE / PEDESTRIAN SHARED USE TRAIL</b>	
<b>TR-01</b>	DATE: MAY 2024

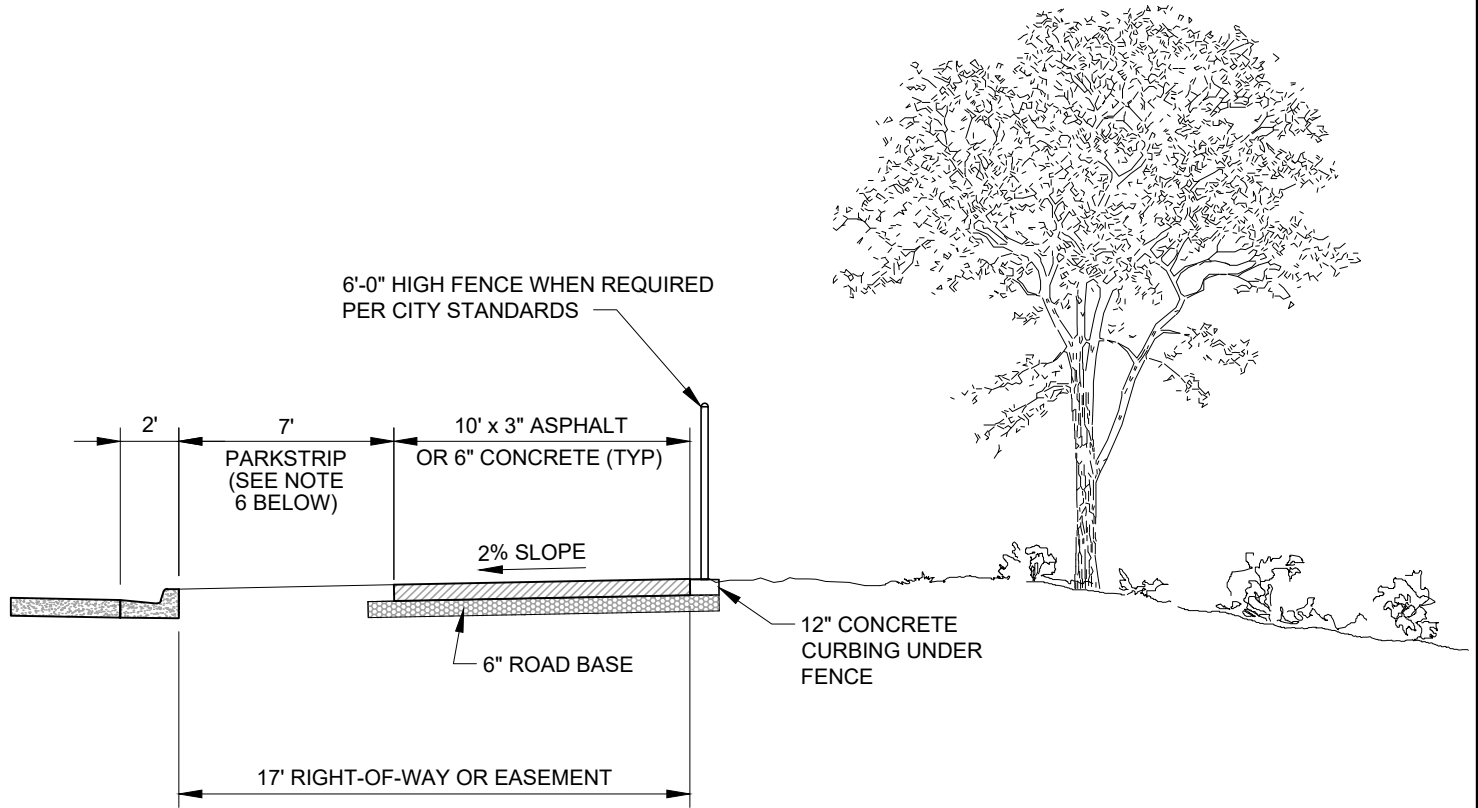

NOTES:

1. CROSS SECTION MAY BE ADJUSTED DEPENDING ON EXISTING CONSTRAINTS AS APPROVED BY THE LEHI CITY ENGINEER.
2. 2' COMPACTED SHOULDER MUST SLOPE AT A 6:1 MAX SLOPE ON EACH SIDE OF THE PAVED TRAIL.
3. SLOPE TRAIL 2% TO AVOID PONDING. PROVIDE DRAINAGE IMPROVEMENTS ALONG TRAIL AS REQUIRED TO CONVEY POSSIBLE STORM FLOWS.
4. CONTRACTOR SHALL REMOVE ALL FOLIAGE, ROOTS AND WASTE MATERIALS WITHIN A 12" ZONE BENEATH BASE COURSE. 12" ZONE SHALL THEN BE COMPACTED PRIOR TO THE PLACEMENT OF ROAD BASE COURSE. CONTRACTOR SHALL ALSO PLACE GROUND STERILANT PRIOR TO PLACEMENT OF ROAD BASE.
5. ALL PEDESTRIAN TRAIL DESIGN PLANS SHALL BE REVIEWED AND APPROVED BY LEHI CITY STAFF PRIOR TO CONSTRUCTION.
6. SEE SECTION 2 OF WRITTEN STANDARDS FOR GUIDELINES REGARDING RECOMMENDED PARK STRIP TREATMENTS.
7. WHERE APPLICABLE GATES WILL BE REQUIRED FOR UTILITY ACCESS.



LEHI CITY STANDARD DETAIL

**BICYCLE / PEDESTRIAN  
SHARED USE TRAIL ALONG  
ARTERIAL ROAD**

**TR-02**

DATE:  
MAY 2024

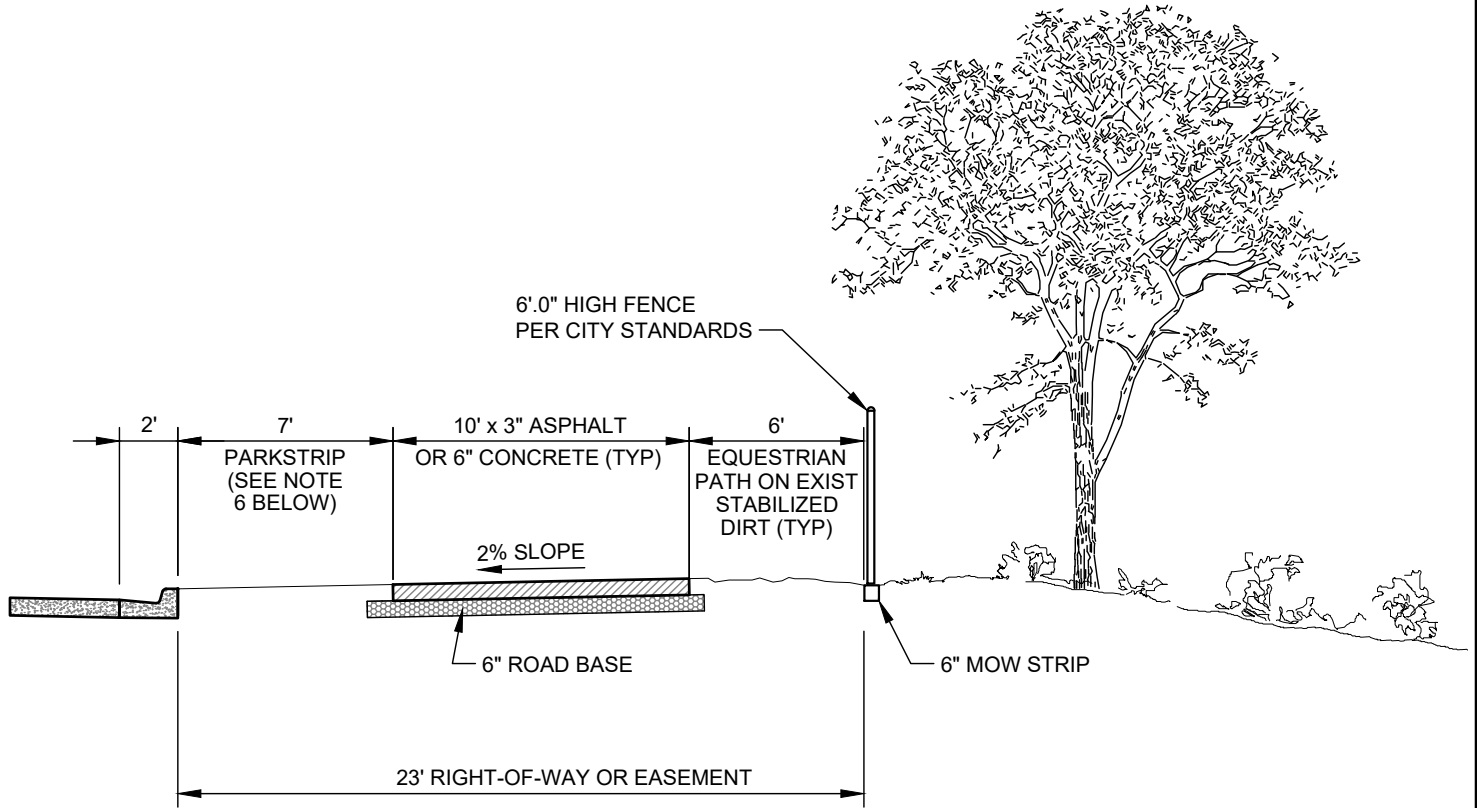

NOTES:

1. CROSS SECTION MAY BE ADJUSTED DEPENDING ON EXISTING CONSTRAINTS AS APPROVED BY THE LEHI CITY ENGINEER.
2. 2' COMPACTED SHOULDER MUST SLOPE AT A 6:1 MAX SLOPE ON EACH SIDE OF THE PAVED TRAIL.
3. SLOPE TRAIL 2% TO AVOID PONDING. PROVIDE DRAINAGE IMPROVEMENTS ALONG TRAIL AS REQUIRED TO CONVEY POSSIBLE STORM FLOWS.
4. CONTRACTOR SHALL REMOVE ALL FOLIAGE, ROOTS AND WASTE MATERIALS WITHIN A 12" ZONE BENEATH BASE COURSE. 12" ZONE SHALL THEN BE COMPACTED PRIOR TO THE PLACEMENT OF ROAD BASE COURSE. CONTRACTOR SHALL ALSO PLACE GROUND STERILANT PRIOR TO PLACEMENT OF ROAD BASE.
5. ALL PEDESTRIAN TRAIL DESIGN PLANS SHALL BE REVIEWED AND APPROVED BY LEHI CITY STAFF PRIOR TO CONSTRUCTION.
6. SEE SECTION 2 OF WRITTEN STANDARDS FOR GUIDELINES REGARDING RECOMMENDED PARK STRIP TREATMENTS.



LEHI CITY STANDARD DETAIL

**BICYCLE / PEDESTRIAN & EQUESTRIAN SHARED USE TRAIL ALONG ARTERIAL ROAD**

**TR-03**

DATE:  
JANUARY 2022